

Hardware Kit (289-440KDP46)

NO.	Q.TY	DESCRIPTION
A	4 PCS.	K.D.SCREW (LONG)
B	3 PCS.	K.D.SCREW (SHORT)
C	11 PCS.	FLAT WASHER
D	11 PCS.	LOCK WASHER
E	4 PCS.	NUT
F	4 PCS.	WOOD SCREW
G	1 PC.	KEY WRENCH

Parts Key

289-440KDP40	CHAIR BACK
289-440KDP41	COMPLETE SEAT
289-440KDP42	RIGHT FACING LEG
289-440KDP43	LEFT FACING LEG
289-440KDP44	SIDE STRETCHER

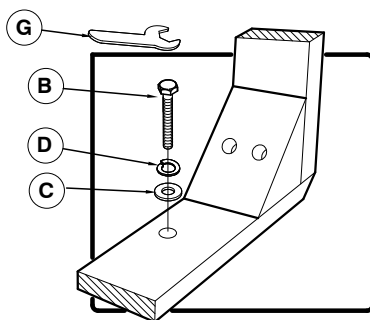
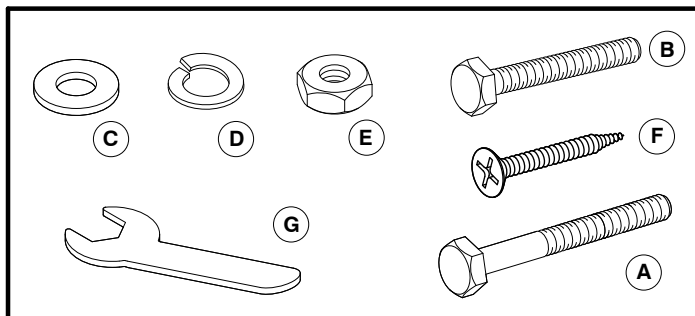

DETAIL A

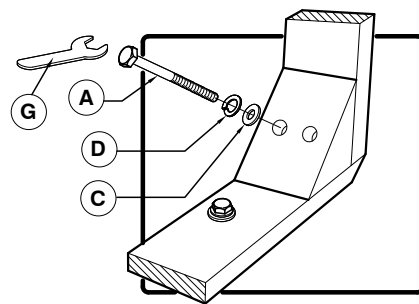

DETAIL B

STEP : 1

- REMOVE ALL PARTS FROM CARTON.
- OPEN CARTON SO THAT IT CAN BE USED AS WORK SURFACE FOR ASSEMBLY.
- PLACE THE CHAIR BACK ON THE CARTON.
- PLACE THE WOOD SEAT ON THE CHAIR BACK AND INSERT A FLAT WASHER (C), LOCK WASHER (D) AND A SHORT K.D.SCREW (B) INTO EACH OF THE 3 HOLES ON BACK OF THE SEAT TIGHTEN THE SCREW WITH THE KEY WRENCH (G) BY TURNING CLOCKWISE UNTIL SECURE. (SEE DETAIL : A)
- INSERT THE FLAT WASHER (C), LOCK WASHER (D) AND LONG K.D.SCREW (A) INTO EACH OF 2 HOLES IN THE SEAT CORNERS. TIGHTEN THE SCREWS WITH THE KEY WRENCH (G). (SEE DETAIL : B)

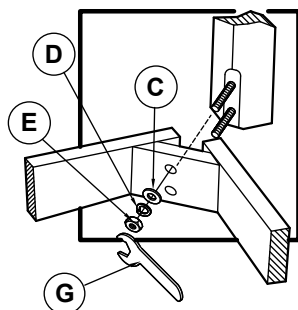
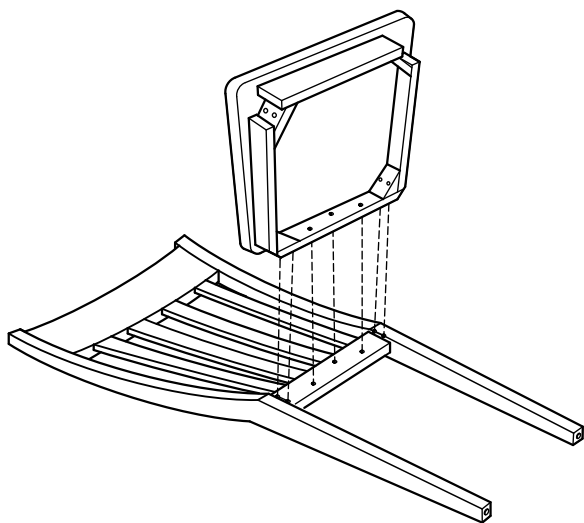

DETAIL C

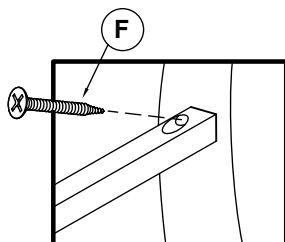

DETAIL D

STEP 2

- TURN OVER THE CHAIR AND ATTACH THE LEGS TO THE FRONT OF THE CORNER SEAT FRAME.
- PLACE FLAT WASHER (C), LOCK WASHER (D) AND NUT (E) ON EACH LEG.
- TURN THE NUT (E) ON EACH LEG SEVERAL TURNS WITH KEY WRENCH (G) BUT DO NOT TIGHTEN.
- INSERT 2 SIDE STRETCHERS INTO THE HOLES BETWEEN FRONT AND BACK LEG AND FASTEN WITH WOOD SCREW (F) ON EACH END WITH PHILLIPS HEAD SCREWDRIVER. (NOT PROVIDED)
- TIGHTEN ALL SCREWS BEFORE USING STOOL.

