



Features:

- Cast brass valves
- Ceramic disc valve cartridge
- Adjustable hot limit safety stop
- Pressure Balance cartridge maintains constant output temperature in response to changes in relative hot and cold supply pressures
- Multi-functional showerhead
- Available with Knob or Lever Handle

Pictured: 822/451 Shower Set with Lever Handle

Showerhead Maximum Flow Rate: 2.5 GPM (9.5L/min)

Kit Options	Handle Type	Product Number
Shower Set	Knob	822/450
Shower Set	Lever	822/451
PB Shower Valve Set	Knob	822/130
PB Shower Valve Set	Lever	822/131



Rough & Trim Options	Handle Type	Product Number
Shower Set Trim Only*	Knob	822/485
Shower Set Trim Only*	Lever	822/486
PB Shower Valve Set Trim Only**	Knob	822/535
PB Shower Valve Set Trim Only**	Lever	822/536
Shower Head Only		822/083
Rough Only		899/260/191



* Includes Pressure Balance Shower Valve Trim & Shower Head

**Pressure Balance Shower Valve Trim Only

Available Finishes:	Finish Code
Old Bronze	105
Gold	109
Brushed Nickel	144
Platinum Nickel	150
Antique Nickel	444

Handle Options:

ROUGH-IN DIAGRAM SHOWN ON REVERSE SIDE

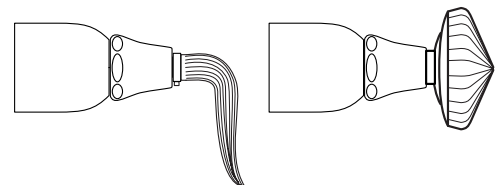

Lever Handle

Knob Handle

CODES & STANDARDS

These products meet and exceed the following codes and standards:

ASME A112.18.1

CSA B125

ASSE1016

 Meets the American Disabilities Act Guidelines and **ANSI A117.1** Requirements for the physically challenged.

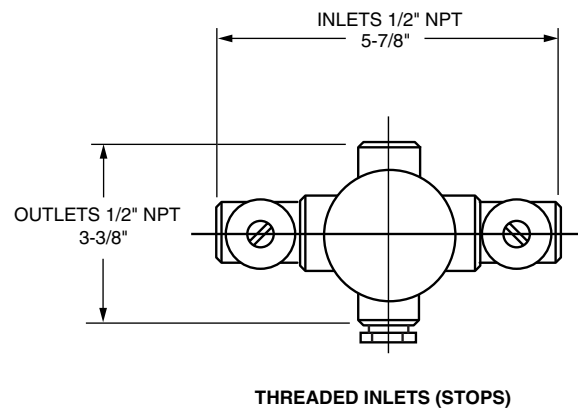
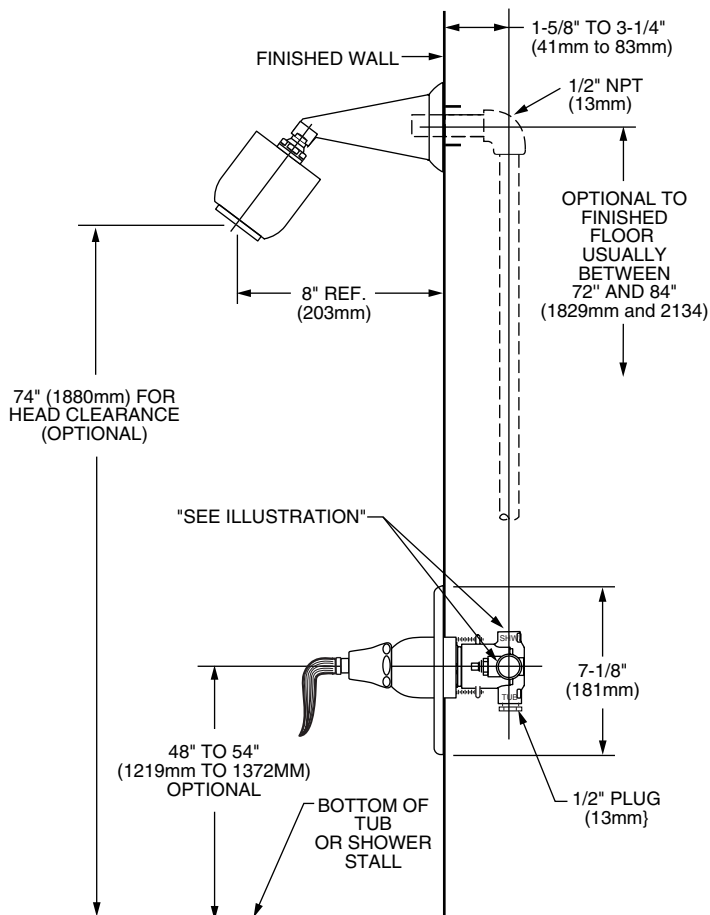
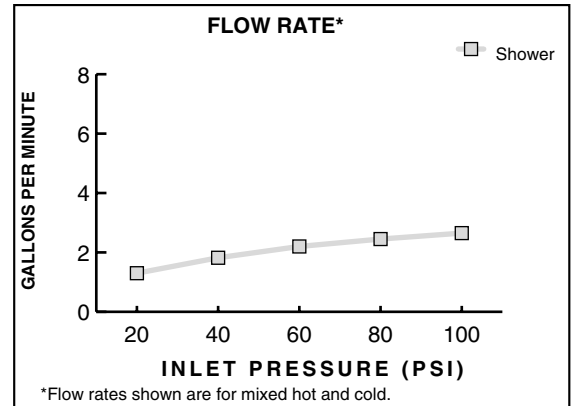

IMPORTANT: These measurements are subject to change or cancellation. No responsibility is assumed for use of superseded or voided pages.