

signa® 6 whirlpool bath and soaking bath

the signa® whirlpool bath takes its name from the medieval central Italian walled city, lastra a signa.



Like the walled city for which it is named, Signa® 6 was specially developed and designed for walled surround spaces.

features:

- 4 fully adjustable TheraPro™ jets
- 4 directionally adjustable AccuPro™ jets
- RapidHeat™ in-line heater
- Electronic on/off control
- Chromatherapy underwater lighting
- Contoured backrest
- Integral skirt with access panels on skirted models

signa® 6 whirlpool bath

model number: B460 – RH pump,
B540 – LH pump

exterior dimensions:
72" long x 42" wide x 22" high

interior dimensions (at bottom):
50" long x 24" wide

of Jets/type of Jets:
4 TheraPro™ Jets
4 AccuPro™ Back Jets

operating gallons:
55 gallons

signa® 6 soaking bath

model number: C100

exterior dimensions:
72" long x 42" wide x 22" high

interior dimensions:
50" long x 24" wide





Signa® 6 Whirlpool Bath

Model: B540, B460

Signa® 6 Bath

Model: C100

Ordering Information

Product Code:

B540 Signa® 6 Whirlpool Bath
Left Hand

B460 Signa® 6 Whirlpool Bath
Right Hand

C100 Signa® 6 Bath

- Center Drain Location
- Accessories / Hardware:
 - Trip-Lever Drain Kit #X559
 - Rotary Trip-Lever Drain Kit: #K606
 - 4 X HTC Jet Trim Kit: #D095
 - 2 X BMH Jet Trim Kit: #J869
- Trim Kit Finishes Available:
 - (827) - Chrome
 - (898) - Brushed Chrome
 - (815) - Satin Nickel
 - (829) - Bright Brass
 - (805) - Platinum
 - (826) - Brushed Nickel
 - (849) - Oil Rubbed Bronze

Installation Notes

Refer to installation instructions included with fixture before beginning installation. Please confirm product availability and specifications before commencing with any installation work.

PRODUCT SPECIFICATIONS AND AVAILABILITY ARE SUBJECT TO CHANGE WITHOUT NOTICE.

Electrical Components and Electrical Specifications do not apply to non-jetted baths.

Technical Specifications

Dimensions

72" L x 42" W x 22" H
(1829 mm) L x (1067 mm) W x (559 mm) H

Drain/Overflow

A: 16-7/8" (429 mm) B: 14" (356 mm)

Cutout

70" x 40"

Total Weight

B540, B460: 826 lb (375 kg) / 39 lb/sq. ft. (192 kg/m²)
C100: 781 lb (354 kg) / 37 lb/sq. ft. (180 kg/m²)

Operating Gallonage

55 U.S. Gal. (208 Liters)
Max. 103 U.S. Gal. (390 Liters)

Product Weight

B540, B460: 118 lb (54 kg)
C100: 73 lb (33 kg)

Skirt Mounting

Not Available

Electrical Specifications Models B540, B460 only

Requires a dedicated GFCI protected separate circuit.

Motor/Pump: 120 VAC, 15 AMP, 60 Hz.

RapidHeat™: 120 VAC, 15 AMP, 60 Hz.

Heater (Optional) Models B540, B460 only

Requires a dedicated GFCI protected separate circuit.

RapidHeat™: P/N S750000

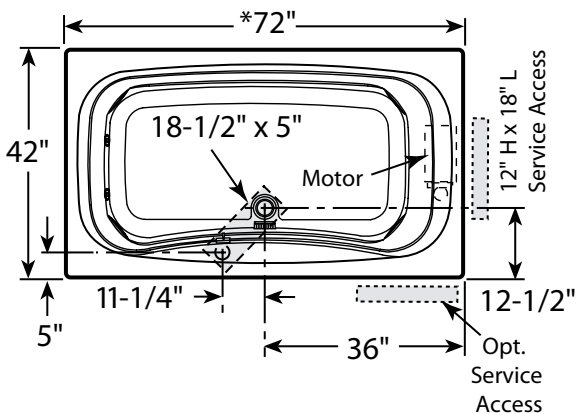

Product Shown: Signa® 6 Whirlpool Bath Right Hand Model: B460

* Measurements inside unit represent cutout in floor to allow for drain/overflow.

Minimum Service Access dimensions given.

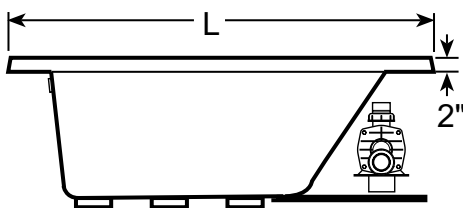

SIDE VIEW

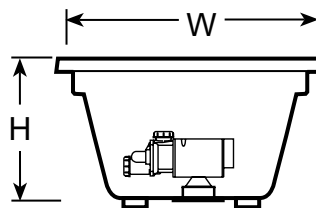

END VIEW

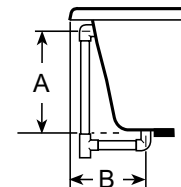

DRAIN/OVERFLOW