



MCH42 / MCH48

MODULAR SERIES

2400/3000

CORNER HUTCH

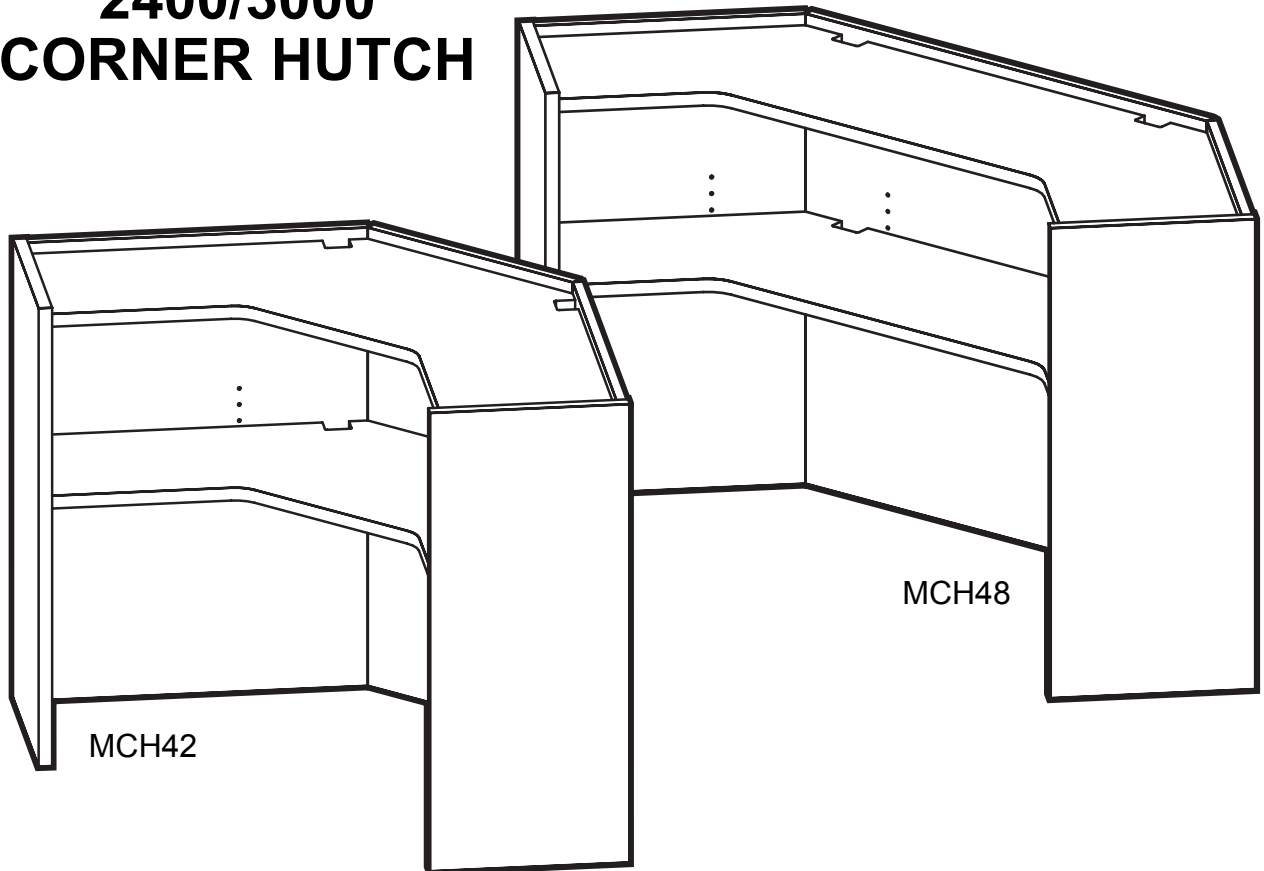

IMPORTANT!

Assembly may require the assistance of another person.

Before you begin assembly:

READ THE DIRECTIONS all the way through one time. This will speed up the process and help you understand the sequence of steps.

COUNT THE PARTS AND HARDWARE before assembly. This ensures you have received all necessary parts before you begin.

TOOLS: You may need a Phillips head screwdriver, a medium slotted screwdriver or a plastic mallet. To protect your new furniture from damage during assembly, it is recommended to work on a carpeted surface.

In the event any parts are missing from this package, send your name, address, telephone number, and a description of the missing part(s) to: PARTS, Box 1420, Missoula, MT 59806 or call: 1-800-769-5693 or FAX 1-800-445-5281.

CAUTION: On assemblies requiring glue, make sure the unit is assembled correctly before gluing. Once this unit is assembled with glue, the manufacturer will not be responsible for damaged parts. Keep a damp cloth or sponge handy to wipe off excess glue.

To care for this furniture, simply wipe with a cloth dampened with glass cleaner containing ammonia-D.

PARTS DIAGRAM

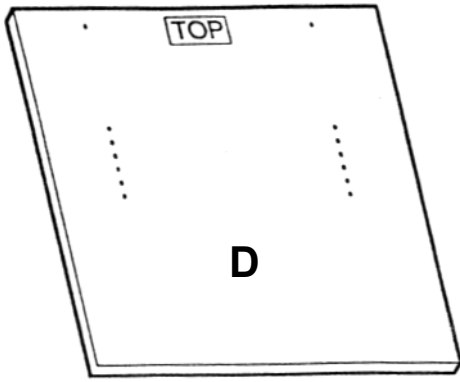

MCH48

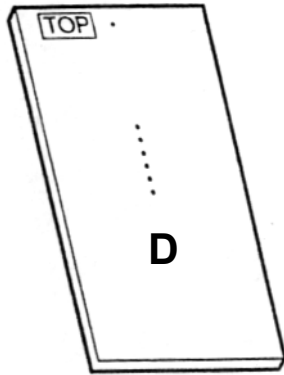

MCH42

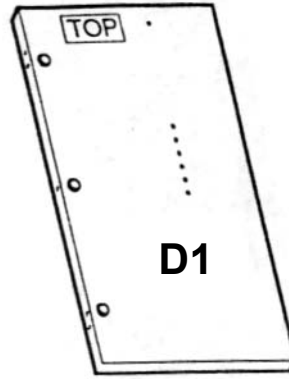

MCH48

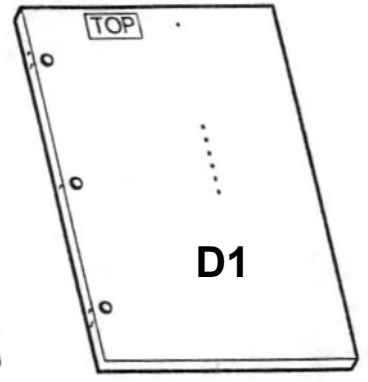

MCH42

Back Panel	MCH48	02340452	1 ea.
	MCH42	02340352	

Left Back Panel	MCH48	02340453	1 ea.
	MCH42	02340353	

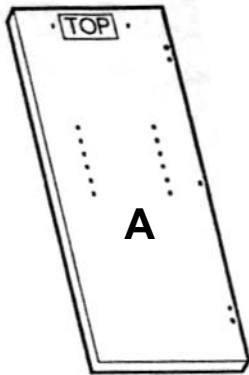

Left Side Panel	02340341	1 ea.
-----------------	----------	-------

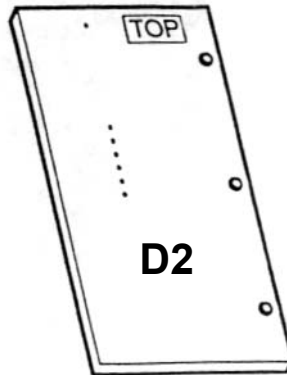

MCH48

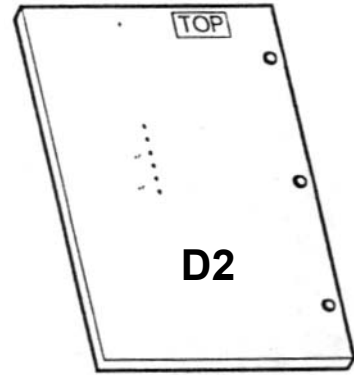

MCH42

Right Back Panel	MCH48	02340454	1 ea.
	MCH42	02340354	

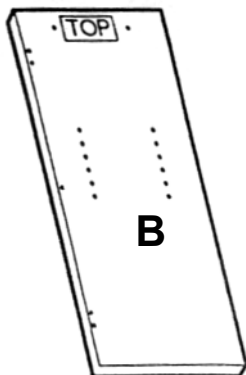

Right Side Panel	02340341	1 ea.
------------------	----------	-------

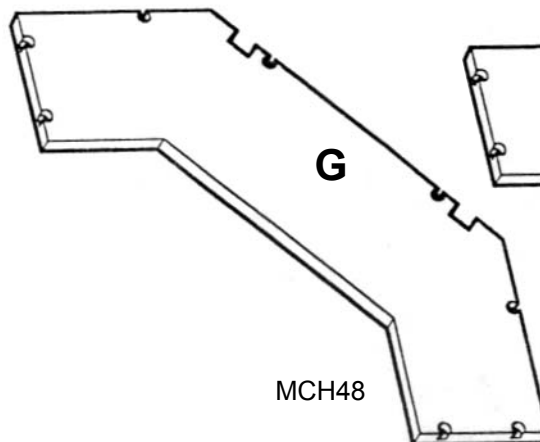

MCH48

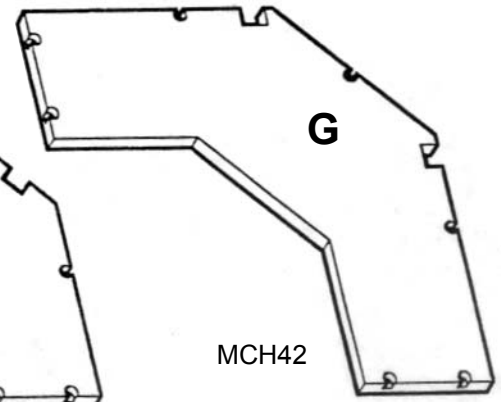

MCH42

Shelf	MCH48	02340424	2 ea.
	MCH42	02340324	

HARDWARE



H1	Rafix Cam	909910	MCH42 14 ea. MCH48 16 ea.
----	-----------	--------	------------------------------



H5	Rafix Bolt 8mm	909923	MCH42 14 ea. MCH48 16 ea.
----	-------------------	--------	------------------------------



H2	Minifix Bolt	909834	6 ea.
----	--------------	--------	-------

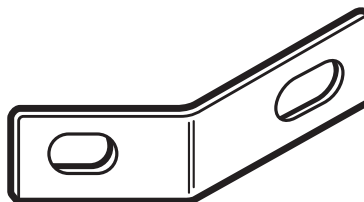

H6	Angle Bracket- MCH	401190	4 ea.
----	-----------------------	--------	-------



H3	Wood Dowel	195000	4 ea.
----	------------	--------	-------



H4	Minifix Cam	909810	6 ea.
----	-------------	--------	-------



H7	#10 x .625" Panhead Screw	901220	8 ea.
----	------------------------------	--------	-------

Using the Rafix System:

Insert the Rafix Cams into the appropriate holes. The flat edge of the cam should be facing the edge of the panel.

Slide Rafix Cams of the panel to be attached onto the corresponding posts.

When screwing post into hole, **Do Not** over tighten. Screw post down until bottom face of post flange just touches board surface.

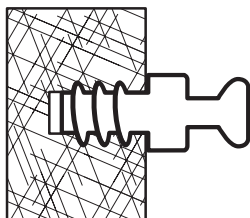

Using a #3 Phillips screwdriver, turn the rotating portion of the Rafix Cam a 1/2 turn clockwise to secure. **IMPORTANT!** Do not exceed 1/2 turn when tightening cams. Turn 1/2 turn counterclockwise to disassemble and remove panel.

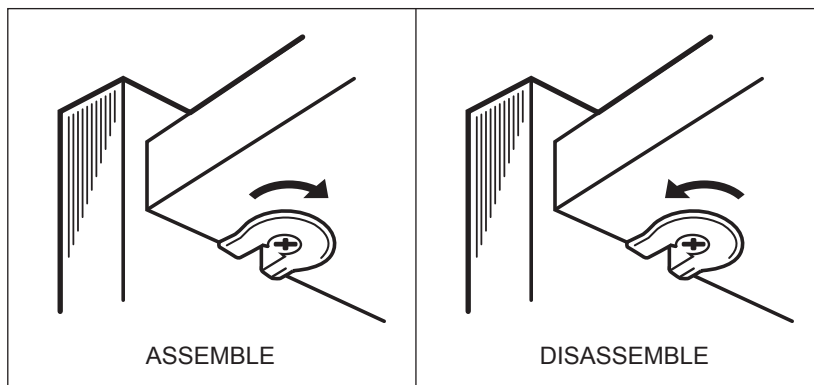
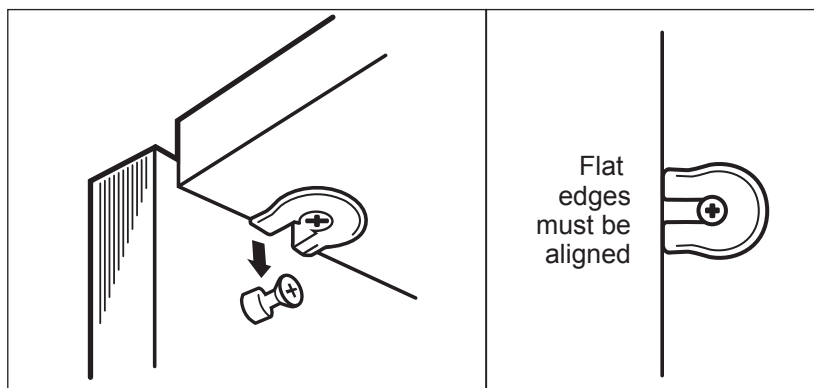

Using the Minifix System:

Insert the Minifix Cams into the appropriate holes with the arrow facing outwards as shown.

When screwing post into hole, **Do Not** over tighten. Screw post down until bottom face of post flange just touches board surface.

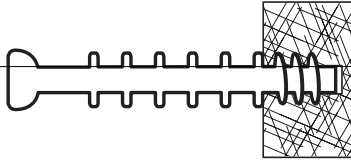
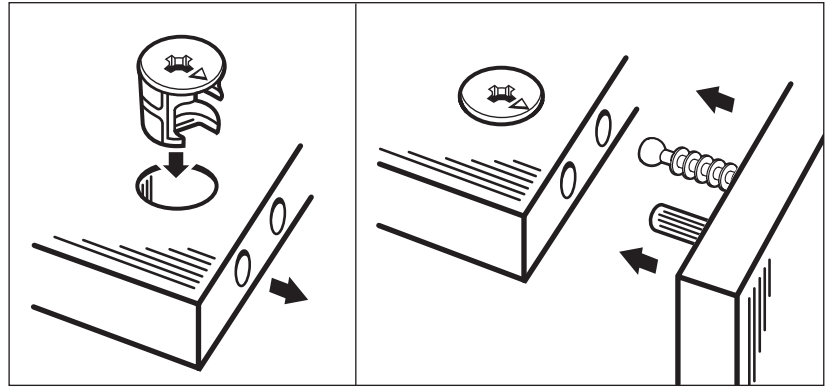

Using the #2 Phillips screwdriver, rotate the Cam Devices a half turn clockwise until snug.

To disassemble, turn the Cam Devices counter-clockwise and remove panels.

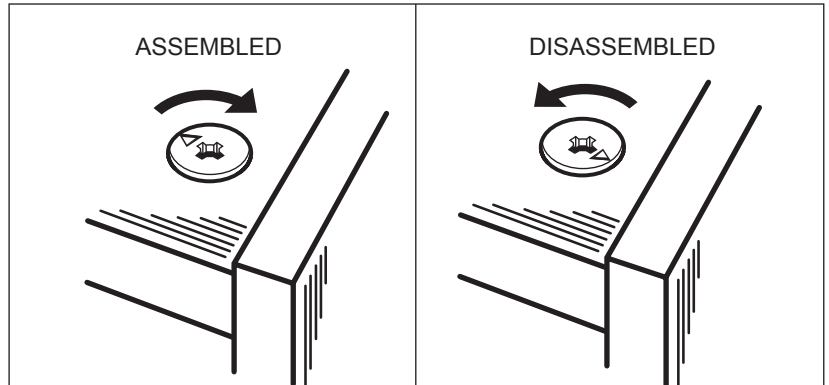

NOTE: Both the MCH42 and MCH48 Modular Corner Hitches assemble in a similar manner. For convenience, only the MCH48 is depicted in the following instructions.

#1

Place a Shelf (G) on a clean, carpeted surface as shown. Insert the Metal Rafix Cams (H1) into the Shelf with the flat edge facing outwards and tap until fully seated in place as shown. Insert Metal Rafix Cams into the other Shelf in the same manner.

Important! The flat edge of the Rafix Cam must be aligned with shelf edge. Rafix Cams can not be repositioned if installed incorrectly.

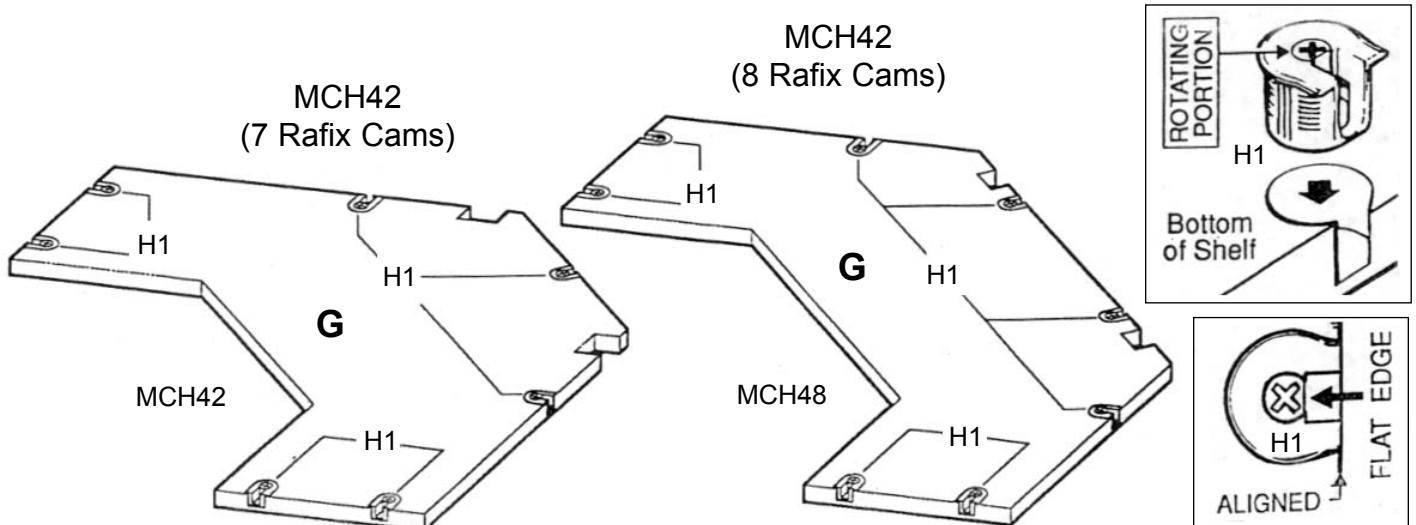

#2

Screw Minifix Bolts (H2) into the Left Side Panel (A) and the Right Side Panel (B) where indicated.

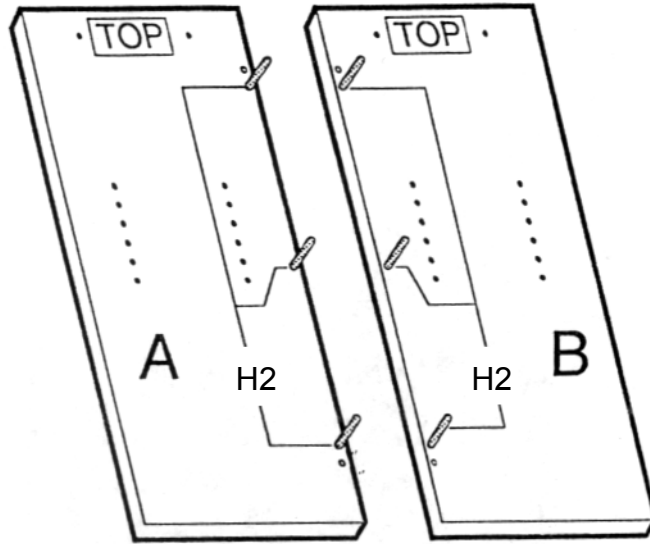
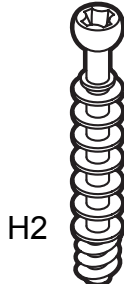

#3

Insert Wood Dowels (H3) into the Left Side Panel (A) and the Right Side Panel (B) where indicated.

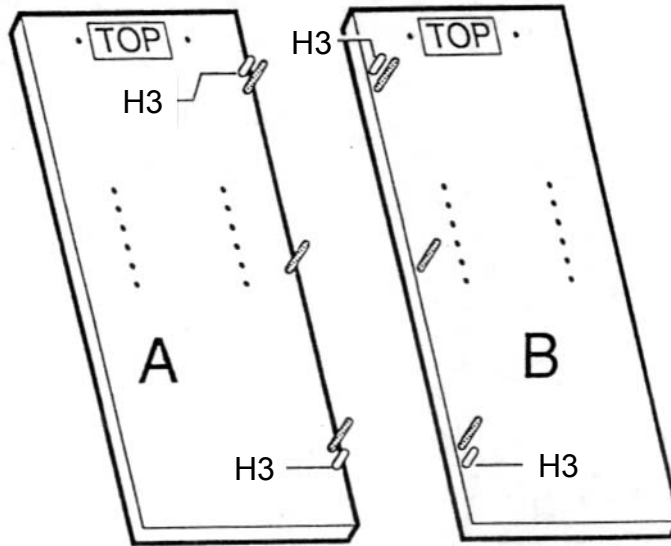

#4

Insert three Minifix Cams (H4) into the Left Back Panel (D1) and three Minifix Cams into the Right Back Panel (D2) with the arrows of the cams facing out.

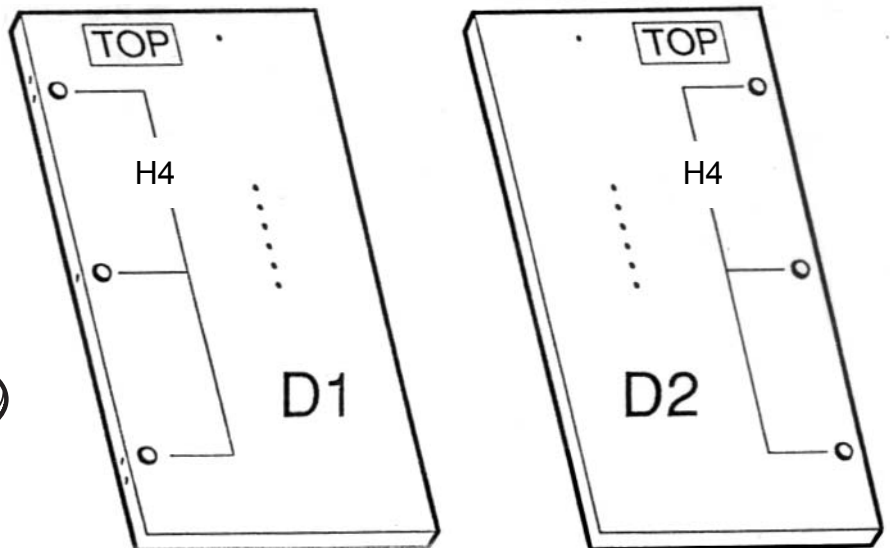

#5

Install Rafix Bolts (H5) into the upper holes of the Left Side Panel (A), Left Back Panel (D1), Back Panel (D), Right Back Panel (D2) and Right Side Panel (B) as indicated.



H5

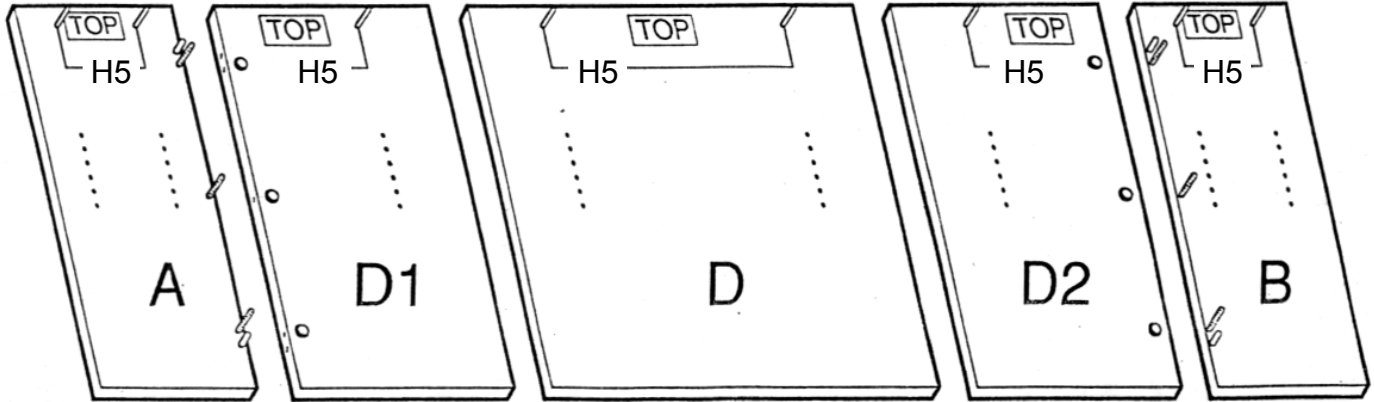

MCH42 = one Rafix Bolt
MCH48 = two Rafix Bolts

#6

Select the preferred height for the Self (G). Install Rafix Bolts (H5) into the appropriate set of pre-drilled holes of the Left Side Panel (A), Left Back Panel (D1), Back Panel (D), Right Back Panel (D2) and Right Side panel (B) as indicated.



H5

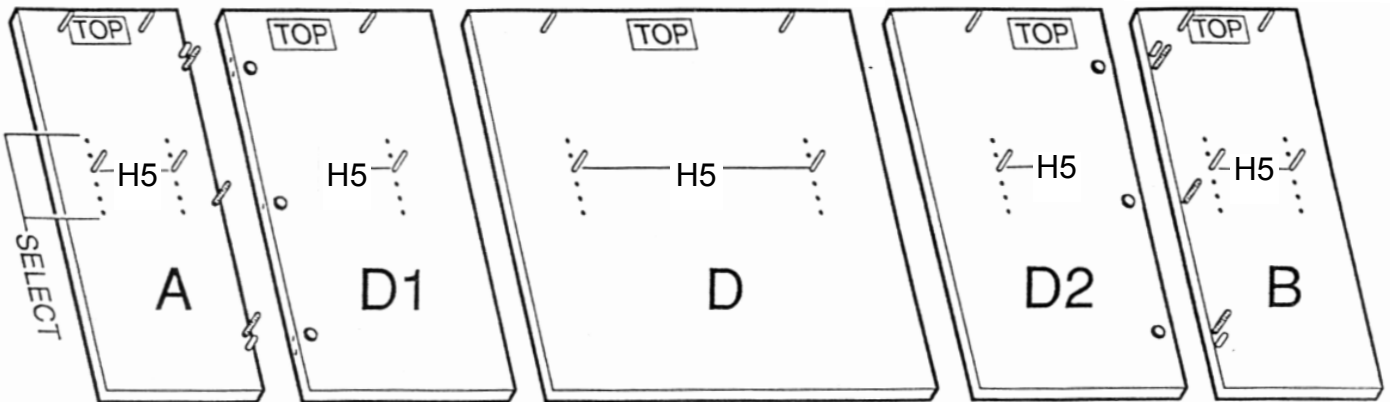

MCH42 = one Rafix Bolt
MCH48 = two Rafix Bolts

#7

Position the Left Side Panel (A) onto the Left Back panel (D1) with the top edges up as shown. Turn the arrows of the Minifix Cams (H4) clockwise to secure.

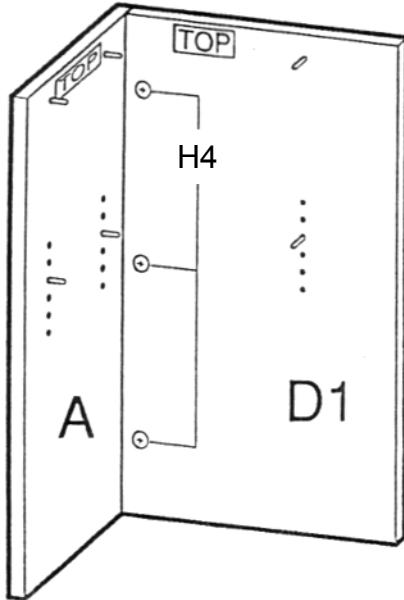
**#8**

Position the Right Side Panel (B) onto the Left Back panel (D2) with the top edges up as shown. Turn the arrows of the Minifix Cams (H4) clockwise to secure.

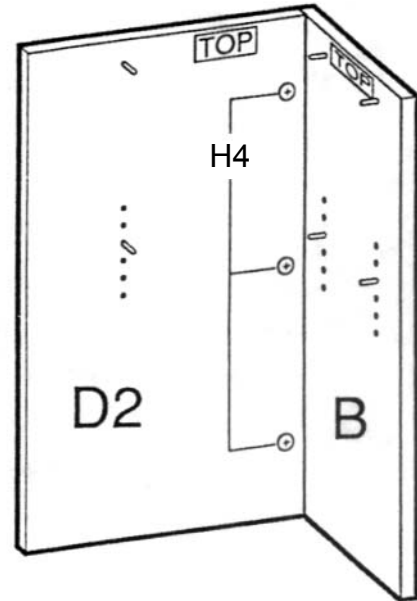
**#9**

Position the Back Panel (D) between the Left Back Panel (D1) and the Right Back Panel (D2) as shown. Attach the Back Panel to the Left Back Panel and the Right Back Panel using four MCH Angle Brackets (H6) and eight #10x5/8" Panhead Screws (H7) as shown.

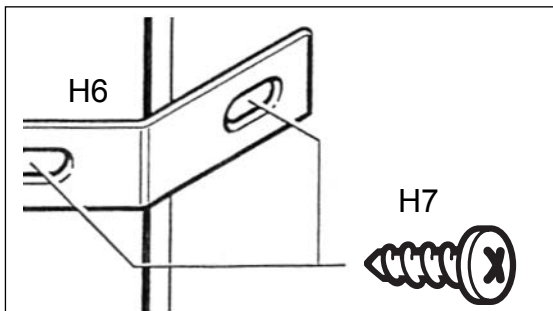

Do not fully tighten these Panhead Screws yet!

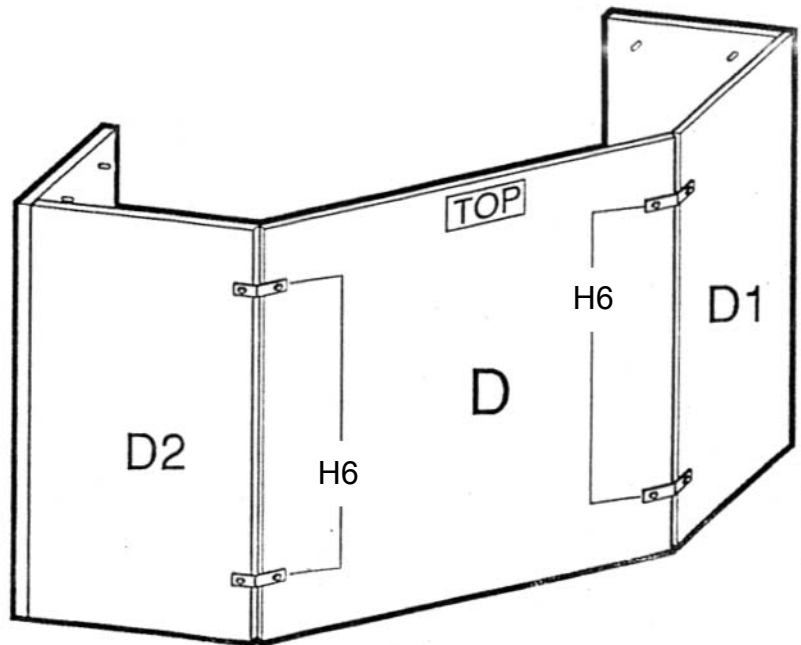

#10

With the assistance of another person, position the lower Shelf (G) onto the Rafix Bolts (H5) of the unit and turn the rotating portions of the Metal Rafix Cams (H1) a 1/4 turn clockwise to secure using a #3 screwdriver.

Do not exceed 1/4 turn when tightening cams!

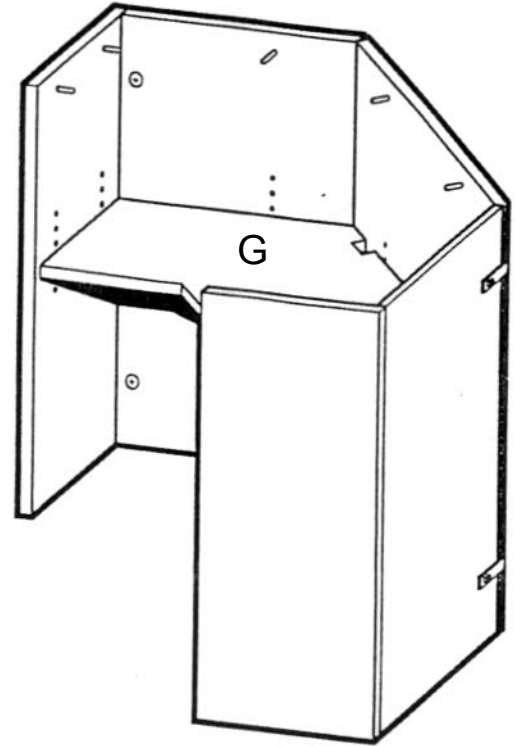
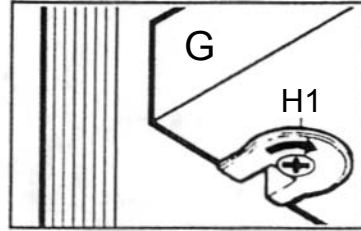

#11

With the assistance of another person, position the lower Shelf (G) onto the Rafix Bolts (H5) of the unit and turn the rotating portions of the Metal Rafix Cams (H1) a 1/4 turn clockwise to secure using a #3 screwdriver.

Do not exceed 1/4 turn when tightening cams!

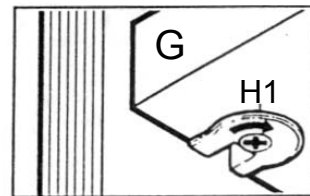
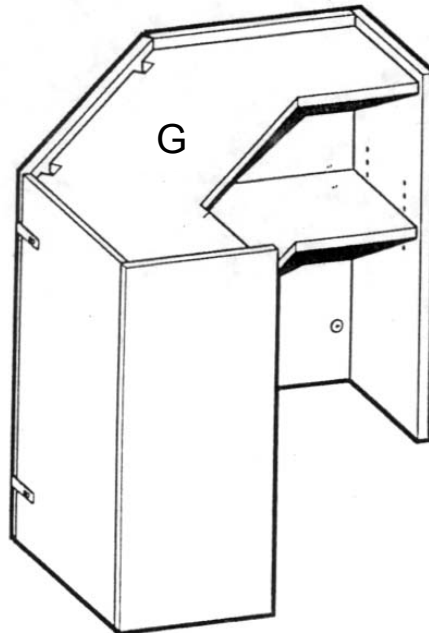

#12

At this time, tighten all the #10x5/8" Panhead Screws (H7) that secure the Angle Brackets (H6) as shown.

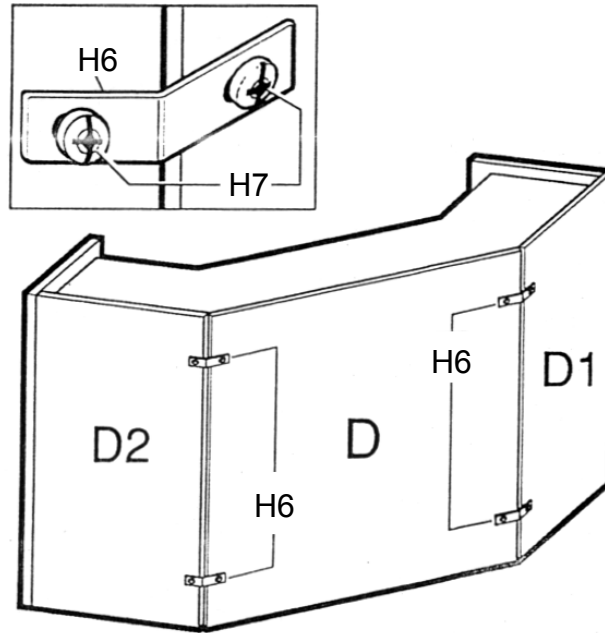

#13

With the assistance of another person, position the completed Corner Hutch onto a Corner Units.

