



The Next Necessity™

Instant Hot Water Dispensers

Model GN3-SS

Compact gooseneck design dispenses instant near-boiling 200°F water



Dimensions

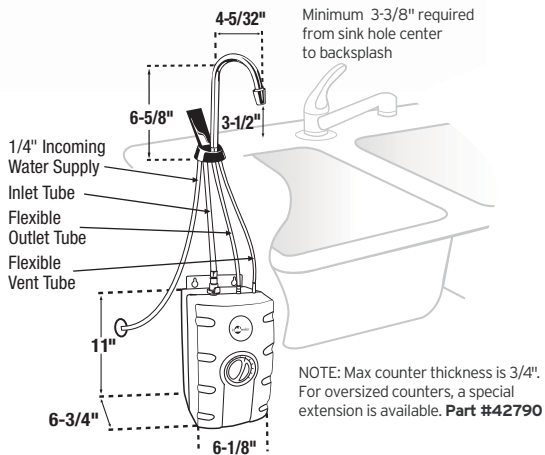

Submittal Sheet

- **Hot Only** - Dispenses near-boiling 200°F
- 35% more near-boiling water from larger 2/3-gallon stainless steel tank
- Easy to adjust temperature control
- Tool-free tank connections and dry start protection to ease installation
- Provides 60 cups/hr of near-boiling water
- 3-Year We Come To You™ In-Home Service Warranty*
- 120 volts, 750 watts, 6.25 amps
- Available in all-white, all-biscuit and all-black, or chrome with black base and handles

Sample Specification

Instant hot water dispenser(s) shall be InSinkErator Model GN3-SS with 2/3-gallon stainless steel tank, adjustable temperature from 160°F to 210°F and instant, self-closing hot valve.

Warranty:
3-year parts and in-home service.

* The complete InSinkErator warranty is included in the Care & Use booklet packed with each unit.

Specifications

Capacity	2/3-gallon stainless steel tank dispenses 60 cups of 200°F water per hour
Electrical	120 volts A.C., 750 watts, 6.25 amp heating element with grounded three (3) prong plug
Thermostat	Snap-action, adjustable from 160°F to 210°F (factory pre-set at 200°F)
Insulation	Meets U.L. 94HF-1 flammability specification
Valve	Instant, self-closing
Recommended Supply Pressure	30-125 psi
Shipping Weight	Approximately 9.75 lbs.
Required Hole Diameter	1-1/4" - 1-1/2" standard sink hole

Water Filtration System Available

Job Specifications

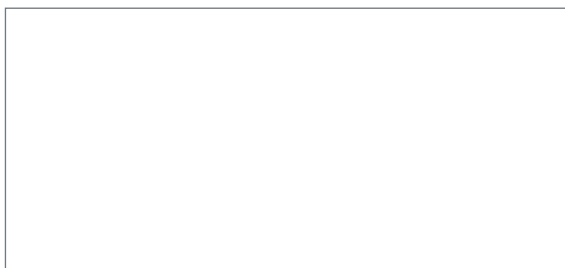

1-800-558-5700
www.insinkerator.com



The Emerson logo is a trademark and service mark of Emerson Electric Co. InSinkErator is a division of Emerson Electric Co.