



The Next Necessity™

Instant Hot Water Dispensers

Model SST-FLTR

Stainless Steel Tank dispenses filtered near-boiling 200°F water instantly

Water dispenser sold separately



Dimensions

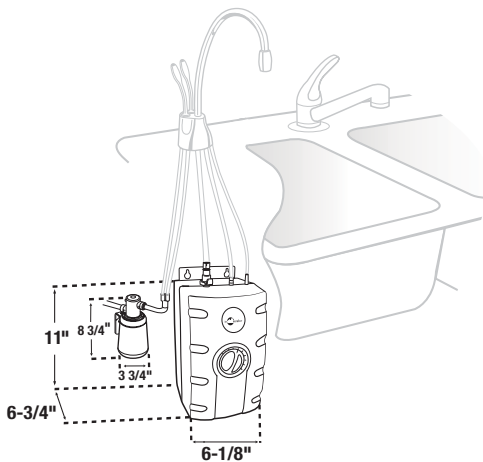

Job Specifications

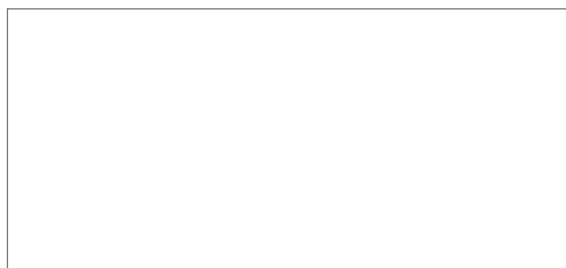

Submittal Sheet

- **35% more near-boiling water** from larger 2/3 gallon stainless steel tank
- Easy to adjust temperature control
- Tool-free tank connections and dry start protection to ease installation
- Provides 60 cups/hour of near-boiling water
- F-201 Filtration System included for fresher tasting water
 - Reduces chlorine taste and odor for clean, refreshing taste
 - Sanitary, quick-change filter cartridge makes replacement easy
 - ANSI/NSF Standard 42 (Class I)
- 120 volts, 750 watts, 6.25 amps
- For use with InSinkErator Series 1100 and other dispenser models (Not for use with Model Hot1)

Specifications

Capacity	2/3 gallon stainless steel tank dispenses 60 cups of 200°F water per hour
Electrical	120 volts, A.C., 750 watts, 6.25 amp heating element with grounded three (3) prong plug
Thermostat	Snap-action, adjustable from 160°F to 210°F (factory pre-set at 200°F)
Insulation	Meets U.L. 94HF-1 flammability specification
Recommended Supply Pressure	30-125 psi
Shipping Weight	Approximately 4.2 lbs.

Sample Specification

Instant hot water dispenser(s) shall be equipped with an InSinkErator Model SST-FLTR stainless steel tank with filtration, adjustable temperature from 160°F to 210°F and instant, self-closing hot valve.

In-Home Parts and Service Warranty*

Tank: 3-years

Filtration System: 1-year

(excluding replaceable filter cartridge)

* The complete InSinkErator warranty is included in the Care & Use booklet packed with each unit.



1-800-558-5700
www.insinkerator.com



EMERSON
Appliance Solutions

The Emerson logo is a trademark and service mark of Emerson Electric Co. InSinkErator is a division of Emerson Electric Co.