

MODEL: 50282

## ASSEMBLY INSTRUCTIONS

**READ AND SAVE THESE INSTRUCTIONS**  
**UNPACK THE FOUNTAIN**

YOU SHOULD HAVE RECEIVED THE FOLLOWING PARTS IN THE PACKAGE: FOUNTAIN BODY, UPPER LID, LOWER LID, RESERVOIR, (2) SUBMERSIBLE HALOGEN BULBS, (6) SCREWS, (6) WASHERS, METAL FRAME, A BAG OF RIVER STONES, SPLASHGUARD, TRANSFORMER AND SUBMERSIBLE PUMP. TO PROTECT THE FINISH, PLACE ALL PARTS ON A SOFT SURFACE.

### FOUNTAIN ASSEMBLY

1. ATTACH FOUNTAIN HOSE TO PUMP.
2. PLACE PUMP FLAT IN RESERVOIR.
3. PLACE FOUNTAIN BODY ONTO RESERVOIR THEN SECURE WITH WASHERS AND SCREWS.
4. PLACE THE LOWER LID IN RESERVOIR.
5. FEED LIGHT POWER CORD UP THROUGH HOLE IN FOUNTAIN BODY AND WORKING UPWARDS TOWARD TOP OF TUBE.
6. ATTACH BULB TO BULB CLIP ON UPPER LID. INSERT PINS ON UPPER LID TO TOP OF FOUNTAIN BODY. (PLEASE RETAIN THE OTHER SUBMERSIBLE HALOGEN BULB FOR FUTURE BULB REPLACEMENT.)

**FOR TABLE TOP APPLICATIONS: SKIP TO STEP #10.**  
**FOR WALL MOUNTED APPLICATIONS:**

7. PLACE THE METAL FRAME ON BACK OF FOUNTAIN AS SHOWN THEN SECURE WITH WASHERS AND SCREWS.
8. IT IS RECOMMENDED TO CONTACT YOUR LOCAL HARDWARE PROFESSIONAL TO SELECT THE MOST APPROPRIATE TYPE OF SCREWS AND ANCHORS FOR YOUR PARTICULAR WALL. FOR MOST SECURE INSTALLATION IT IS RECOMMENDED TO MOUNT THE FOUNTAIN DIRECTLY INTO A WALL STUD.
9. MOUNT FOUNTAIN TO WALL.
10. ATTACH SPLASHGUARD TO RESERVOIR AS SHOWN.
11. PLACE RIVER STONES ON LOWER LID.
12. FILL RESERVOIR WITH ENOUGH WATER TO COMPLETELY SUBMERSE PUMP. (DISTILLED WATER IS RECOMMENDED BY US IN THE FOUNTAIN TO REDUCE MINERAL DEPOSITS AND BACTERIA BUILD UP.)
13. JOIN THE CONNECTORS TOGETHER.
14. PLUG THE TRANSFORMER INTO SOCKET AND TURN ON AT SWITCH. YOUR FOUNTAIN IS READY TO USE.

### TROUBLE SHOOTING:

1. IF YOUR FOUNTAIN DOES NOT WORK, CHECK PLUG AT THE SOCKET. MAKE SURE THE PLUG IS FULLY AND PROPERLY INSERTED INTO THE WALL OUTLET.
2. NEXT CHECK TO MAKE SURE THE OUTLET IS POWERED.
3. IF THE FOUNTAIN STILL DOES NOT WORK, PLEASE CONTACT YOUR DISTRIBUTOR OR PLACE OF PURCHASE.

### SPLASHING DISCLAIMER:

SPLASHING MAY OCCUR WHEN FOUNTAIN IS INITIALLY TURNED ON. PROTECT SURROUNDING SURFACES AS NEEDED.

### IMPORTANT PUMP INFORMATION:

PUMP MUST BE FULLY SUBMERSED IN WATER WHILE OPERATING.

### WATER:

TO REDUCE MINERAL DEPOSITS AND BACTERIA BUILD UP THE USE OF DISTILLED WATER IS RECOMMENDED.

### IMPORTANT SAFETY INSTRUCTIONS:

THIS FOUNTAIN IS RATED FOR INDOOR USE ONLY.

### WARNING:

ONCE A WEEK INSPECT FOUNTAIN, FLOOR AND ADJACENT WALL FOR MOISTURE BUILD-UP AND CLEAN AS NECESSARY. THIS IS ESPECIALLY IMPORTANT FOR HUMID ENVIRONMENTS.

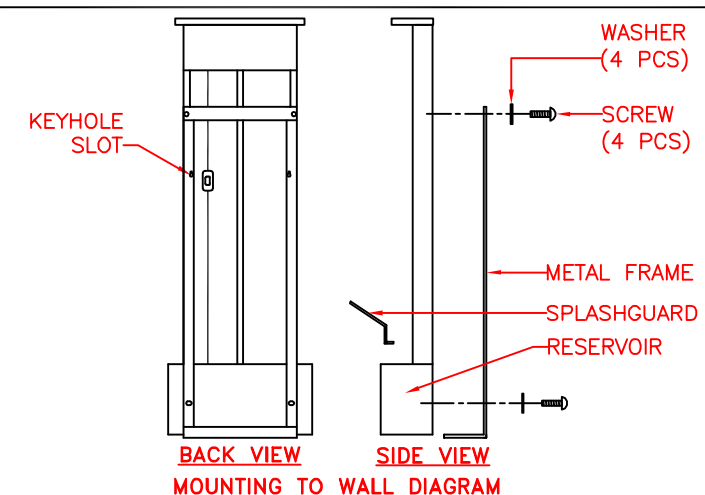
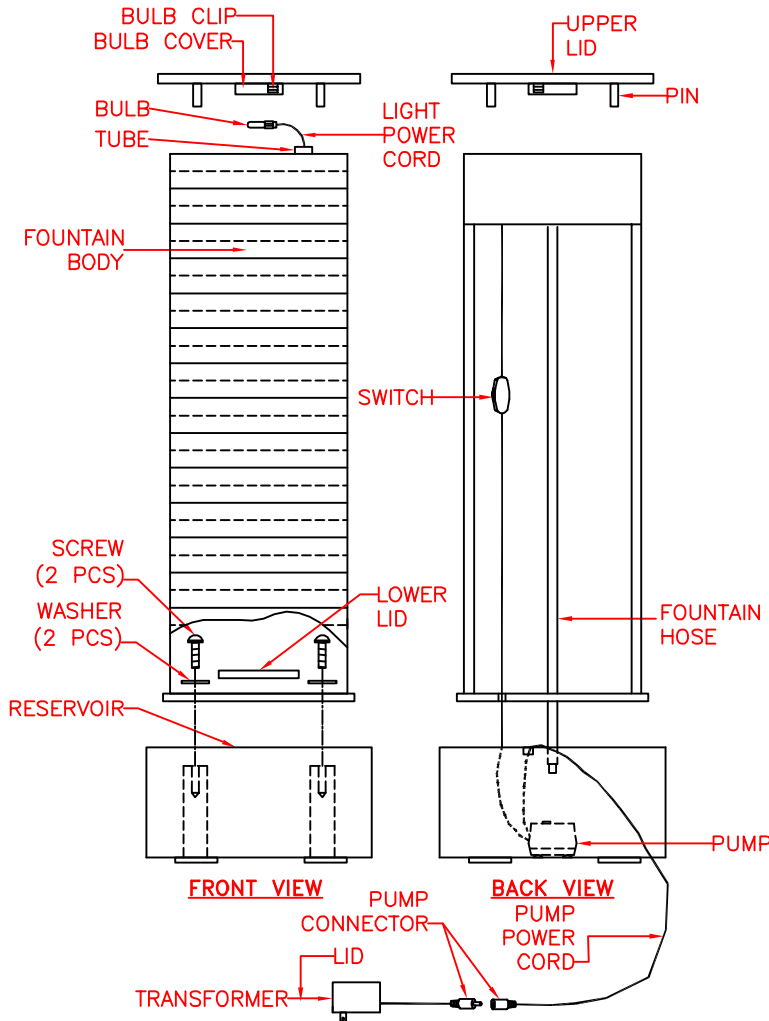

### WARNING:

THIS UNIT MUST BE CONNECTED TO A SUPPLY CIRCUIT THAT IS PROTECTED BY A GROUND FAULT CIRCUIT INTERRUPTER (GFCI). THE GFCI SHOULD BE TESTED ON A ROUTINE BASIS. TO TEST THE GFCI, PUSH THE TEST BUTTON. THE GFCI SHOULD INTERRUPT POWER. PUSH THE RESET BUTTON. POWER SHOULD BE RESTORED. IF THE GFCI FAILS TO OPERATE IN THIS MANNER, THE GFCI IS DEFECTIVE.