

88 5325 38 Sliding Door Cabinet (Antique Black Finish)

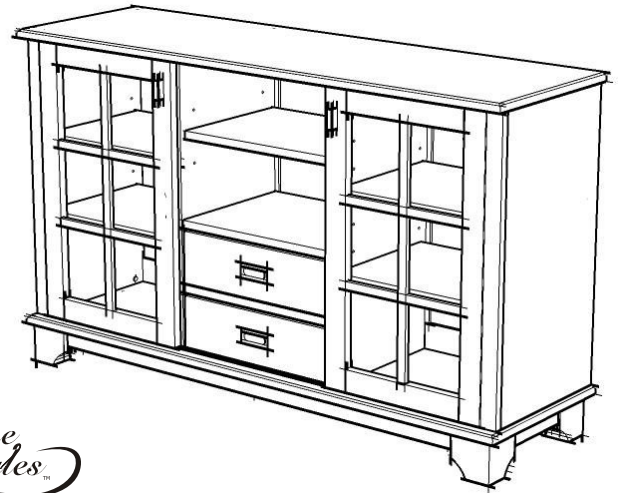

IMPORTANT NOTE

Carefully remove all the parts from the carton and put them individually on a soft cloth to prevent scratches or other damages occurring to the wood parts.

We have taken great care in the design of this product and request that you carefully and strictly follow our assembly instructions to ensure a completed product as it was designed.



Casual Attire For Today's Home

Thai Patent Pending Numbers 106300

Part List

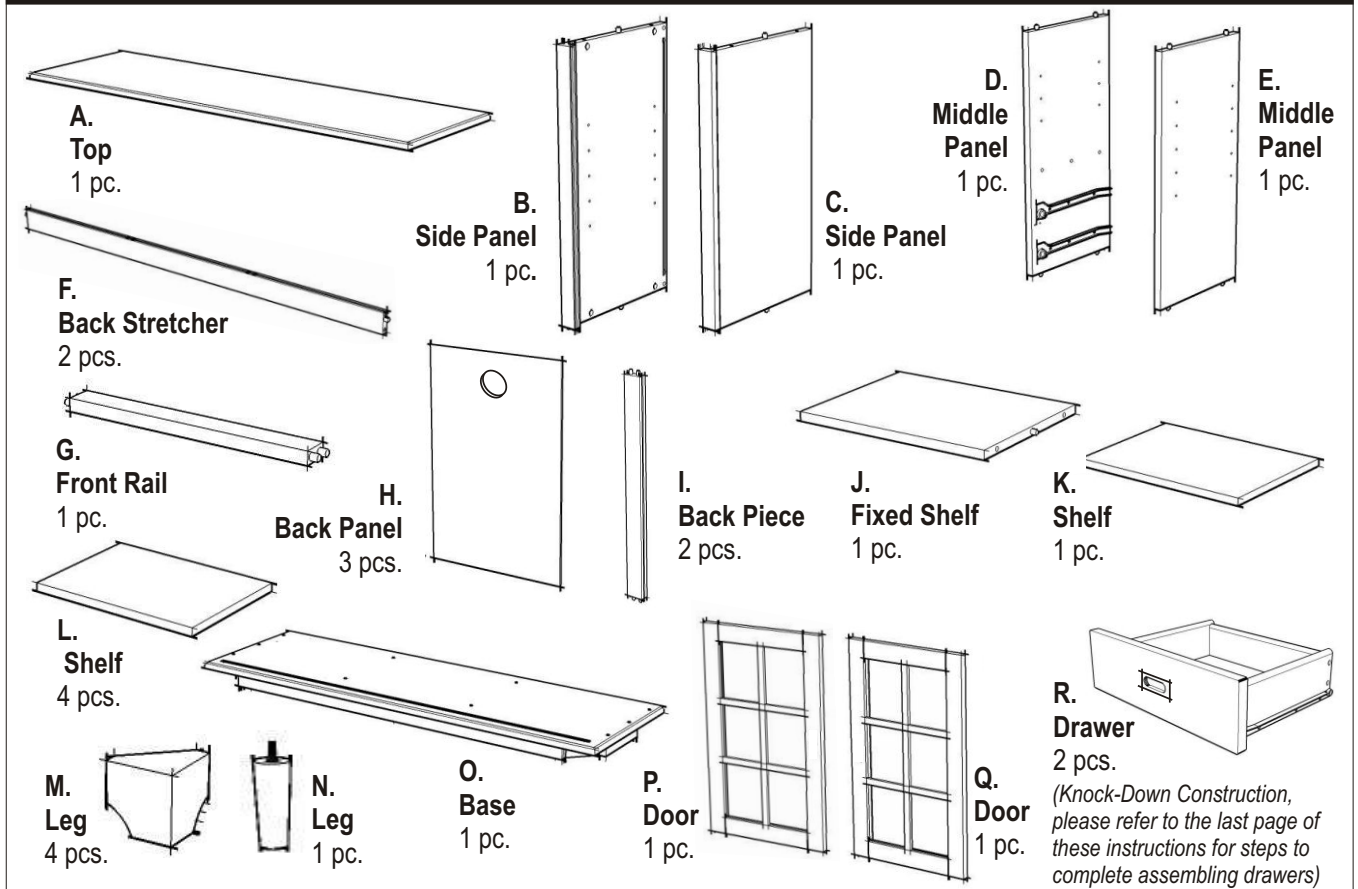

Hardware List

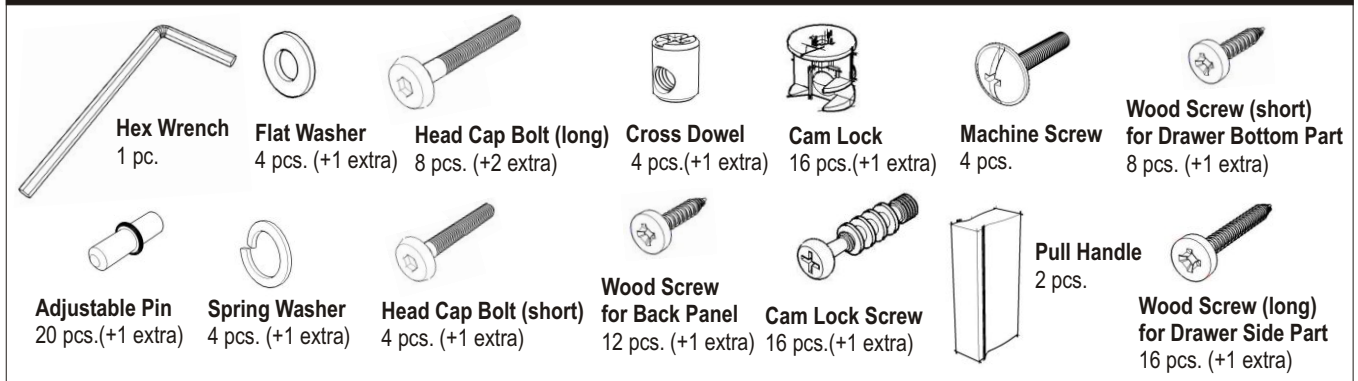

Tools required for assembly: Philips screwdriver

Assembly Instructions 2/5

IMPORTANT

Do not tighten up all the screws until each part is properly assembled. You should keep Hex Wrench in the safe place as you may need to tighten up the Head Cap Bolts in the future.

STEP 1

Insert Cam Lock Screws into the pre-drilled holes of Side Panel (B) and (C). (See figure 1)

Attach Back Stretcher (F) to the Side Panel (B) with Cam Lock.

Attach Back Panel (H) and Back Piece (I) to the Back Stretcher (F).

Attach another Back Stretcher (F) and Side Panel (C) to the unit with Cam Locks.

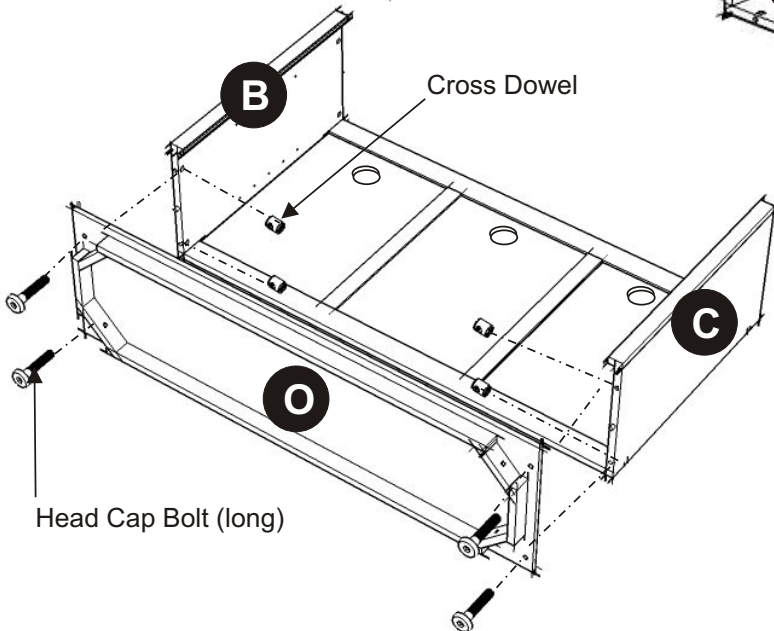
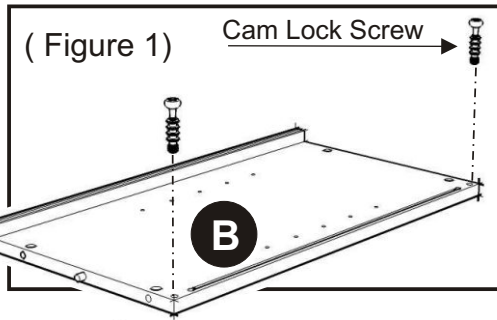
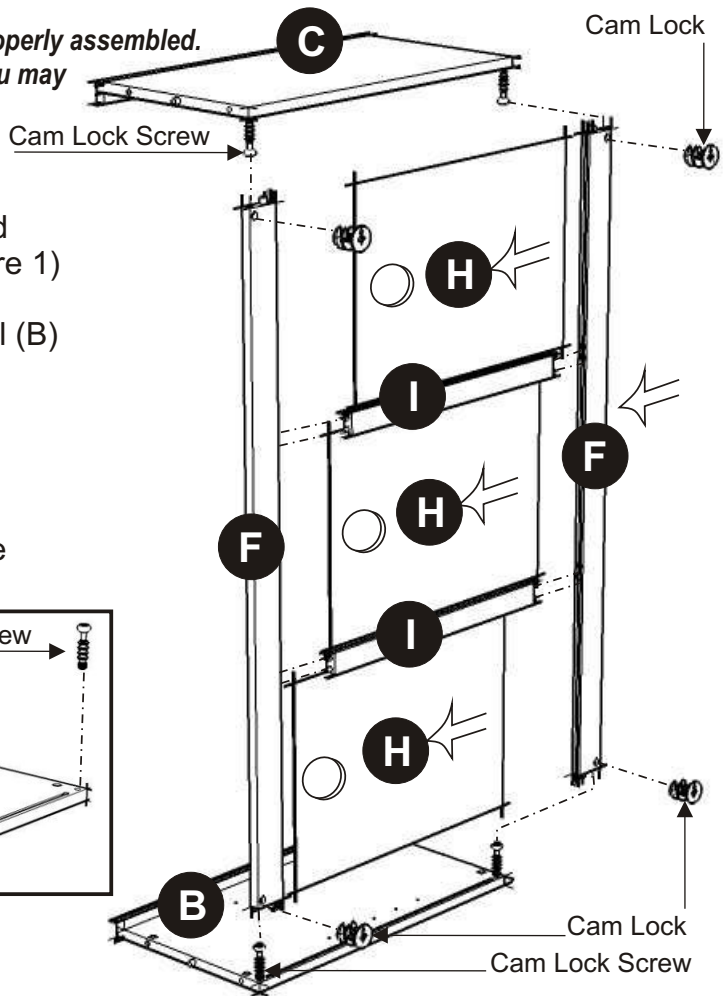

STEP 2

Attach Base (O) to the unit, using Head Cap Bolts (long) and Cross Dowels.

Attach Leg (M) to Base (N), using Flat Washer, Spring Washer and Head Cap Bolts (long). (See figure 2)

Insert Leg (N) into a pre-drilled hole and tighten up.

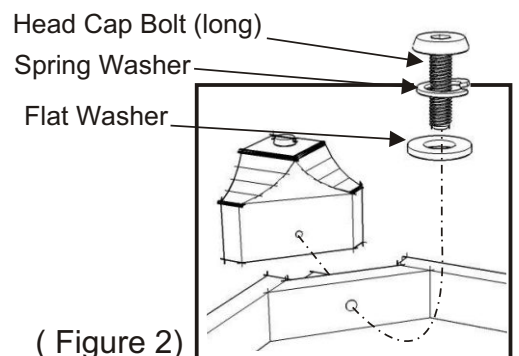
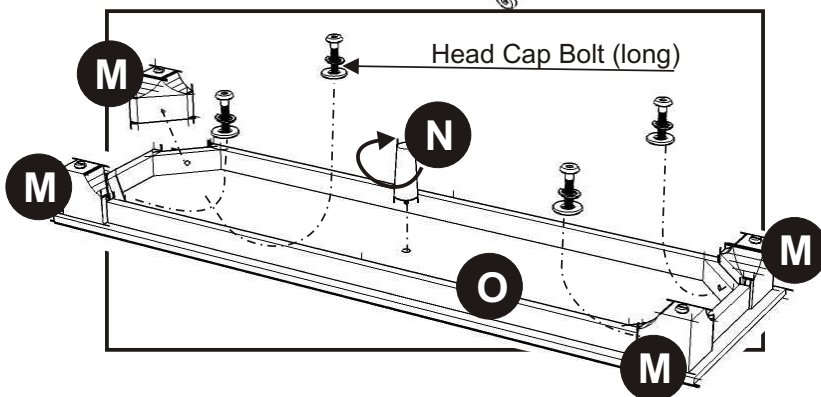

STEP 3

Turn the unit back to its normal position,

Attach Middle Panel (D) to the unit with Head Cap Bolts (long).

Attach Front Rail (G), Fixed Shelf (J) to the Middle Panel (D) with Cam Lock Screws and Cam Locks.

Attach Middle Panel (E) to the unit with Cam Lock Screws and Head Cap Bolts (long).

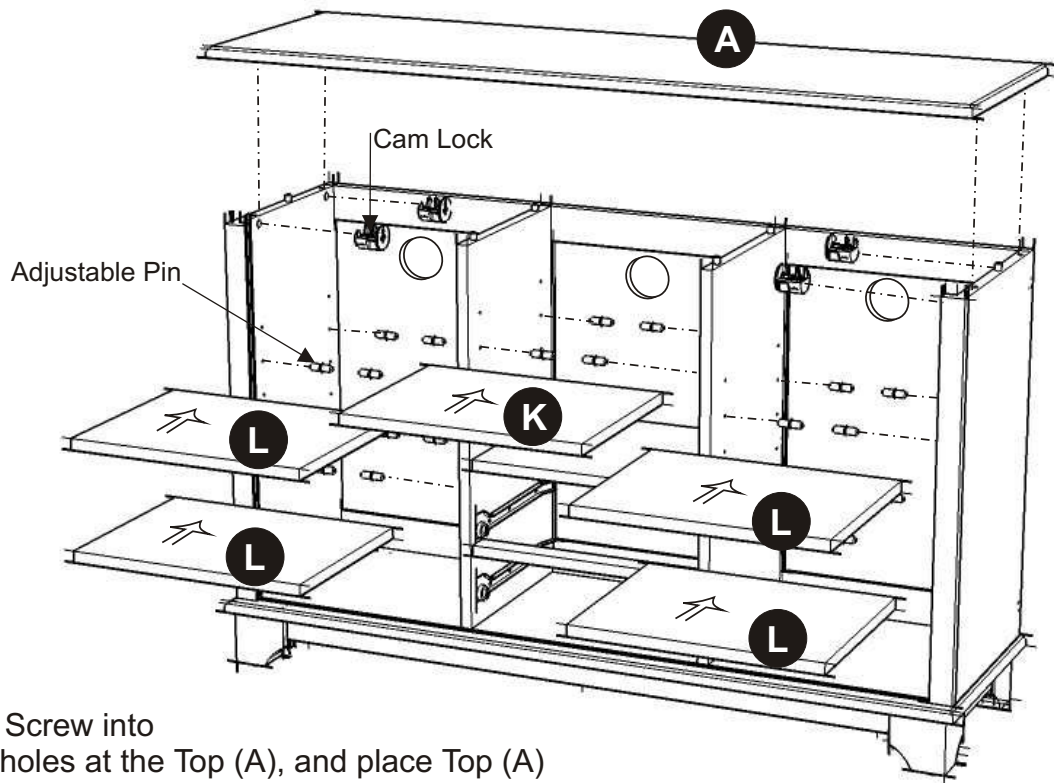
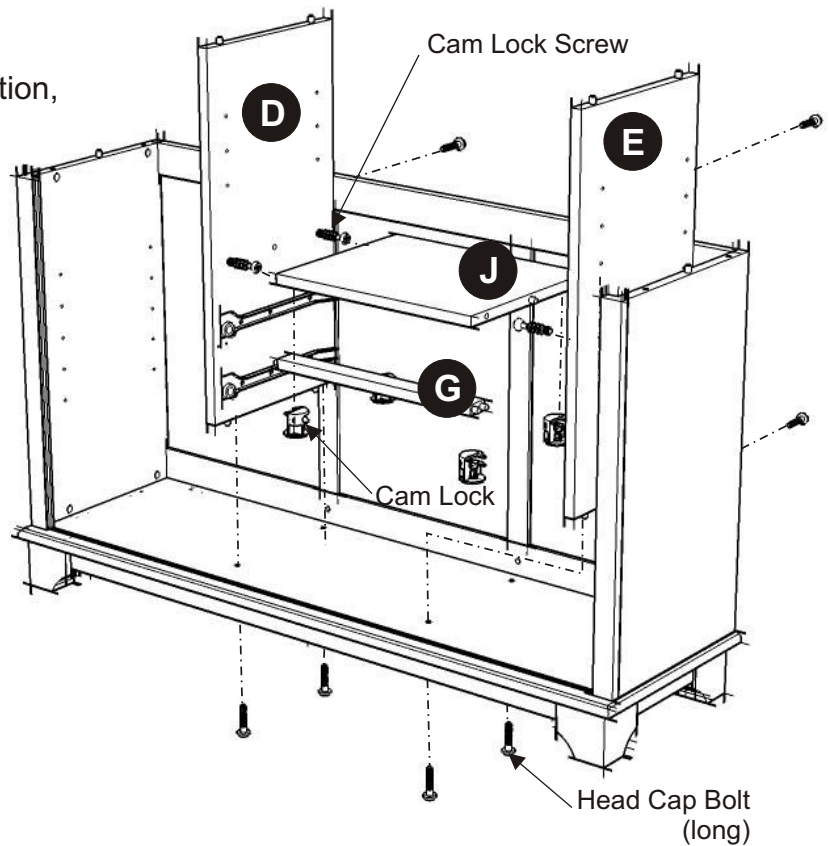

STEP 4

Put Cam Lock Screw into the pre-drilled holes at the Top (A), and place Top (A) onto the unit, using Cam Locks.

Insert Adjustable Pins into Side Panel (B), (C) and Middle Panel (D), (E) at the desired level.

Slide Shelf (K) and (L) into place.

Assembly Instructions 4/5

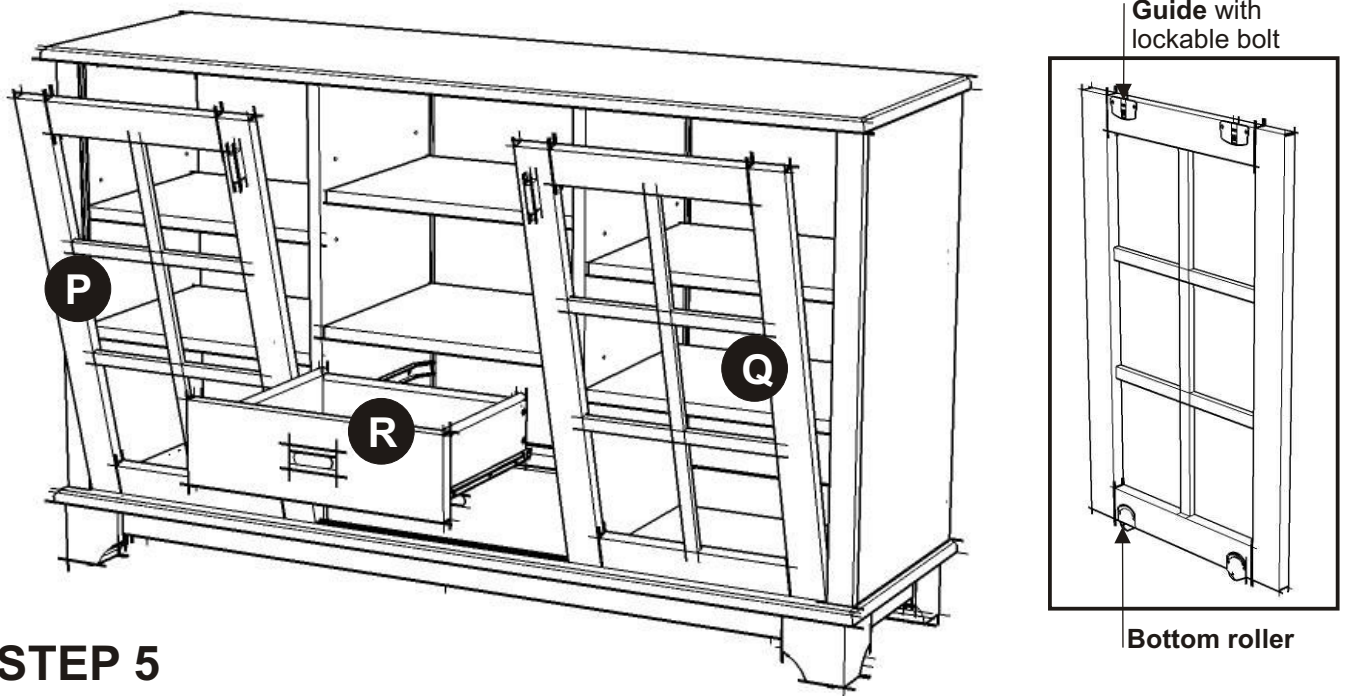

STEP 5

Assemble Pull Handle to the Door (P) and (Q) with Machine Screw. (See figure 3)

Before installing the door, check that the Guide to be in unlocked position. (See figure 4)

Put the Door (P) into the groove; flip up the lockable bolts of the Guides. (See figure 5)

Do the same process for the Door (Q).

Slide the Drawer (R) into place.

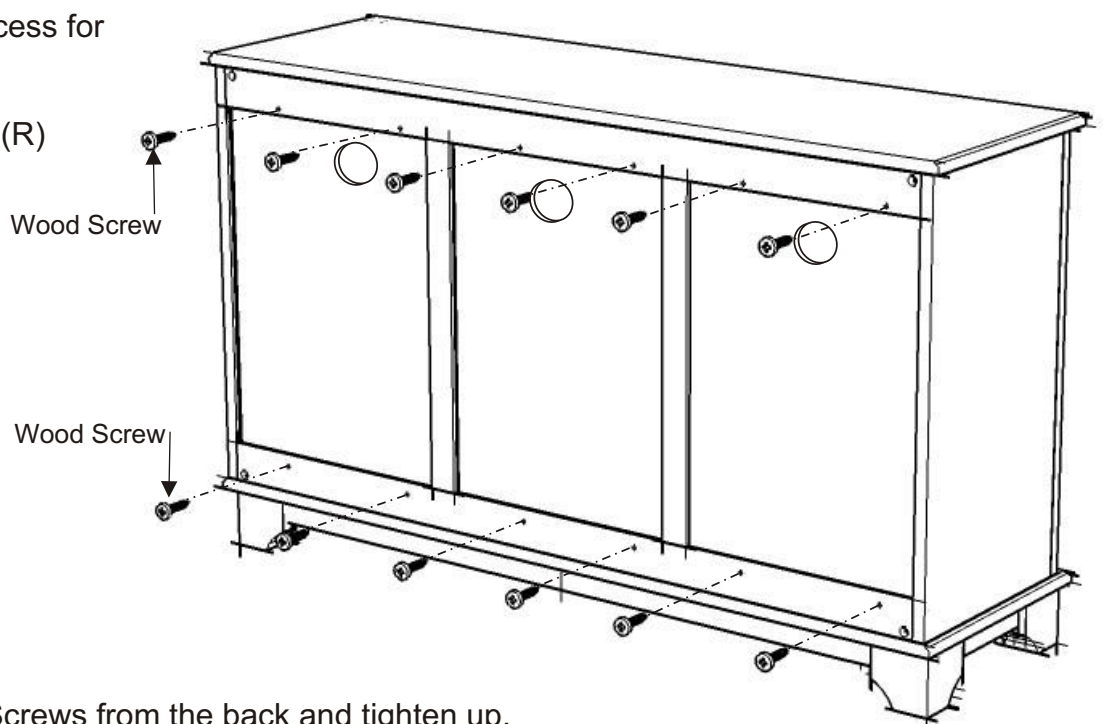
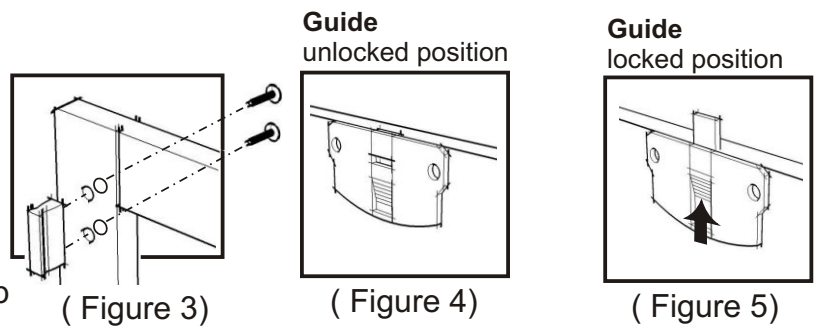

STEP 6

Insert 12 Wood Screws from the back and tighten up.

Drawer

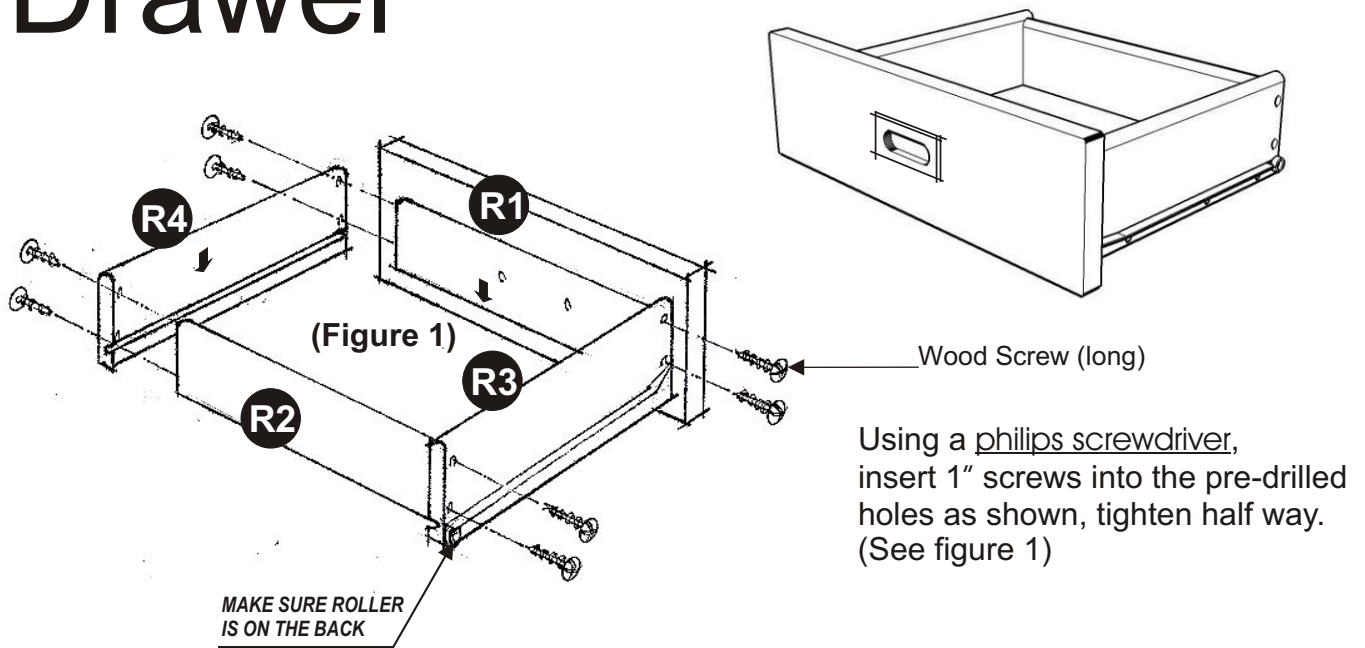

Slide the Plywood Base Part (R5) into the grooves on Side Parts (R3) and (R4). Be sure to push the plywood all the way forward so it meets the Front Part (R1).

Insert the remaining (6) 1/2" screws into the pre-drilled holes on Base Part (R5), then tighten all screws. (See figure 2)

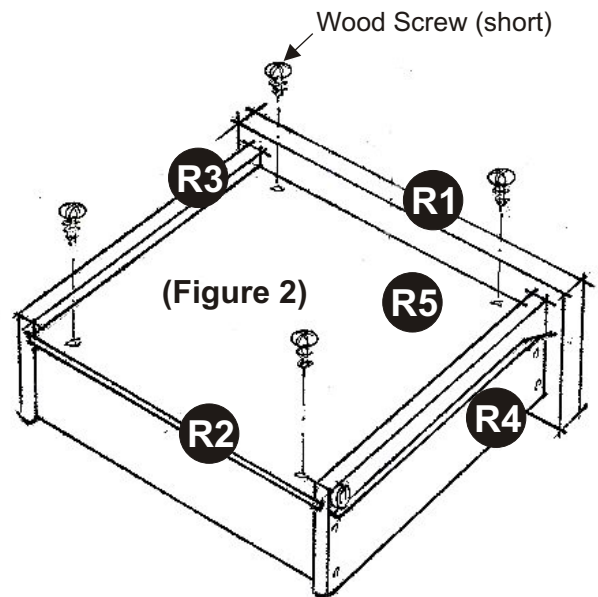

* If you are missing any of these parts, please contact our DMI Customer Service Department at 1-877-831-0319 or fax us at 1-800-755-2878.

Part List

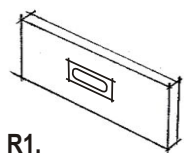

R1.
Front Part
2 pcs.

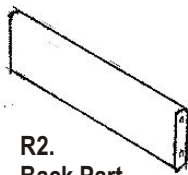

R2.
Back Part
2 pcs.

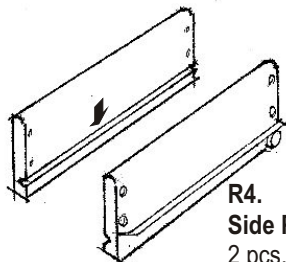

R3.
Side Part
2 pcs.

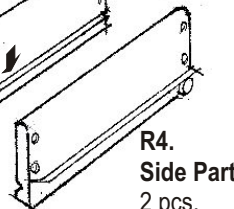

R4.
Side Part
2 pcs.

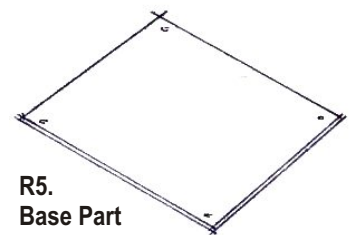

R5.
Base Part
2 pcs.