

Examine all packaging material for small parts that may have come loose during shipment. Periodic checks are recommended to insure that all components are in proper position, tight and free from damage. Keep this assembly instruction for future reference. Adult assembly required. Online Parts Request Form: www.hillsdalehouse.com/parts_request.html

HARDWARE LIST

- A (4) Medium Allen Bolts
- B (13) Large Metal Washers
- C (21) Spring Washers
- D (15) Small Allen Bolts
- E (6) Long Allen Bolts
- F (4) Wood Screws
- G (12) Small Metal Washers
- H (1) Allen Wrench

PARTS LIST

- J (1) Back Panel
- K (1) Seat Base
- L (2) Leg Panels
- M (1) Top Inner Ring
- N (1) Bottom Ring
- P (1) Seat Cushion
- R (1) Support Ring

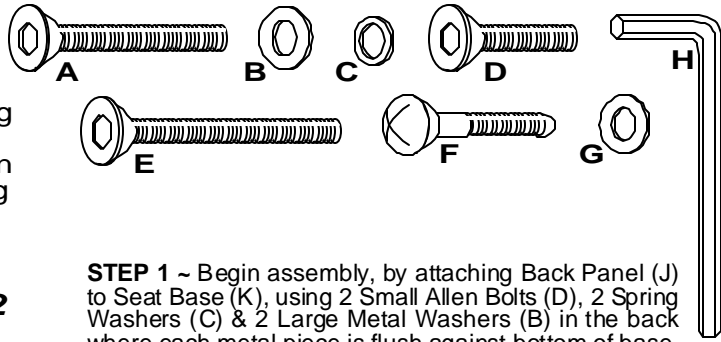

FIGURE 1

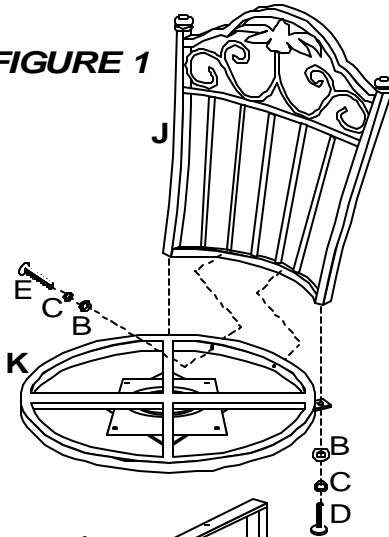
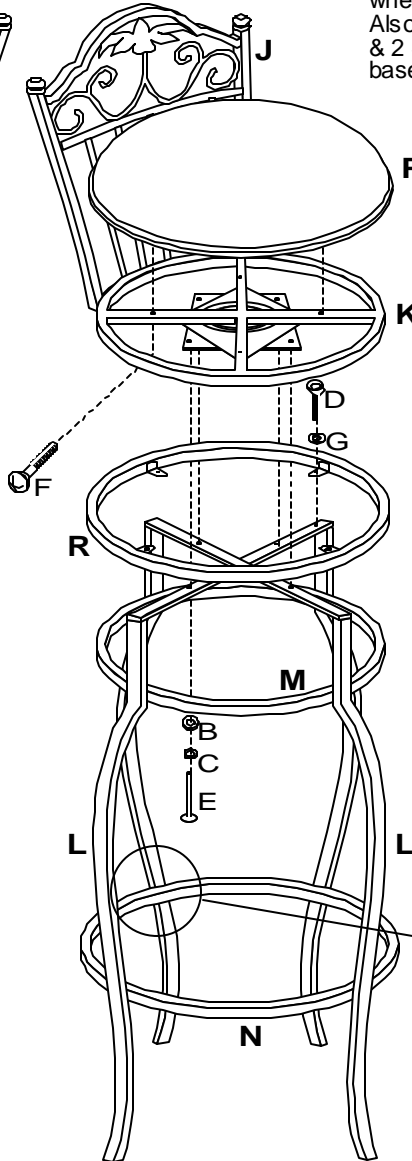

FIGURE 2



STEP 1 ~ Begin assembly, by attaching Back Panel (J) to Seat Base (K), using 2 Small Allen Bolts (D), 2 Spring Washers (C) & 2 Large Metal Washers (B) in the back where each metal piece is flush against bottom of base. Also, use 2 Long Allen Bolts (E), 2 Spring Washers (C) & 2 Small Metal Washers (B) from the inside of the seat base. Tighten all bolts. See Figure 1.

STEP 2 ~ Next, attach both Leg Panels (L) by crossing them between each other, and attach Top Inner Ring (M) to inside of each panel using 1 Medium Allen Bolt (A), 1 Spring Washer (C) & 1 Small Metal Washer (B) per each leg. Only hand tighten bolts for this step. See Figure 1.

STEP 3 ~ Attach Support Ring (R) to both Leg Panels (L) using 4 Short Allen Bolts (D) & 4 Large Metal Washers (G) to hold in place. Screw in each bolt through tabs and into each leg panel. Make sure that tabs are flush with cross arms on leg panels. Only hand tighten bolts for this step. See Figure 2.

STEP 4 ~ Attach Bottom Ring (N) to both Leg Panels (L) using 2 Short Allen Bolts (D), 2 Spring Washers (C) & 2 Large Metal Washers (G) per each leg. Tighten all bolts from steps 2 & 3. See Figure 3.

STEP 5 ~ Attach remaining stool pieces, the top section and the bottom section by attaching swivel piece connected to Seat Base (K) to both Leg Panels (L), using 4 Long Allen Bolts (E), 4 Spring Washers (C) & 4 Small Washers (B) to hold in place. Tighten all bolts. See Figure 2.

STEP 6 ~ Attach Seat Cushion (P) to Seat Base (K), using 4 Wood Screws (F) to hold in place. Tighten all screws, assembly is now complete.

FIGURE 3

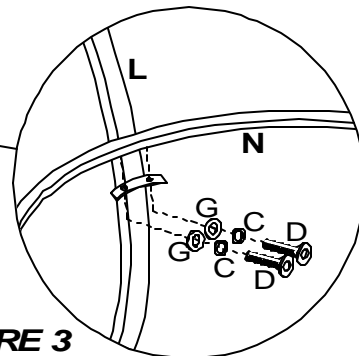

CARE & MAINTENANCE: The touch of a soft cloth is all the maintenance the finish will ever need. Please do not use harsh or abrasive cleaners for polishing, as they may cause damage to the finish. Periodic checks are recommended to make sure that all bolts, screws and nuts are securely tightened.