

*Installation Instructions / Warranty*



*Interaktiv*  
Bar Sink Faucet

**hansgrohe**  
**interaktiv**

90551001 1/2005

## **Interaktiv Bar Sink Faucet**

**06688XX0**

**06693XX0**

**06696XX0**

**06699XX0**

**06857XX0**

### **Product Specification**

Recommended operating pressure	14.7 - 72.5 PSI
Recommended incoming hot water temp.	120° - 140° F*
Hole size in mounting surface	1-1/2"
Maximum mounting surface depth	2 3/8"
Flow Rate	2.2 GPM
M3 Cartridge with high temperature limit stop	

\*Some governing bodies require that the water heater be set to 120° F or less. Please know and follow all applicable local codes when setting the temperature on the water heater.

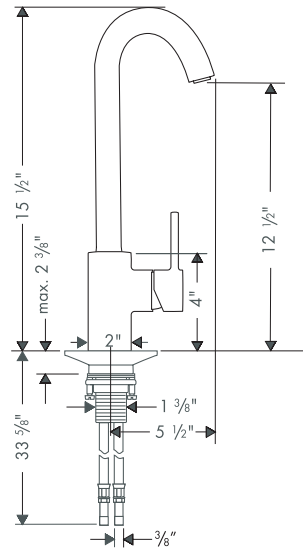

### **Installation Considerations**

FOR BEST RESULTS, HANSGROHE RECOMMENDS THAT THIS UNIT BE INSTALLED BY A LICENSED, PROFESSIONAL PLUMBER.

Please read over these instructions thoroughly before beginning installation. Make sure that you have all tools and supplies needed to complete the installation.

**The hot and cold supply hoses on this faucet require supply stops with 3/8" compression fittings. Hansgrohe does not provide supply stops or compression fittings.**

## Installation Instructions

- Place the black sealing ring and the faucet on top of the mounting surface.
- From below the mounting surface, install the plastic washer, fiber washer, metal friction washer, and mounting nut. If there is insufficient space, or if the countertop is thicker than 1 3/8", install the faucet without the plastic washer.

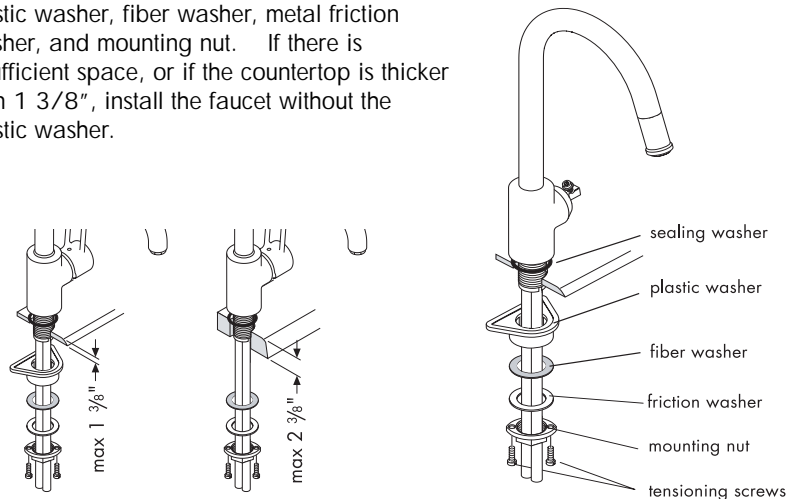

- Tighten the mounting nut. Use a flat-bladed screwdriver to tighten the tensioning screws.
- Attach the supply lines to the supply stops with standard 3/8" compression fittings (not included). Slide the compression nut and ferrule over the hose shank. Insert the shank into the supply stop. Tighten the compression nut finger tight, then finish tightening with a wrench.
- Turn on the water and check all connections for leaks.

## Install the handle

Install the Boltic™ handle screw to the stem. Tighten only 4 turns.

Place the handle over the stem and handle screw. Press the handle firmly into place.

Use the 4mm hex wrench to finish tightening the screw.

Install the screw cover.

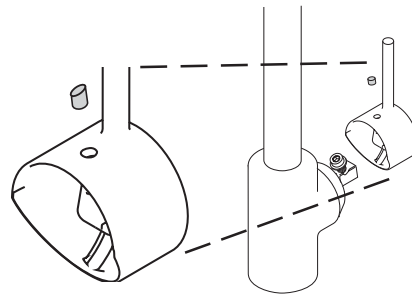

## ***User Instructions***

The spout on this faucet swivels a full 360°. ***Do not swivel the spout further than 360°, or damage to the hose will result.***

Push the handle to the right to turn the water on. Push it back to the left to turn the water off. Swivel the handle forward for cooler water, backward for warmer water.

### ***NOTE: The faucet "lay down" function***

If necessary, to provide clearance for opening a window, or for other reasons, the faucet can be laid down on the counter without uninstalling it. Pull up on the faucet, then gently lay it down on the countertop.

When replacing the faucet, make sure that the pin on the bottom of the faucet goes into the hole on the base. Push the faucet down firmly against the base.

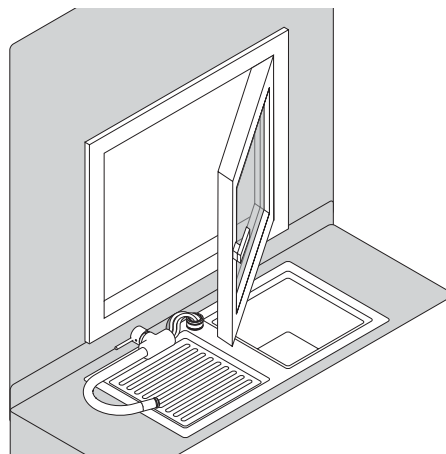
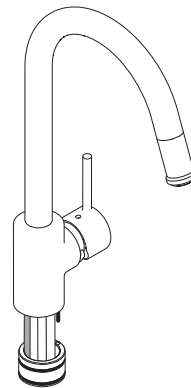

## Set the High Temperature Limit Stop (optional)

- Turn off the water at the supply stops – usually located under the sink. Turn on the faucet to confirm that the water is off.

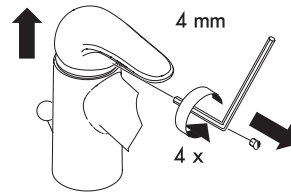

- Close the drain OR cover it with a wash cloth. Use the 4 mm hex wrench to push the screw cover into the handle. Retrieve the screw cover when the handle is removed.

- Use a 4mm hex wrench to loosen the handle screw (4 complete revolutions). Remove the handle. Place the handle in a safe place.

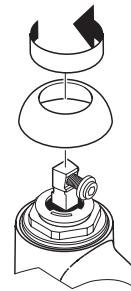

- Remove the decorative nut cover and set aside.

- Remove the handle screw from the stem of the cartridge. Remove the high temperature limit stop

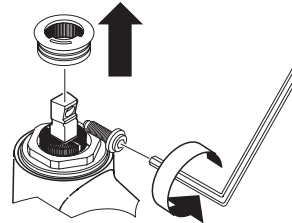

- Replace the high temperature limit stop so that the pin on the cartridge is in the desired slot on the limit stop. **Note: the temperatures given in the diagram assume a water heater temperature of 140° F, a cold water temperature of 50° F, and a water pressure of 45 PSI. Your high temperature may vary.**

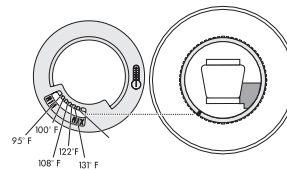

- Replace the decorative nut cover. Replace the handle screw. Use the hex wrench to turn the screw 4 revolutions.

- Replace the handle. Finish tightening the handle screw. Turn on the water and test the faucet.

## ***Cleaning Recommendation for Hansgrohe Products***

Modern faucetry and shower products utilize a combination of materials to comply with the needs of the market with regard to design and functionality.

To avoid damage, it is necessary to use some caution when cleaning. Damage caused by improper treatment is not covered under the Hansgrohe warranty.

### ***Cleaning Materials for Faucets and Showers***

- To remove lime scale, use only products made specifically for that purpose. Always follow the manufacturer's instructions when using.
- Do not use cleaners that contain hydrochloric, formic, acetic, or phosphoric acids, as these will cause considerable damage to finishes and to plastic components.
- Never mix cleaning materials.
- Never use cleaners containing abrasives. Do not use abrasive cleaning cloths, pads, or sponges.

### ***Cleaning Procedures***

- Clean your faucets and shower products as and when required. Regular cleaning will prevent scale buildup and water spotting.
- Follow the label instructions. Do not allow any cleaner to remain on the product for longer than necessary.
- When using spray cleaners, spray first onto a sponge or cloth – do not spray directly onto the product.
- After cleaning, rinse thoroughly with clear water to remove any cleaner residue.

### ***Important***

- Soap and shampoo residue can also cause damage to the product. Rinse well with clean water after use.
- If the surface is already damaged, harsh cleaning materials will cause further damage.

## ***Limited Lifetime Consumer Warranty***

This product has been manufactured and tested to the highest quality standards by Hansgrohe, Inc. ("Hansgrohe"). This warranty is limited to Hansgrohe products which are purchased by a consumer in the United States after March 1, 1996, and installed in either the United States or Canada.

### ***WHO IS COVERED BY THE WARRANTY***

This warranty extends to the original consumer purchaser only.

### ***WHAT IS COVERED BY THE WARRANTY***

This warranty covers only your Hansgrohe manufactured product. Hansgrohe warrants this product against defects in material or workmanship as follows: Hansgrohe will repair at no charge for parts only or, at its option, replace any product or part of the product which proves defective because of improper workmanship and/or material, under normal installation, use, service and maintenance. If Hansgrohe is unable to provide a replacement and repair is not practical or cannot be timely made, Hansgrohe may elect to refund the purchase price in exchange for the return of the product.

### ***LENGTH OF WARRANTY***

Replacement or repaired parts of products will be covered for the term of this warranty as stated in the following two sentences. If you are a consumer who purchased the product for use primarily for personal, family, or household purposes, this warranty extends for as long as you own the product and the home in which the product is installed. If you purchased the product for use primarily for any other purpose, including, without limitation, a commercial purpose, this warranty extends only (i) for 1 year, with respect to Interaktiv and Retroaktiv products, and (ii) for 5 years, with respect to AXOR, ShowerPower and Pharo products.

***THIS WARRANTY DOES NOT COVER, AND HANSGROHE WILL NOT PAY FOR:***

- A. Conditions, malfunctions or damage not resulting from defects in material or workmanship.
- B. Conditions, malfunctions or damage resulting from (1) improper installation, improper maintenance, misuse, abuse, negligence, accident or alteration, or (2) the use of abrasive or caustic cleaning agents or "no rinse" cleaning products, or the use of the product in any manner contrary to the product instructions.
- C. Labor or other expenses for the disconnection or return of the product for warranty service, or for installation or reinstallation of the product.
- D. Accessories or related products not manufactured by Hansgrohe.

***TO OBTAIN WARRANTY SERVICE***

Contact your Hansgrohe retailer, or write to Technical Service at:

Hansgrohe Inc.  
1492 Bluegrass Lakes Parkway  
Alpharetta GA 30004

Or, call Hansgrohe toll-free at (800) 334-0455.

In requesting warranty service, you will need to provide

1. The sales receipt or other evidence of the date and place of purchase.
2. A description of the problem.
3. Delivery of the product or the defective part, postage prepaid and carefully packed and insured, to Hansgrohe Inc. 1492 Bluegrass Lakes Parkway, Alpharetta, Georgia 30004, Attention: Technical Service, if required by Hansgrohe.

When warranty service is completed, any repaired or replacement product or part will be returned to you postage prepaid.

***EXCLUSIONS AND LIMITATIONS***

***REPAIR OR REPLACEMENT (OR, IN LIMITED CIRCUMSTANCES, REFUND OF THE PURCHASE PRICE) AS PROVIDED UNDER THIS WARRANTY IS THE EXCLUSIVE REMEDY OF THE PURCHASER. HANSGROHE NEITHER ASSUMES NOR AUTHORIZES ANY PERSON TO CREATE FOR IT ANY OBLIGATION OR LIABILITY IN CONNECTION WITH THIS PRODUCT.***

***HANSGROHE SHALL NOT BE LIABLE TO PURCHASER OR ANY PERSON FOR ANY INCIDENTAL, SPECIAL, OR CONSEQUENTIAL DAMAGES, ARISING OUT OF BREACH OF THIS WARRANTY OR ANY IMPLIED WARRANTY (INCLUDING MERCHANTABILITY).***

Some States do not allow the exclusion or limitation of incidental or consequential damages, so the above limitation or exclusion may not apply to you.

This warranty gives you specific legal rights, and you may have other rights which vary from State to State.

You may be required by law to give us a reasonable opportunity to correct or cure any failure to comply before you can bring any action in court against us under the Magnuson-Moss Warranty Act.

***PRODUCT INSTRUCTIONS AND QUESTIONS***

Upon purchase or prior to installation, please carefully inspect your Hansgrohe product for any damage or visible defect. Prior to installing, always carefully study the enclosed instructions on the proper installation and the care and maintenance of the product. If you have questions at any time about the use, installation, or performance of your Hansgrohe product, or this warranty, please call or write to us at the toll-free number and address printed above.

**hansgrohe**

Hansgrohe, Inc. • 1490 Bluegrass Lakes Parkway • Alpharetta, GA 30004  
Tel. 770 360-9880 • Fax 770 360 9887  
[www.hansgrohe-USA.com](http://www.hansgrohe-USA.com)