

COMPACT CRIB EVACUATION FRAME

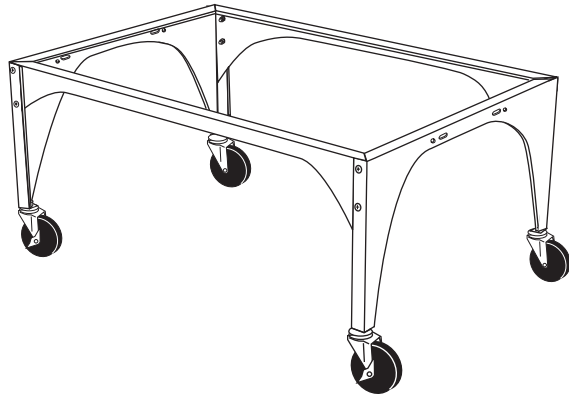

ASSEMBLY INSTRUCTIONS

For use only with Foundation Compact Cribs.

⚠ WARNING

- Evacuation Frame Kit contains screws and small parts that can be hazardous to children before assembly. **MUST** be assembled by an adult.
- When evacuating children, children **MUST** be seated in crib.
- When using evacuation frame with a crib with an adjustable mattress support, mattress support **MUST** be in lowest adjustment position.
- Always lock casters when not moving evacuation crib.

Read all instructions **BEFORE** assembly and **USE** of evacuation frame kit. **KEEP INSTRUCTIONS FOR FUTURE REFERENCE.**

Carefully unpack carton and identify all parts.

Before each use or assembly, inspect all parts for damaged hardware, loose joints, missing parts, or sharp edges. **DO NOT** use evacuation frame if any parts are missing or damaged. For parts or assistance, call Foundations™ at 1-866-740-0195 (Monday - Friday, 9:00 a.m. - 4:00 p.m. Eastern Time).

TOOLS REQUIRED:

- PHILLIPS SCREWDRIVER (NOT INCLUDED)
- ADJUSTABLE WRENCH (NOT INCLUDED)

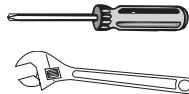

Division of Shamrock Industries, Inc.
7001 Wooster Pike
Medina, OH 44256
1-866-740-0195

PARTS LIST

Part Description	Qty.
A. End Frame	2
B. Side Rail	2
C. 3/8" Hex Nut, Zinc Plated	4
D. 3/8" Lock Washer, Zinc Plated	4
E. 1/4-20 x 3/4" Truss Head Phillips Machine Screw, Zinc Plated	8
F. 1/4-20 x 2" Truss Head Phillips Machine Screw, Zinc Plated	4
G. 1/4-20 Hex Nut, Zinc Plated	8
H. 1/4" Lock Washer, Zinc Plated	8
I. 1/4-20 Hex Nut with Nylon Insert	4
J. Locking Caster (has brake lever)	2
K. Non-locking Caster	2
L. 1/4" Flat Washer	4
M. Nylon Spacer	4

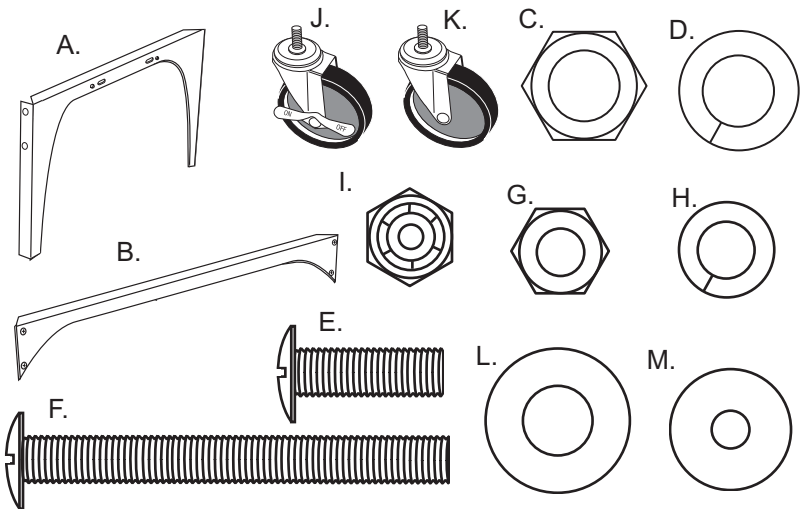

ONE YEAR LIMITED WARRANTY

Foundations™ warrants this product to be free from all defects in material and workmanship when used according to the manufacturer's instructions to the original owner for a period of one year from date of purchase. The warranty does not apply to damage caused by product alteration, normal wear and tear, misuse or abuse of the product. Keep your sales receipt as a record of the date of purchase. For replacement parts or warranty issues, please contact Foundations™ as we are better able to serve you. **DO NOT** return the product to your retailer or distributor.

If you need assistance, call or write:

Foundations™, 7001 Wooster Pike, Medina, OH 44256
Telephone 1-866-740-0195, Fax 1-330-721-6799

Frame Assembly

1. Place one **Side Rail (B)** inside the Leg of one **End Frame (A)** (Fig. 1), align holes in **End Frame (A)** with holes in **Side Rail (B)**.
2. Insert two **1/4-20 x 3/4" Machine Screws (E)** through holes in leg (Fig 2). Place a **1/4" Lock Washer (H)** and **1/4-20 Hex Nut (G)** on the end of each screw (E). **HAND TIGHTEN.**
3. Repeat Steps 1. and 2. to attach opposite **Side Rail (B)** to the same **End Frame (A)**.
4. Repeat Steps 1. through 3. to attach opposite **End Frame (A)** to the free ends of the **Side Rails (B)**.
5. Tighten all 8 **Screws** and **Hex Nuts** securely.
6. Turn Evacuation Frame upside-down. At both corners on a long side of frame, attach a **Locking Caster (J)** to each leg by inserting caster stem down through hole in bracket at bottom of Leg (Fig. 3). Secure with a **3/8" Lock Washer (D)** and a **3/8"-18 Hex Nut (C)**. Repeat to attach **2 Non-Locking Casters (K)** on corners of other long side of frame.
7. Tighten all 4 **Casters** and **Hex Nuts** securely.

Frame assembly is now complete and ready to attach to crib.

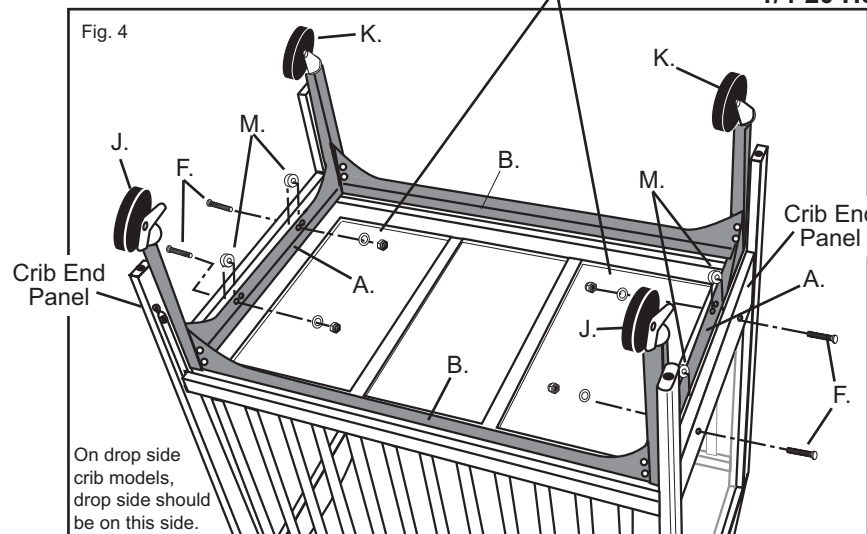
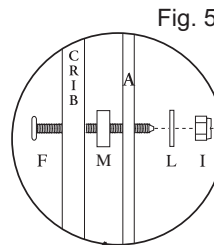
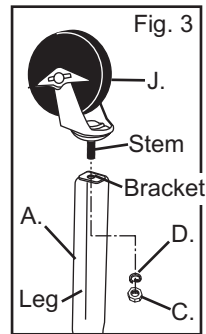
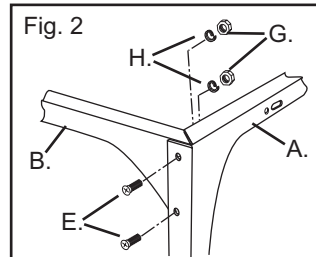
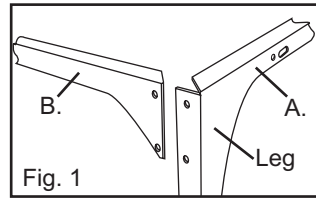

Assembly To Crib

(This step is easier to do using two people.)

1. If the crib has an adjustable **Mattress Support**, set **Mattress Support** in its lowest position.
2. Turn the crib upside-down on a smooth surface. To keep the crib from rocking as you work, put a book or other item under each side of one crib **End Panel**.
NOTE: If adding evacuation frame to an assembled crib with casters, remove crib casters.
3. Turn **Frame Assembly** upside-down and carefully place on the underside of the **Mattress Support** (Fig. 4). **NOTE:** On **Drop Side** crib models, the **Locking Casters** of the **Frame** should be positioned on the same side as the **Drop Side** of the crib.
4. On one end of the crib, align two holes in the **Frame** with the holes in the **Bottom End Rail** of crib **End Panel**.
- For **Drop Side** crib models, position the **Frame** **closer to the Stationary Side**. This will ensure that the **Drop Side** will still operate after the **Frame** is attached.
- For **Stationary Side** crib models, either set of holes may be used.
- Be sure frame is attached straight on crib and does not protrude outside crib legs.
5. From outside of the end panel, insert two **1/4-20 x 2" Machine Screws (F)** through holes in **Bottom End Rail** of **Crib End Panel** and through two **Nylon Spacers (M)**. Be sure to place the **Nylon Spacer (M)** between the **Frame End (A)** and the **Crib Bottom End Rail** (Fig. 5). **NOTE:** All four spacers may not be needed. **DO NOT** force spacers into space between frame and **Bottom End Rail**.
6. Insert the **Machine Screws** into the corresponding holes in the **Evacuation Frame End (A)** (Fig. 4). On the end of each **Machine Screw (F)**, place a **1/4" Flat Washer (L)** and a **1/4-20 Hex Nut with Nylon Insert (I)**, **DO NOT Tighten.**

7. Repeat Steps 2 and 6 for the other end of the Crib.
8. Securely tighten all 4 **Machine Screws** and **Hex Nuts with Nylon Insert** on both ends of the crib.
9. Carefully turn the **Evacuation Crib** to its upright position.

The **Evacuation Crib** is now ready for use.