



Shower Column SHCM-2648-00 Installation Guide



I. Parts List:



| | | | | | |
|-------------|---|------|----|--|------|
| 1. | Shower arm | 1 pc | 14 | 59" flexible shower hose kit | 1pc |
| 2,13, 19 | Rubber washer (used together with parts# 3,14,20) | 3pcs | 15 | Mounting bracket | 2pcs |
| 3 | Showerhead | 1pc | 16 | Arm mounting screws | 2pcs |
| 5 | Wall anchors | 4pcs | 18 | Nuts | 2pcs |
| 6, 17 | Stainless steel washer | 6pcs | 20 | L-Fitting | 1pc |
| 8, 9 | Water Supply Hoses | 2pcs | 21 | Corner mounting bracket (used for corner installation) | 2pcs |
| 12 | Hand Shower | 1pc | | | |

II. Preparation

1. After opening the box, read this introduction carefully, check all the packed parts are complete by cross checking of all the components. Examine for shipping damage. If the unit has been damaged or has a finishing defect, please contact your local distributor within 2 business days. Please note that **Bath Authority™ / DreamLine™ will not replace any damaged product or parts free of charge, ONCE the product has been installed.** Your distributor's responsibility for damage in transit is limited after the shower package has been transferred to the transportation company, so you may have to contact the transportation company directly to report damage. Contact your distributor or DreamLine if you have any questions.
2. You should consult your local building codes on questions on installation compliance standards. Install all of the required plumbing. Your plumber will need to supply with two ½" male threaded pipes for hot and cold water outlets. **Use a competent and licensed (if required by local code) plumber for all plumbing installation.**
3. Please, note that there are some adjustments and drilling might be necessary during the installation process.

III. Technical specifications

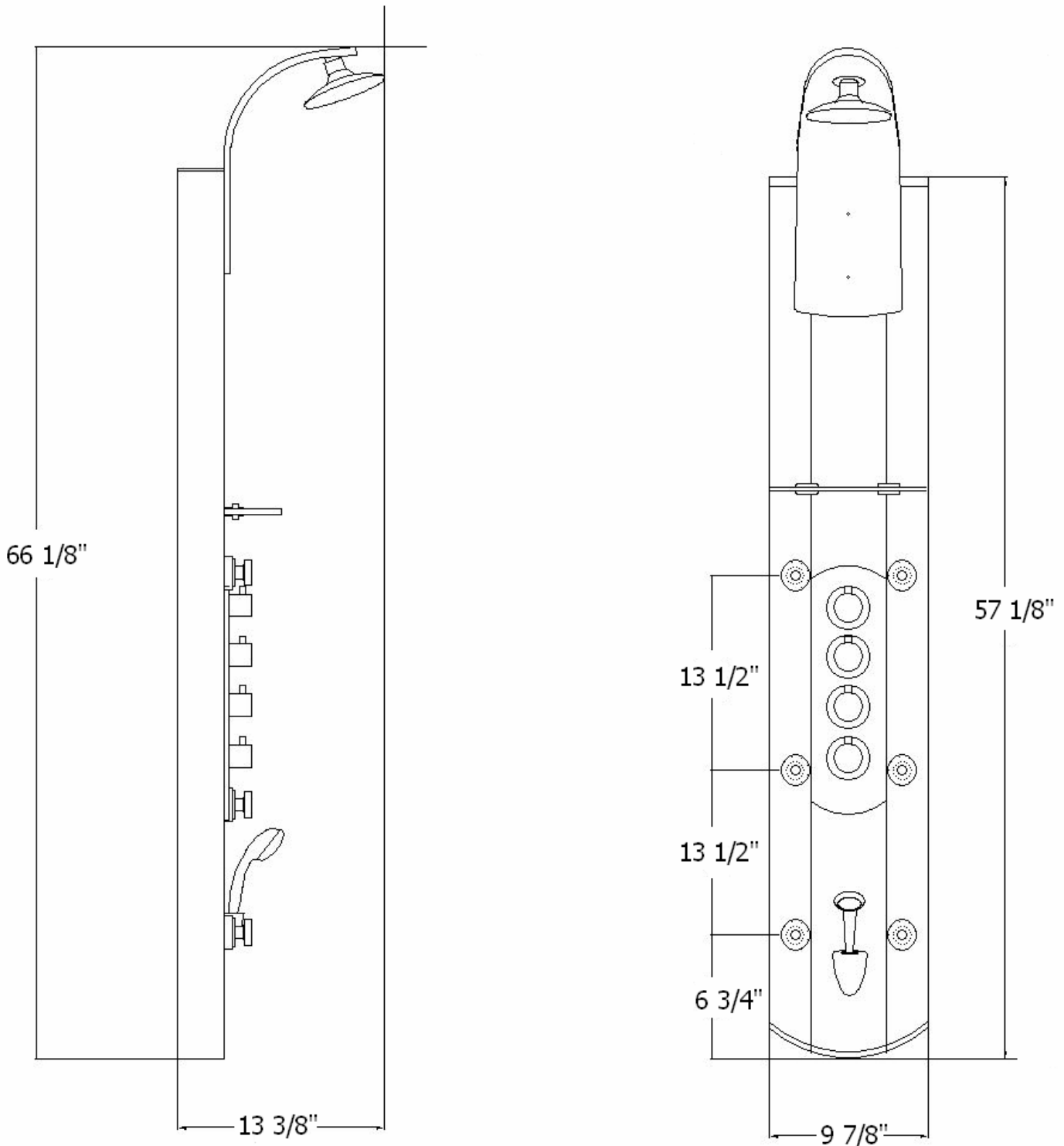

Technical Diagram

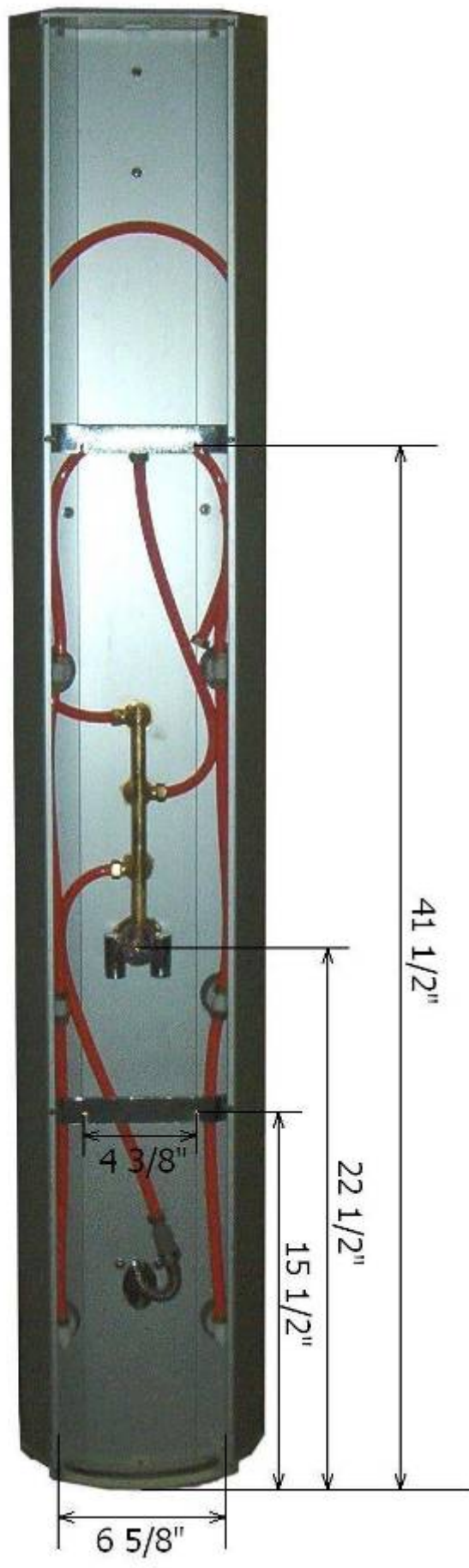

IV. Installation procedure

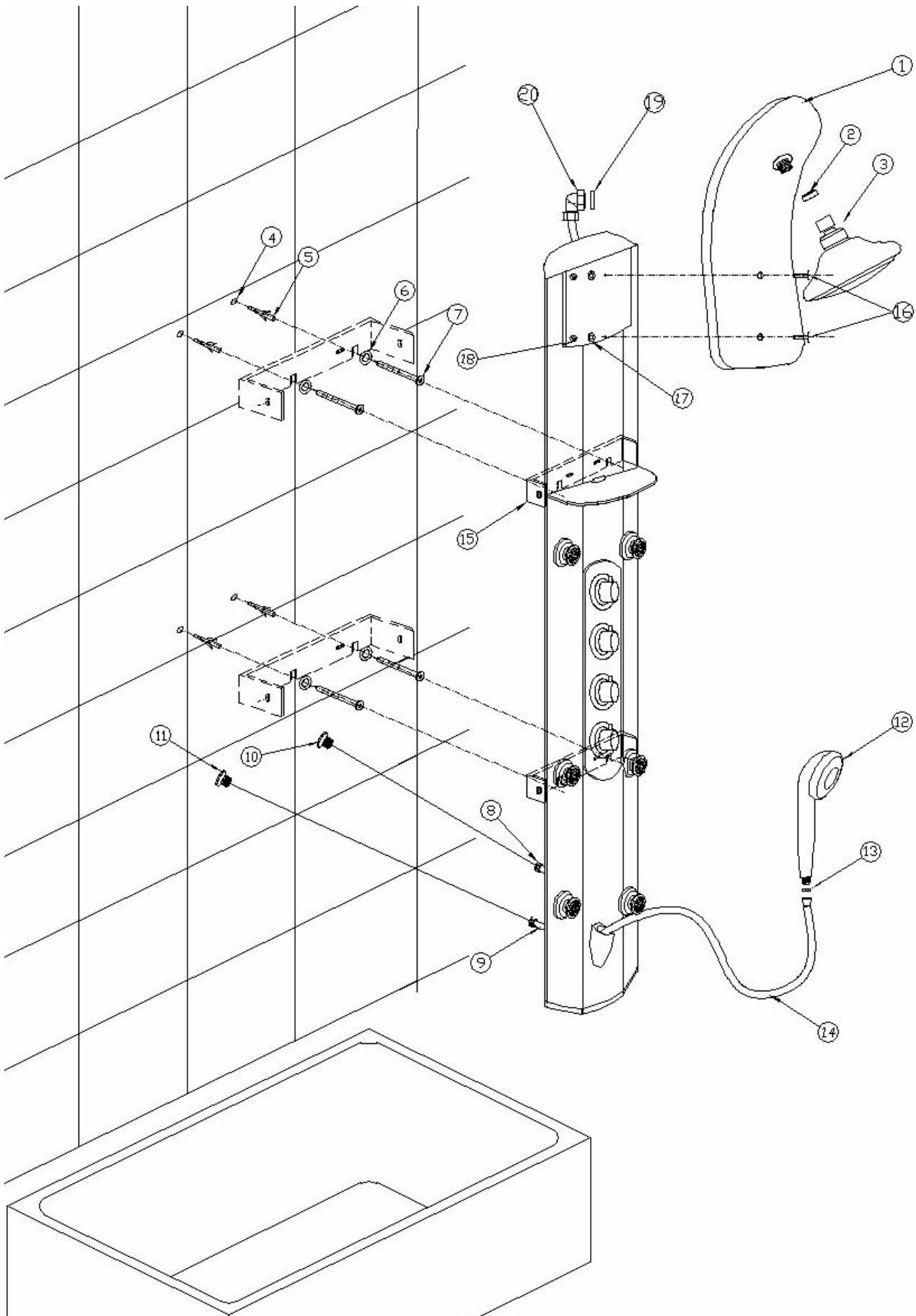

Refer to the technical diagram to choose the proper location for your shower column. You can adjust the column's vertical position based on the person's height. (Measurements given in the technical diagram are based on the average human height – 68"-70").

1. Secure the shower arm (1) on to the column using screws (16), washers (17) and nuts (18).
2. Place gasket (19) into L-fitting (20).
3. Connect L-fitting (20) with Shower arm water supply fitting (1).
4. Place rubber washer (2) into the Shower head (3).
5. Connect the Shower head (3) to the Shower arm (1).
6. Choose the proper location for your column and mark the drill holes (4). Drill the holes on the distance 4 ¼" from each other.
7. Insert Wall anchors (5) inside the holes.
8. Tighten the screws (7) to the wall with stainless steel washers (6). Leave the screw heads ¼" from the wall.
9. Connect the flexible hot (8) and cold (9) water supply lines to hot (10) and cold (11) water outlets (supplied by your plumber) accordingly.
10. Hang the Mounting bracket (15) on the screws (7) secured in the wall.
11. Connect the hand shower head (12) to the hose (14) placing the rubber washer (13) in the fastening nut.

Corner installation.

For Corner installation you need to install Corner mounting bracket (25). Refer to the technical diagram to choose the proper location for your shower column. You can adjust the column's vertical position based on the person's height. (Measurements given in the technical diagram are based on the average human height – 68"-70").

6. Choose the proper location for your column and mark the drill holes (4). Drill the holes on the distance 2 ¼" from corner.
7. Insert Wall anchors (5) inside the holes.
8. Attach Corner mounting bracket to the wall using screws (7) with stainless steel washers (6).

The rest of the installation procedure is the same as flat wall mounting.

Please, make sure that none of the hoses are bent or kinked after final installation. Check water connections for proper flow; make sure there is no leakage.

Our product may have changes without prior notice

For the latest manual version, please, check online www.bathauthority.com

Bath Authority™ LLC / DreamLine™

Shower Enclosure, Jetted/Steam Shower and Shower Columns

Limited Warranty

CONSUMER RESPONSIBILITIES

Your DreamLine™ Shower Products will remain beautiful for many years if you take care of them. Some of the waterproofing plastic strips and other seals will need to be replaced when they show signs of wear, yellowing, or are not watertight. Refer to the parts list of your manual for all seals. Water conditions in various parts of the country will determine any extra cleaning attention you may have to give your new shower enclosure or jetted shower. DreamLine™ does not recommend the use of harsh abrasive cleansers on any of its products. Harsh cleansers will damage the metal or glass finish on your shower enclosure or jetted shower.

REQUESTING SERVICE

Here's what you need to do if you require service:

1. Contact the dealer who sold and/or installed the product. They should be able to solve any problems you may have.
2. If your dealer or contractor cannot solve the problem, they will contact or supply you with the name of the local DreamLine™ Distributor or a DreamLine™ Direct Technical Specialist
3. If you are unable to obtain warranty service through either your contractor or DreamLine™ distributor, please write us directly at

Bath Authority™ LLC / DreamLine™
909 Louis Drive
Warminster, PA 18974
ATTN: Customer Service Department

4. Include all pertinent information regarding your claim, including a complete description of the product, model numbers, colors, finishes, and the date the product was installed. Include a description of the problem and a photocopy of your invoice and purchase receipt(s) for the products involved. Also please provide information on the name and contact telephone numbers of the contractor and distributor.

Please note that under any circumstances, DreamLine™ products should not be returned to your dealer, distributor or directly to DreamLine™ without a written Return Merchandise Authorization (RMA).

LIMITED ONE-YEAR WARRANTY

This warrantee extends only to the original owner/end-user for personal household use only. For commercial uses, additional limitations may apply.

DreamLine™ warrants acrylic surface against blistering or cracking and chipping resulting from defect in the acrylic surface material when used under normal condition and service for a period of one (1) year from the purchase date.

DreamLine™ warrants mirrors, shower doors, shower massage systems, faucet finishes and fittings to be free from defects in workmanship and materials under normal use and service for a period of one (1) year.

DreamLine™ further warrants the structure of the acrylic shell against loss of water through the fiberglass laminate of the acrylic body as a result of defect in materials and workmanship for a period of five (5) years from the purchase date.

DreamLine™ will, at its election, repair, replace, or make appropriate credit adjustment where DreamLine™ optional inspection discloses any such defects occurring in normal usage within the warrantee periods. **Please note that DreamLine™ is not responsible for any installation or removal costs.**

Improper modification of any enclosure, jetted shower or shower column components may void the warrantee - so please install the product as directed in the manual. This warrantee does not cover any claim arising from abuse, misuse, negligence, accident, improper installation or operations on the part of the purchaser. This warrantee is void if the DreamLine™ product is subject to alterations, or if repairs are attempted by anyone other than an authorized agent of DreamLine™. This warrantee does not extend to any plumbing or components installed by dealers, installers or by any party other than DreamLine™.

Implied warranties, including that of merchantability or fitness for a particular purpose, are expressly limited in duration to the duration of this warranty. DreamLine™ disclaims any liability for special, incidental, or consequential damages.

Some states do not allow limitations on how long an implied warranty lasts or the exclusion or limitation of special, incidental, or consequential damages, so these limitations and exclusions may not apply to you. This warranty gives you specific legal rights. You may also have other rights which vary from state to state. This limited warranty provides specific legal rights as they apply within the USA, and other rights may be available, but may vary from country to country.

This is our exclusive written warranty for DreamLine™ Shower Enclosure, Jetted/Steam Shower and Shower Column purchases made after May 2004. DreamLine™ reserves the right to modify this warranty at any time; and the consumer understands that such modification will not alter the warranty conditions applicable at the time of the sale of the product.