

TWO HANDLE CENTERSET LAVATORY FAUCET

Description

- 2 handle with all brass pop-up drain assembly

Flow & Valving

- See Chart

Standards

- ASME A112.18.1
- CSA B125
- NSF 61-9
- Energy policy act of 1992
- Listed IAPMO/UPC
- ADA Accessibility Guidelines for Buildings and Facilities - 4.27.4 Controls and Mechanisms 

Warranty

Danze products are covered by a manufacturer's limited "lifetime" warranty for manufacturing defects.



D305258
PARMA™



Available Colors & Finish

- Chrome
- Brushed Nickel (BN)

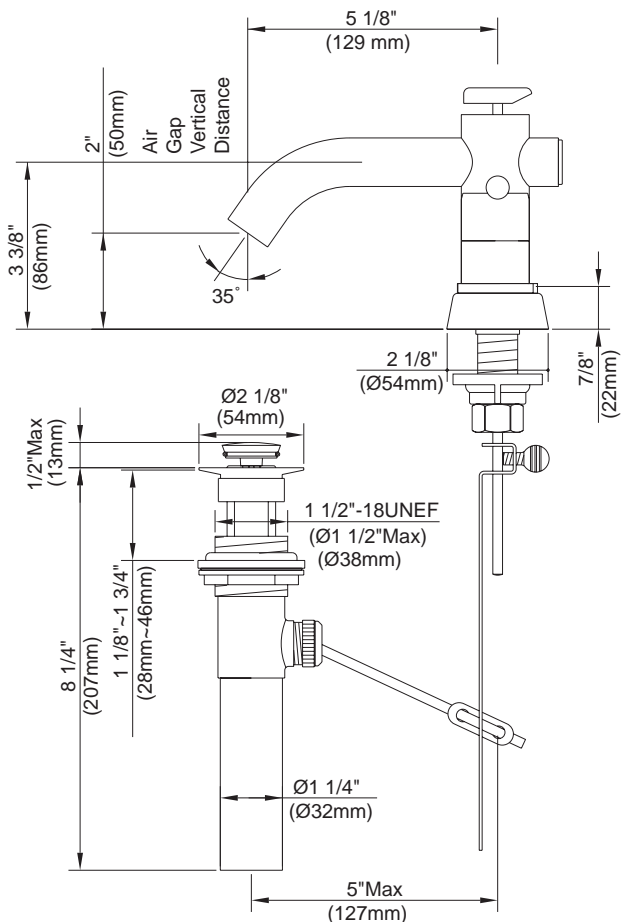
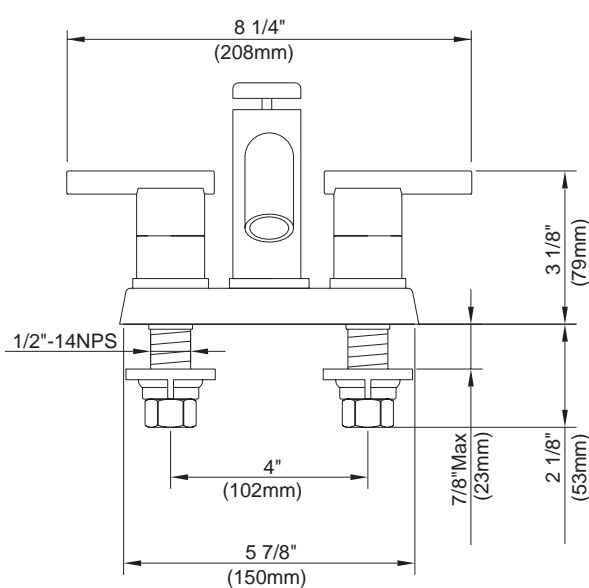
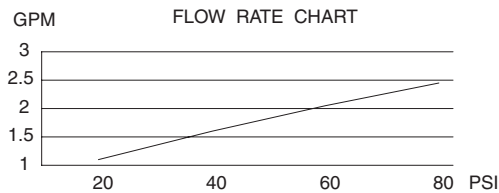

Specific Features: _____ Submitted Model No.: _____

SD305258/03-06.01