

Instructions for Original Black Forest Cuckoo Clock

Read instructions carefully before assembly, following picture illustrations.

- Carefully remove clock and parts from carton, unwrap loose accessories.

Verify parts — pendulum
 — top piece (not on chalet clocks)
 — weights
 — stag head
 (only with top pieces crest style)

- Put clock face down

ill. 1

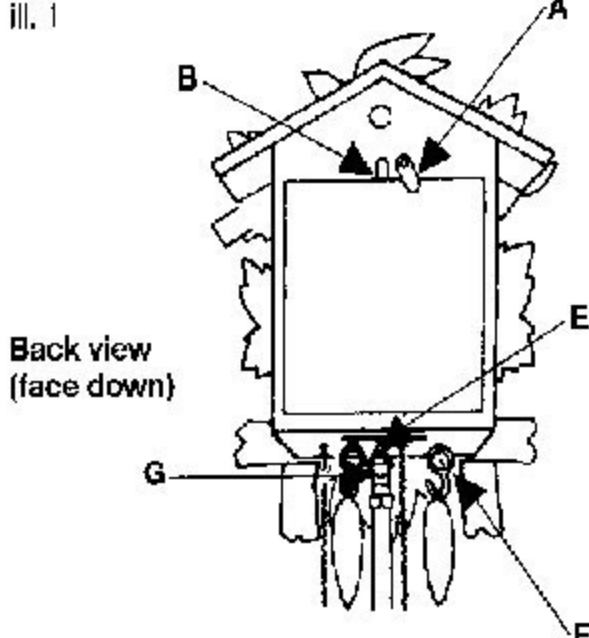

- Push clamp (A) to side (if 2 clamps slide both to side). Open back panel with screw driver in slot (B). Remove back. Do not remove small bag under clock (G).
- Carefully remove paper under chime spring on inside of back panel.
- Remove wire clips (C) from the bellows (caution they are delicate). ill. 2.

ill. 2

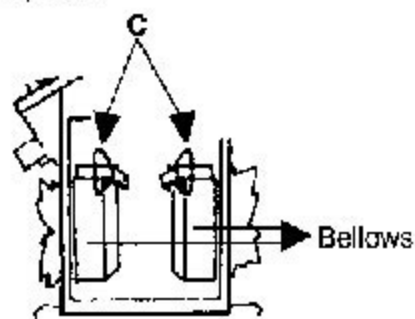

- Take care not to bend or damage any wires. Put back the panel and close case.
- Secure panel by re-closing clamp (or clamps) so that panel cannot come off.
- Turn clock and fasten carved top piece on front (not on chalet clocks).

- Mount securely to wall using a nail or screw that will be strong enough to hold clock.

Note:

Clock must not be tipped forward or to one side, it must be level so the pendulum can swing freely.

- Carefully unwrap chains from paper bag under clock and completely remove paper and wire. Do not turn clock upside down at any time after removing this wire. Chains should hang freely through the bottom of the clock. ill. 3.

- Release door (or doors) of the cuckoo bird by pushing the little wire bolt (or bolts) (D) to the side ill. 3, so that the door (doors) can be opened.

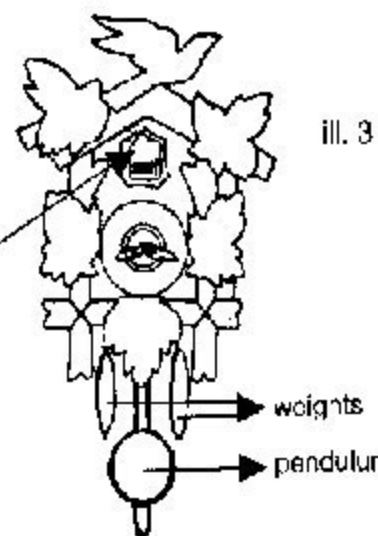

- Hang pendulum on triangular wire loop (E) and pine cone weights on the hooks (F) (ill. 1). Clock might now start to cuckoo; do not try to stop this. The striking mechanism is self adjusting and will strike properly after first hour.

- To set correct time; slowly turn the minute hand (longer hand) forward or backward until correct time is shown. Do not touch the hour hand (small hand).

- To start the clock, gently push the pendulum to one side. Take care that the clock hangs absolutely straight by listening to the regular and evenly paced „tick-tack“.

- Your clock comes to you fully wound. Notice after a few hours the pine cones have lowered and the rings of the chains have raised. (Pine cone weights will not go down together). To rewind; simply pull the rings down until the pine cones come up under the clock to their fully wound position.

- To set correct time; slowly turn the minute hand (longer hand) forward or backward until correct time is shown. Do not touch the hour hand (small hand).

- To start the clock, gently push the pendulum to one side. Take care that the clock hangs absolutely straight by listening to the regular and evenly paced „tick-tack“.

- Your clock comes to you fully wound. Notice after a few hours the pine cones have lowered and the rings of the chains have raised. (Pine cone weights will not go down together). To rewind; simply pull the rings down until the pine cones come up under the clock to their fully wound position.

- If the clock loses time, move the disk on the pendulum rod up, if the clock gains time, move it down. ill. 4.

ill. 4

