

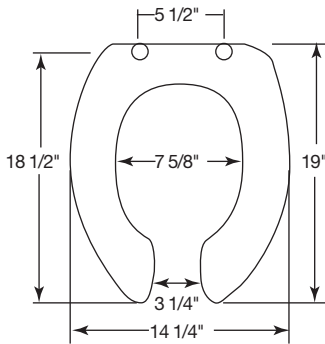

## COMMERCIAL PLASTIC SEATS

### MODEL 9500C

- ELONGATED SEAT, OPEN FRONT LESS COVER
- SOLID PLASTIC
- CONCEALED CHECK STAINLESS STEEL HINGES



Ring thickness is 1"

Ring thickness including the bumper is 1-3/16"

Seats shall be No. \_\_\_\_\_ as manufactured by Church Seats. Seats shall be extra heavy weight and injection molded of solid plastic. Seats shall be open front less cover for elongated bowl and feature large molded-in bumpers. Concealed check hinges to feature 300 Series stainless steel posts that stop seat 11 degrees beyond vertical. Uses 300 Series stainless steel hardware. Color to be \_\_\_\_\_. (specify white or fixture manufacturer's color) Hinges shall be \_\_\_\_\_. (specify hinge type)

**9500C** Concealed check hinge stops seat 11° beyond vertical.

**9500SSC** Self-sustaining, concealed stainless steel check hinge holds seat in any raised position up to 11° beyond vertical.

**\*\* ANSI Z124.5 section 5.1.2 Tests have shown that this product will support weights up to 500 pounds.\*\* (Contact Church Seat Co., for test data)**

