

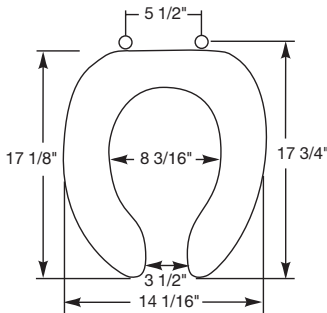

# COMMERCIAL PLASTIC SEATS

## MODEL 290TL

- ELONGATED SEAT, OPEN FRONT WITH COVER
- SOLID PLASTIC
- HINGES WITH NON-CORROSIVE TOP-TIGHTENING BOLTS, WING NUTS AND NO-SLIP WASHERS



Seats shall be No. 290TL as manufactured by Church Seats. Seats shall be heavy weight and injection molded of solid plastic. Seats shall be open front with cover for elongated bowl and feature large molded-in bumpers. Color-matched hinges contain stainless steel pintles and non-corrosive top-tightening bolt, wing nut and no-slip washers. The “locked-in” hinge design will prevent wobbling. The molded-in bumpers provide easy cleaning. Color to be white.

Ring thickness is 3/4"  
Ring thickness including the bumper is 1-1/16"  
Height of the seat with cover is 2-1/4"

