

---

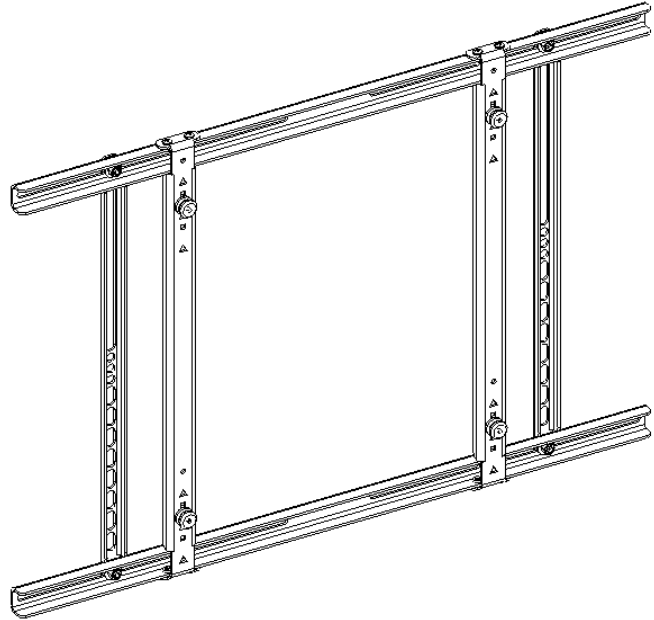
# INSTALLATION INSTRUCTIONS

---

## Model PSB-2000

## Universal Flat Panel Display Wall Mount Brackets

The Model PSB-2000 is a versatile mounting solution for Large Flat Panel displays for business, home theater and commercial applications. Display mounting is made simple, safe, and secure.



### BEFORE YOU BEGIN

- **CAUTION:** To prevent damage to the mount, which could affect or void the Factory warranty, thoroughly study all instructions and illustrations before you begin to install the mount brackets. Pay particular attention to the “Important Precautions” on Page 1.
- If you have any questions about this installation, contact Chief Manufacturing at 1-800-582-6480 or 952-582-6480.



## IMPORTANT WARNINGS and CAUTIONS!

- WARNING**      **A WARNING alerts you to the possibility of serious injury or death if you do not follow the instructions.**
- CAUTION**      **A CAUTION alerts you to the possibility of damage or destruction of equipment if you do not follow the corresponding instructions.**
- **WARNING:**      **Improper installation can result in serious personal injury! Make sure that the mounting surface structural members can support a redundant weight factor *five times* the total weight of the equipment: if not, reinforce the mounting surface structural members before installing the mount.**
  - **WARNING:**      **You must use proper attaching hardware and installation procedures. Failure to use proper attaching hardware and installation procedures may result in equipment damage or serious personal injury.**
  - **WARNING:**      **Be aware of the potential for personal injury or damage to the unit if it is not adequately mounted.**
  - **WARNING:**      **The installer is responsible for verifying that the mounting surface structural members to which the mount is anchored will safely support the combined load of all attached components or other equipment.**
  - **WARNING:**      **The combined weight of the display panel must not exceed the maximum load capacity of the mount.**
  - **CAUTION**      **Check the unit for shipping damage before you begin the installation.**
  - **CAUTION**      **Overtightening mounting screws may damage your Large Flat Panel display.**

## TOOLS REQUIRED FOR INSTALLATION

- Phillips screwdrivers, No. 1 and No. 2
- Socket set

**NOTE:** Other tools may be required depending on the method of installation.

## CONTENTS

TOOLS REQUIRED FOR INSTALLATION..... 2

PARTS ..... 3

INSPECT THE BRACKET BEFORE INSTALLING ..... 4

BRACKET INSTALLATION..... 5

# PARTS

**Table 1. Parts List**

Item	Description	Qty	Item	Description	Qty
10	Side Bracket	2	Bag E	Flat Washer, #10	8
20	Horizontal Bracket	2		Shoulder Washer, .195 ID	8
30	Mounting Button Bracket	2	Bag F	Flat Washer, 1/4"	8
Bag A	Phillips Head Cap Screw, M8 X 20mm	6		Shoulder Washer, .32 ID	8
	Phillips Head Cap Screw, M8 X 30mm	8	Bag G	Washer, Nylon, .25 Thick	8
	Phillips Head Cap Screw, M8 X 45mm	8		Washer, Nylon, .5 Thick	8
Bag B	Phillips Head Cap Screw, M6 X 16mm	6	Bag I	Mounting Button - Threaded	4
	Phillips Head Cap Screw, M6 X 25mm	6		Button Head Cap Screw, 10-24 x .5"	4
Bag C	Phillips Head Cap Screw, M5 X 16mm	8		Allen Key, 1/8"	1
	Phillips Head Cap Screw, M5 X 20mm	8	Bag J	Phillips Head Cap Screw, 10-24 x .375"	8
	Phillips Head Cap Screw, M5 X 25mm	8	Bag K	Flat Washer, 1/4"	4
Bag D	Phillips Head Cap Screw, M4 X 16mm	8		Nylock Nut, 1/4"-20	4
	Phillips Head Cap Screw, M4 X 20mm	8			
	Phillips Head Cap Screw, M4 X 25mm	8			

## INSPECT THE BRACKET BEFORE INSTALLING

1. Carefully inspect the interface brackets (see Figure 1. Interface Brackets and Table 1. Parts List on page 2) for shipping damage. If any damage is apparent, call your carrier agent and do not continue with the installation until the carrier has reviewed the damage.

**NOTE: Read all assembly instructions before starting assembly.**

2. Carefully inspect all parts bags to ensure all components are in each bag. If any components are missing, contact Chief Manufacturing at 1-800-582-6480 or 952-582-6480

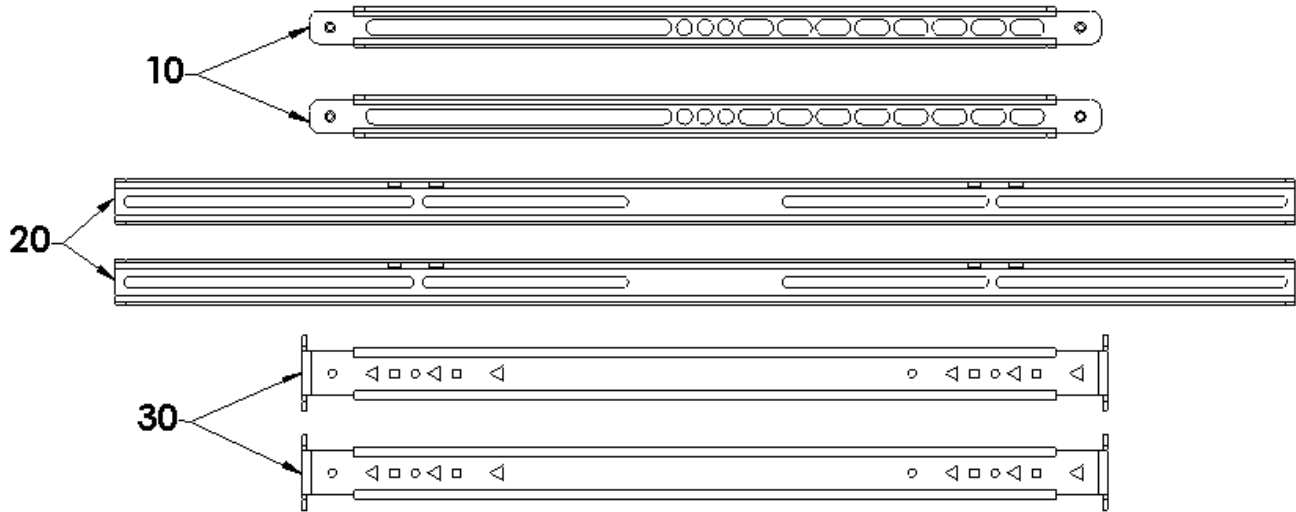


Figure 1. Interface Brackets

# BRACKET INSTALLATION

Install the brackets as follows:

1. For recessed mounting hole applications, place spacers (Bag G) over mounting holes of display as necessary.
2. Lay the side brackets (10) over the mounting holes on the back of the display (see Figure 2), making sure to vertically center side brackets as much as possible.

**WARNING:**

**You must use proper attaching hardware and installation procedures. Failure to use proper attaching hardware and installation procedures may result in equipment damage or serious personal injury.**

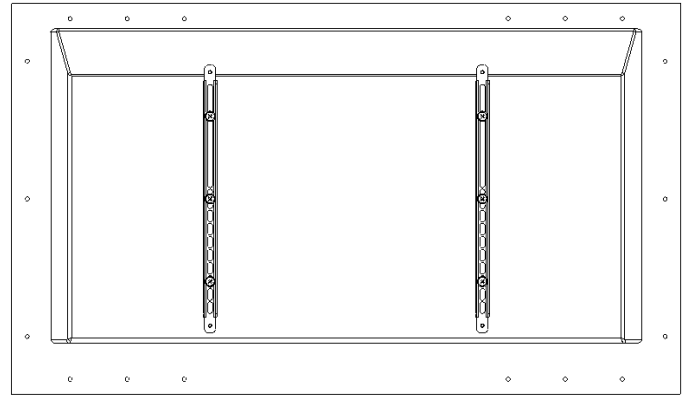
3. Use center holes in brackets to assist centering if applicable.

**NOTE:**

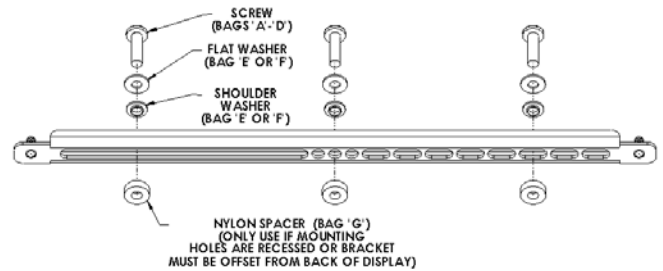
Use the top of the slots to prevent the brackets from sliding.

4. Install side brackets (10) using Nylon shoulder washers, steel washers (Bags E or F) and Phillips screws (Bags A through D) – (see Figure 3). Install the attaching hardware snug but not tight.
5. Install horizontal brackets (20) on side brackets (10) and secure loosely using four flat washers and four Nylock nuts (Bag K). See Figure 4.

**ATTACH SIDE BRACKETS TO BACK OF DISPLAY. CENTER (VERTICALLY) BRACKETS AS BEST AS POSSIBLE.**

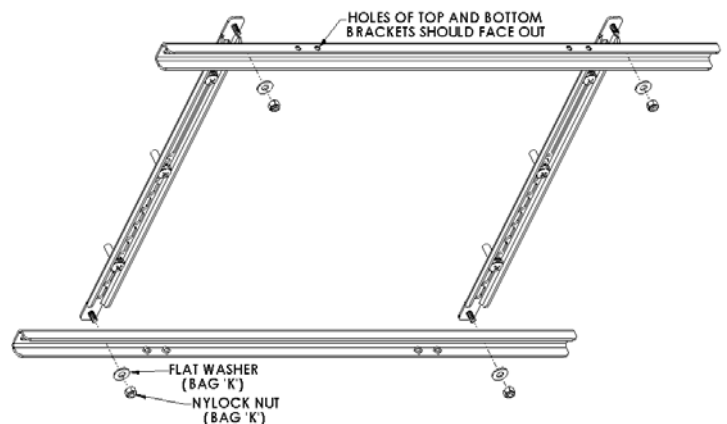


**Figure 2. Lay Out Side Brackets**



**USE PROPER LENGTH, SIZE AND AMOUNT OF SCREWS/WASHERS DEPENDING ON DISPLAY MOUNTING HOLE PATTERN**

**Figure 3. Use Center Hole If Applicable**



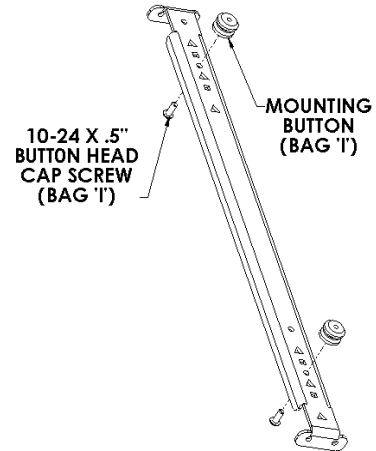
**Figure 4. Secure Horizontal Brackets**

- Lay the mounting button brackets (30) on the horizontal brackets (20) and determine which holes to use to center the mounting buttons (Bag I).

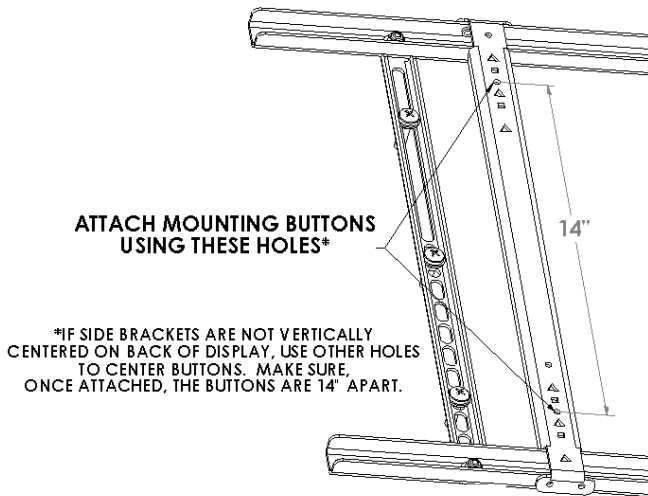
**NOTE:**

Select the round holes, square holes, or triangle holes to install the mounting buttons. Do not install the brackets using unmatched holes.

- As shown in Figure 5, attach mounting buttons on bracket (30) in a 14" pattern using four button head cap screws (Bag I). See Figure 6.
- Install mounting button brackets (30) using eight Phillips screws (Bag J). See Figure 7.
- Make sure brackets are centered on the display and tighten all fasteners. See Figure 8.



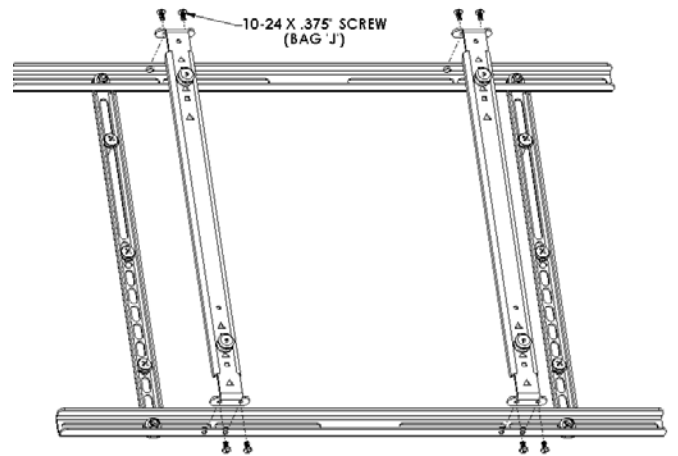
**Figure 6. Mounting Button Locations**



**ATTACH MOUNTING BUTTONS USING THESE HOLES\***

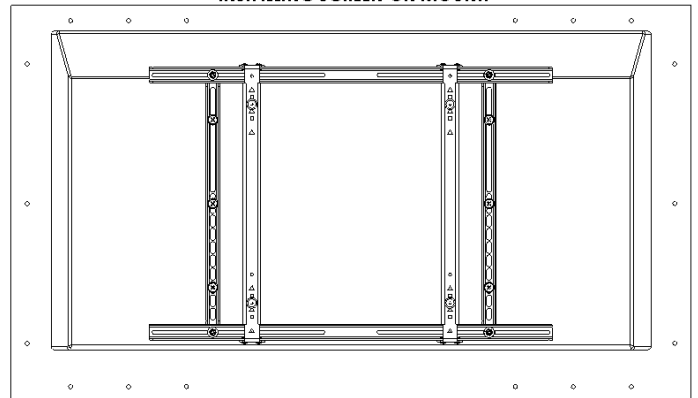
\*IF SIDE BRACKETS ARE NOT VERTICALLY CENTERED ON BACK OF DISPLAY, USE OTHER HOLES TO CENTER BUTTONS. MAKE SURE, ONCE ATTACHED, THE BUTTONS ARE 14" APART.

**Figure 5. Install Mounting Buttons**



**Figure 7. Install Mounting Button**

**MAKE ANY ADJUSTMENTS NEEDED TO GET 14" X 14" BUTTON PATTERN CENTERED (VERTICALLY AND HORIZONTALLY) ON BACK OF SCREEN. TIGHTEN ALL SCREWS OR NUTS BEFORE INSTALLING SCREEN ON MOUNT.**



**Figure 8. Center Bracket and Secure**