

INSTALLATION INSTRUCTIONS

BOLT DOWN CENTER BASE ASSEMBLY PAC-146

The PAC-146 accessory is designed for use with the Chief dual post floor stand.

WARNING: IMPROPER INSTALLATION MAY RESULT IN SERIOUS PERSONAL INJURY!

When mounting Chief Manufacturing accessories, the structural system and mounting method **MUST** be capable of supporting 5 times the combined weight of the total installation. The total weight placed on the floor stand must not exceed 300 pounds (136.1 Kg).

Unpack and check contents:

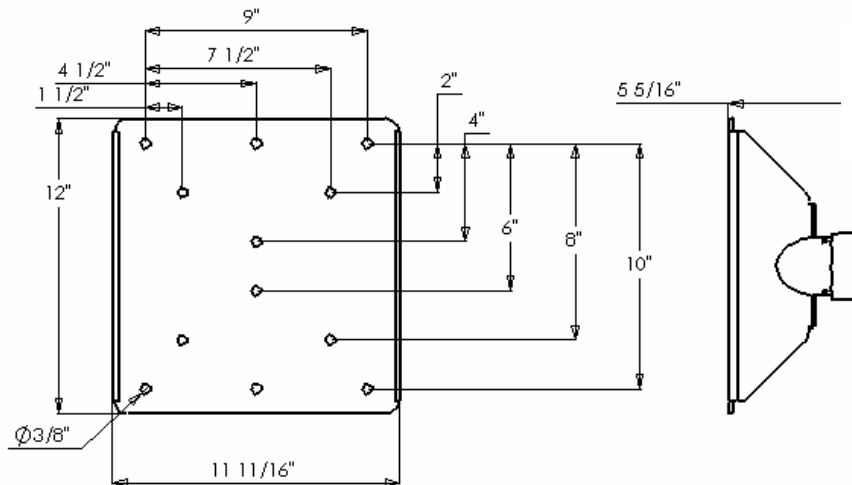

Figure 1. Base Dimensions

- | | |
|-----------|---------------------------------|
| (1) BASE | (4) SCREW, Set, 5/16-18 |
| (2) COVER | (4) SCREW, Phillips Head, 10-24 |

INSTALLATION INSTRUCTIONS

BEFORE PROCEEDING, READ INSTALLATION INSTRUCTIONS COMPLETELY

1. Remove four screws securing covers and remove covers (see Figure 2).

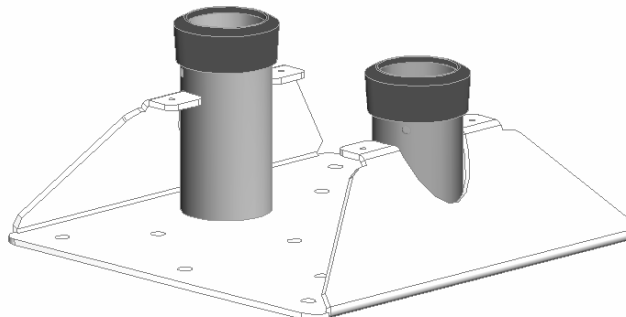

Figure 2. Remove Covers



CHIEF MANUFACTURING INC.
1-800-582-6480 952-894-6280 FAX 952-894-6918
12800 HIGHWAY 13 SOUTH, SUITE 500
SAVAGE, MINNESOTA 55378 USA

8800-000023
2003 Chief Manufacturing
www.chiefmfg.com
12/03

2. Place base at desired location, ensuring location is flat and capable of supporting five times the combined weight of the stand and all equipment mounted on the stand
3. Using the base as a template, mark anchor locations.
4. Remove base, drill and install anchors, and place base over anchors
5. Secure base at desired location, ensuring base is sufficiently anchored to support the weight of all attached equipment.
6. Install covers and secure using four screws (see Figure 4).
7. Install upright tubes into base (see Figure 4).
8. Insert setscrews in base and tighten to secure upright tubes (see Figure 5).

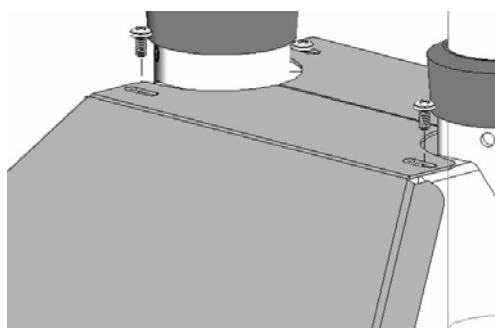

Figure 3. Install Covers

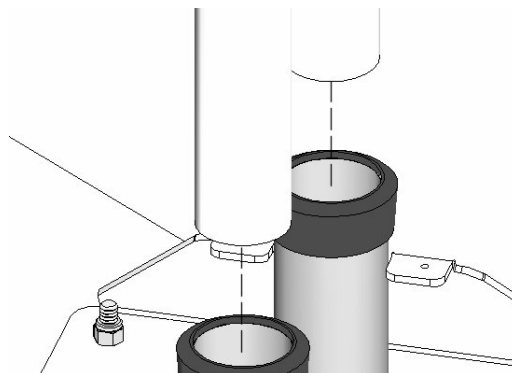

Figure 4. Install Tubes

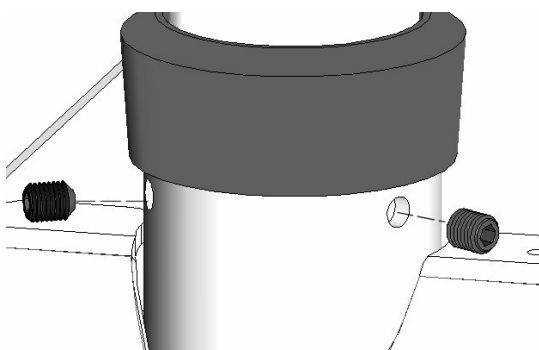

Figure 5. Insert Setscrews