

INSTALLATION INSTRUCTIONS

Single Sided Base Assembly (PAC-145)

The PAC-145 Single Sided Base assembly is compatible with the dual pole floor stand and other products and accessories offered by Chief.

PARTS LIST

Unpack the shipping carton and check for the contents listed in Table 1 and shown in Figure 1.

Table 1. Parts List

REF	DESCRIPTION	QTY	REF	DESCRIPTION	QTY
10	BASE WELDMENT	1	60	SCREW, 10-24 x 3/8" Phillips head	4
20	PLATE, single base, front	1	70	SETSCREW, 5/16-18 x 3/8"	4
30	PLATE, single base, back	1	80	NUT, Nylock, 3/8-16	8
40	COVER	2	90	KEY, Allen, 5/32"	1
50	SCREW, 3/8-16 x 1" cap, flat head	8	100	KEY, Allen, 7/32"	1

PARTS

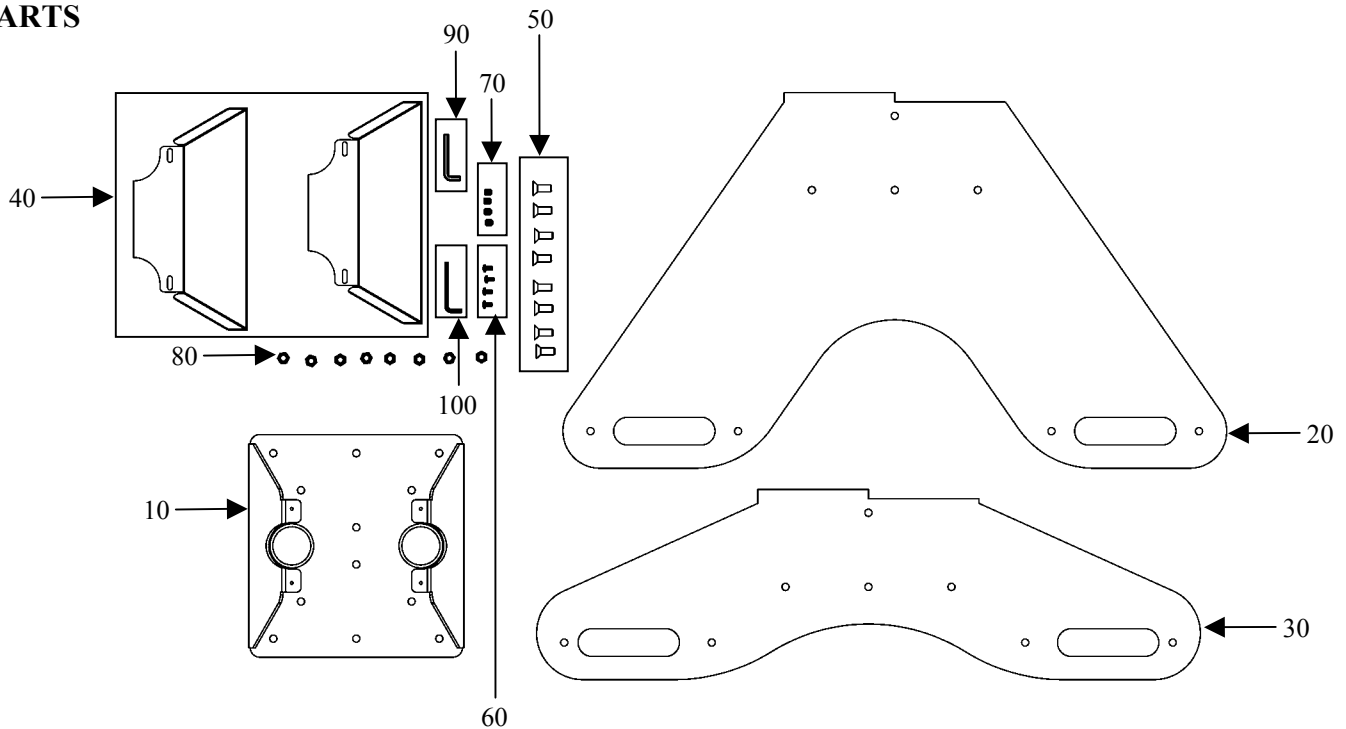

Figure 1. Parts

TOOLS REQUIRED FOR INSTALLATION

- 5/32" Allen wrench (provided)
- Phillips screwdriver

WARNING

IMPROPER INSTALLATION MAY RESULT IN SERIOUS PERSONAL INJURY! When mounting Chief Manufacturing accessories, the structural system and mounting method *must* be capable of supporting 5 times the combined weight of the total installation. The total weight placed on the floor stand must not exceed 300 lbs. (136.1 kg).

INSTALLATION

Assemble the PAC-145

To assemble the base, do the following:

1. With the front plate (20) and back plate (30) turned upside down, align the two plates together as shown in Figure 2.
2. Attach the base (10) to the front plate (20) and back plate (30) using eight flat head screws (50) and eight Nylock nuts (80). See Figure 2.

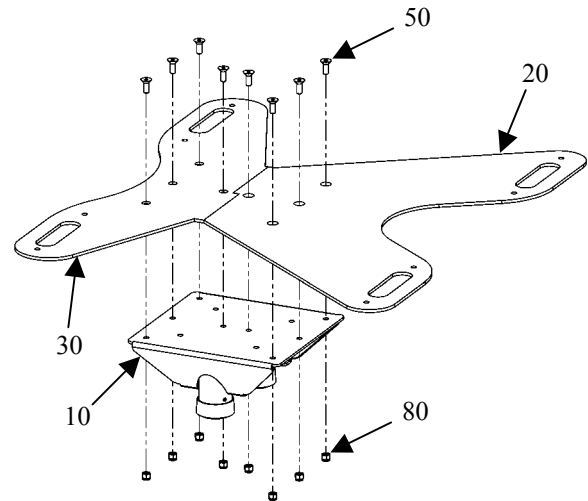

Figure 2. Assemble the Base

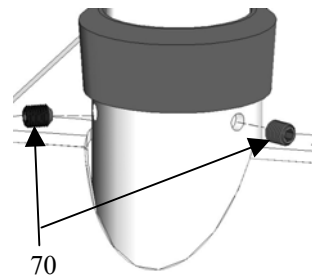

Figure 3. Install Set Screws

Attach Dual Poles to PAC-145

To attach dual poles to PAC-145, do the following:

1. With the base assembly turned right side up, install four 5/16-18 x 3/8 socket head set screws (70) into the PAC-145. See Figure 4.
2. Install the dual poles (not provided) into the mounting holes on the PAC-145 (see Figure 4).
3. Tighten the four set screws (70).
4. Install two base covers (40) using four 10-24 x 3/8" Phillips screws (60). See Figure 5.

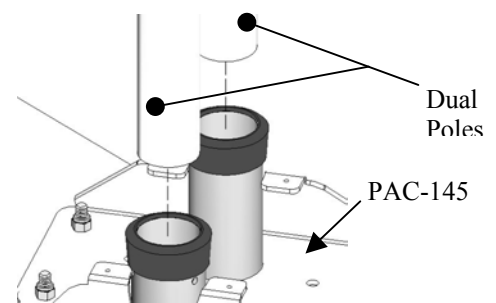

Figure 4. Install Dual Poles

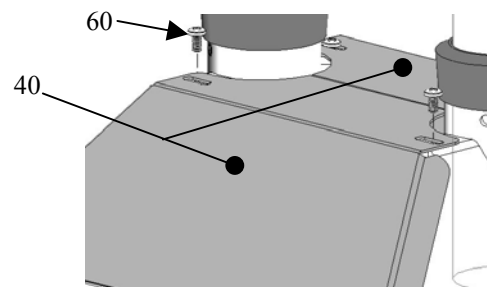

Figure 5. Install Covers