

---

# INSTALLATION INSTRUCTIONS

---

## POLE PITCH-ADJUSTABLE MOUNT FINISHING COVER

### TPA-105

The TPA-105 is an esthetically pleasing, functional cover for the pole pitch-adjustable mount.

**WARNING: IMPROPER INSTALLATION MAY RESULT IN SERIOUS PERSONAL INJURY!**  
When mounting Chief Manufacturing accessories, the structural system and mounting method **MUST** be capable of supporting 5 times the combined weight of the total installation.

Unpack and check contents:

- |  |  |
|--|--|
| (1) COVER, pole pitch-adjustable mount | (10) SCREW, pan head cap 10-24 X 3/8"        |
| (2) COVER, top/bottom                  | (10) BOLT, button head security 10-24 X 3/8" |
| (1) WRENCH, Allen, security, 5/32"     |  |

1. Using six 10-24 X 3/8" pan head cap screws or optional security screws (included), secure top and bottom cover to pole mount cover (see Figure 1).

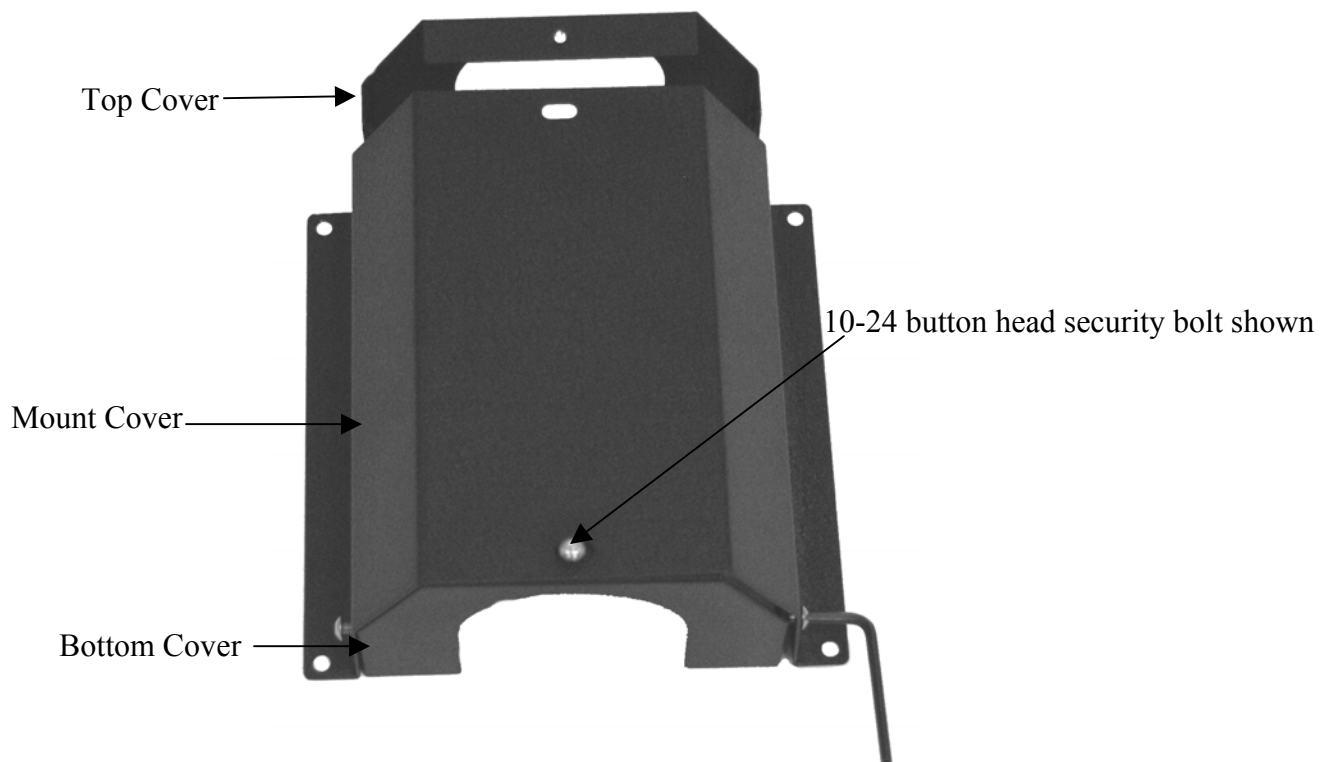

**Figure 1. Attach Top and Bottom Covers**

2. Place the pole pitch-adjustable mount cover over the pitch-adjustable pole mount (see Figure 2) on pole.
3. Using four 10-24 3/8" hex head bolts or optional security bolts (included), secure pole mount cover to mount.



**CHIEF MANUFACTURING INC.**  
1-800-582-6480 952-894-6280 FAX 952-894-6918  
12800 HIGHWAY 13 SOUTH, SUITE 500  
SAVAGE, MINNESOTA 55378 USA

**8807-000003**  
2003 Chief Manufacturing  
[www.chiefmfg.com](http://www.chiefmfg.com)  
06/03

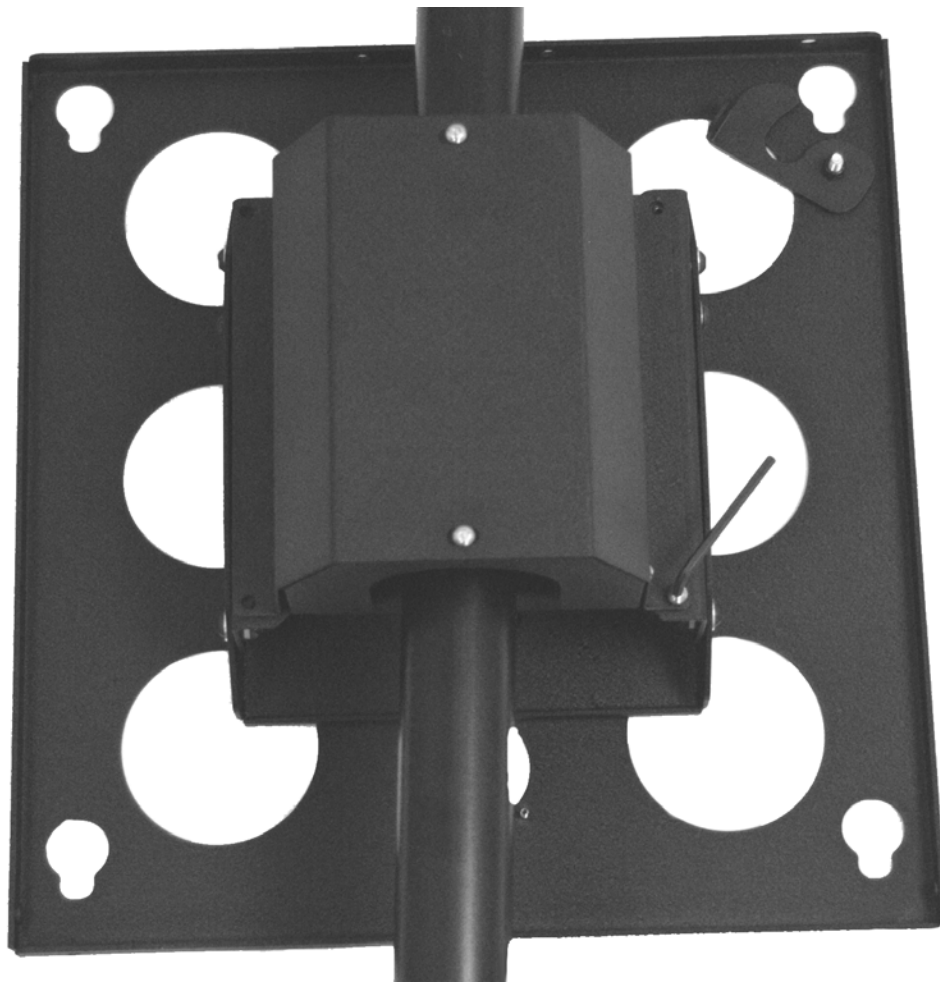

**Figure 2. TPA-105 on Pitch-Adjustable Mount**