

INSTALLATION INSTRUCTIONS

CEILING PLATE

CMA-390/CMA-391

Prior to assembly, unpack carton completely and verify contents.

If you are missing any of the following components, please contact Customer Service at 1-800/582-6480

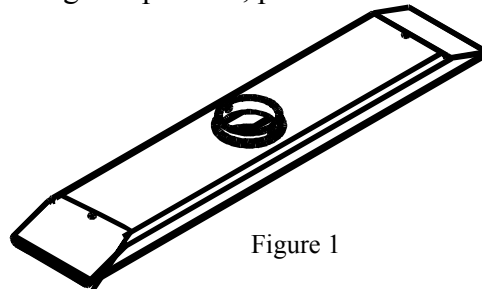

Figure 1

- (1) 3.5X18 or 3.5X26 Mounting Adapter Plate
- (4) Flat Washer
- (2) Mount End Covers

- (2) 6-32X5/16" Phillips Head Screws
- (4) 1/4 X 3.5" Hex Head Lag Screw

BEFORE PROCEEDING, READ INSTALLATION INSTRUCTIONS COMPLETELY

WARNING: IMPROPER INSTALLATION MAY RESULT IN SERIOUS PERSONAL INJURY!

When mounting Chief Manufacturing accessories, the structural system and mounting method **MUST** be capable of supporting 5 times the combined weight of the total installation.

NOTE: The threaded center mounting hole accepts an optional standard threaded pipe (not included).

1. Using the mounting adapter plate as a template, locate and, mark two 16" or 24" on center ceiling joists.
2. Drill four 1/8" diameter pilot holes 3 1/2" deep.
3. Secure the mounting plate to the ceiling joist using four washers and lag screws provided (see Figure 2). Tighten securely.
4. Slip on both end covers and secure using two 6-32X5/16" Phillips head screws (see Figure 3).

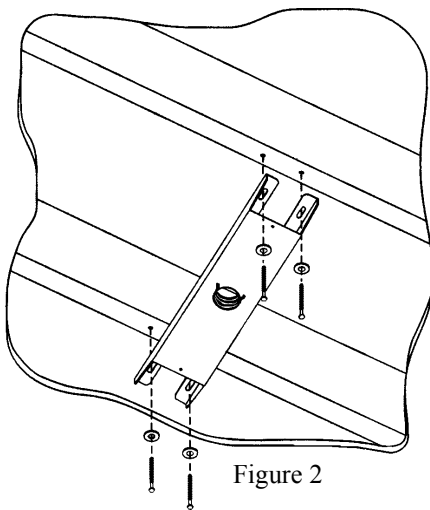

Figure 2

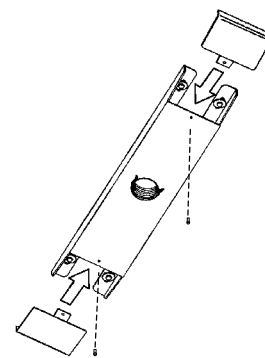

Figure 3



CHIEF MANUFACTURING INC.
1-800-582-6480 952-894-6280 FAX 952-894-6918
12800 HIGHWAY 13 SOUTH, SUITE 500
SAVAGE, MINNESOTA 55378 USA

8803-000030
2002 Chief Manufacturing
www.chiefmfg.com

01/04