

INSTALLATION INSTRUCTIONS

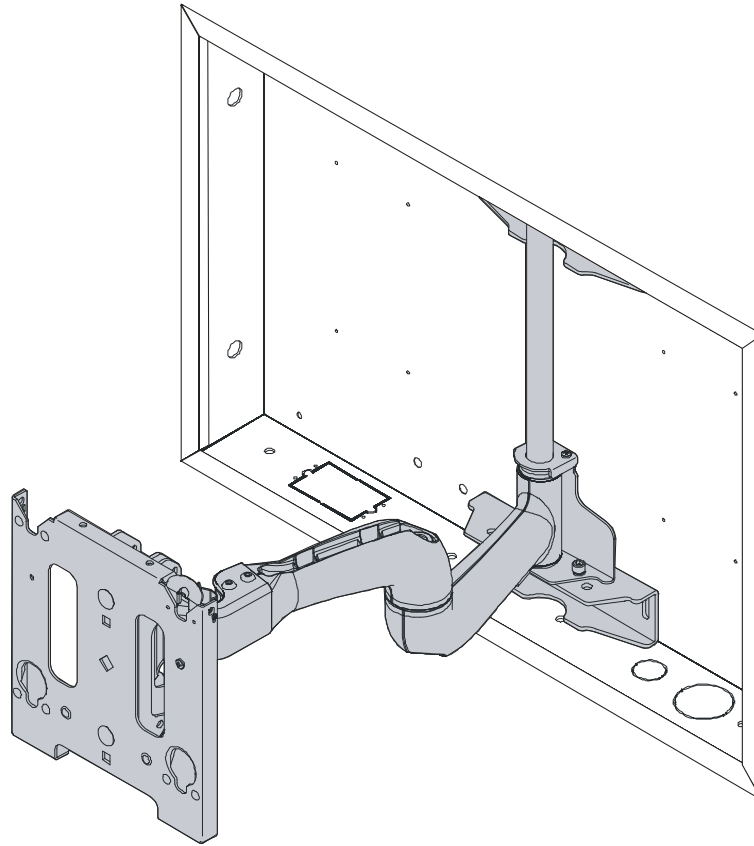

Medium Flat Panel In-Wall Swing Arm Mount

DISCLAIMER

CSAV, Inc., and its affiliated corporations and subsidiaries (collectively, "CSAV"), intend to make this manual accurate and complete. However, CSAV makes no claim that the information contained herein covers all details, conditions or variations, nor does it provide for every possible contingency in connection with the installation or use of this product. The information contained in this document is subject to change without notice or obligation of any kind. CSAV makes no representation of warranty, expressed or implied, regarding the information contained herein. CSAV assumes no responsibility for accuracy, completeness or sufficiency of the information contained in this document.

! IMPORTANT WARNINGS AND CAUTIONS!

! WARNING: A WARNING alerts you to the possibility of serious injury or death if you do not follow the instructions.

! CAUTION: A CAUTION alerts you to the possibility of damage or destruction of equipment if you do not follow the corresponding instructions.

! WARNING: Failure to read, thoroughly understand, and follow all instructions can result in serious personal injury, damage to equipment, or voiding of factory warranty! It is the installer's responsibility to make sure all components are properly assembled and installed using the instructions provided.

! WARNING: Failure to provide adequate structural strength for the installation of this kit can result in serious personal injury or damage to equipment! It is the installer's responsibility to make sure the structure to which this kit is attached can support five times the combined weight of all equipment.

! WARNING: Exceeding the weight capacity can result in serious personal injury or damage to equipment! It is the installer's responsibility to make sure the combined weight of all components attached to this accessory does not exceed 125 lbs (57 kg).

LEGEND

	Tighten Fastener
	Apretar elemento de fijación
	Befestigungsteil festziehen
	Apertar fixador
	Serrare il fissaggio
	Bevestiging vastdraaien
	Serrez les fixations

	Loosen Fastener
	Aflojar elemento de fijación
	Befestigungsteil lösen
	Desapertar fixador
	Allentare il fissaggio
	Bevestiging losdraaien
	Desserrez les fixations

	Hex-Head Wrench
	Llave de cabeza hexagonal
	Sechskantschlüssel
	Chave de cabeça sextavada
	Chiave esagonale
	Zeskantsleutel
	Clé à tête hexagonale

	Phillips Screwdriver
	Destornillador Phillips
	Kreuzschlitzschraubendreher
	Chave de fendas Phillips
	Cacciavite a stella
	Kruiskopschroevendraaier
	Tournevis à pointe cruciforme

TOOLS REQUIRED FOR INSTALLATION AND PARTS

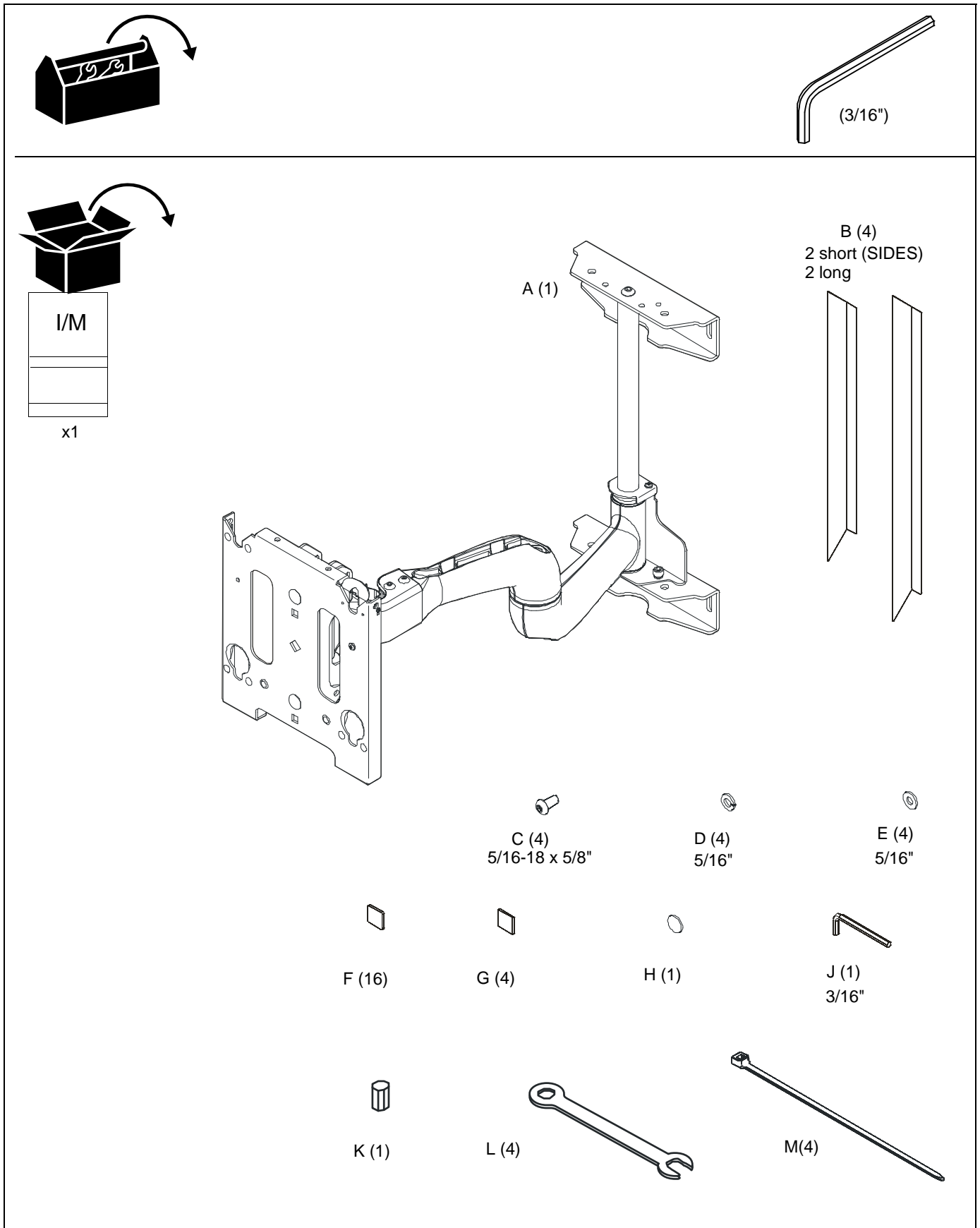

Figure 1

Installation

The following procedure assumes that a Chief Model PAC501 In-Wall accessory has previously been installed following the installation instructions provided with the PAC501. If a PAC501 is not installed or there are any other questions regarding the installation of this accessory, immediately contact a Chief Customer Service representative by calling 800-582-6480 or by visiting www.chiefmfg.com.

⚠ WARNING: IMPROPER INSTALLATION CAN LEAD TO MOUNT FALLING CAUSING SEVERE PERSONAL INJURY OR DAMAGE TO EQUIPMENT! DO NOT deviate from installation instructions provided. **DO NOT** substitute hardware.

The PAC501 is designed to accommodate up to 5" of right or left display offset. This is accomplished by aligning the upper and lower mounting brackets on the MWRIW with either the right hand or left hand mounting holes in the PAC501. (See Figure 2)

1. Align mounting holes in swing arm UPPER and LOWER mounting brackets with four mounting holes in PAC501. (See Figure 2)

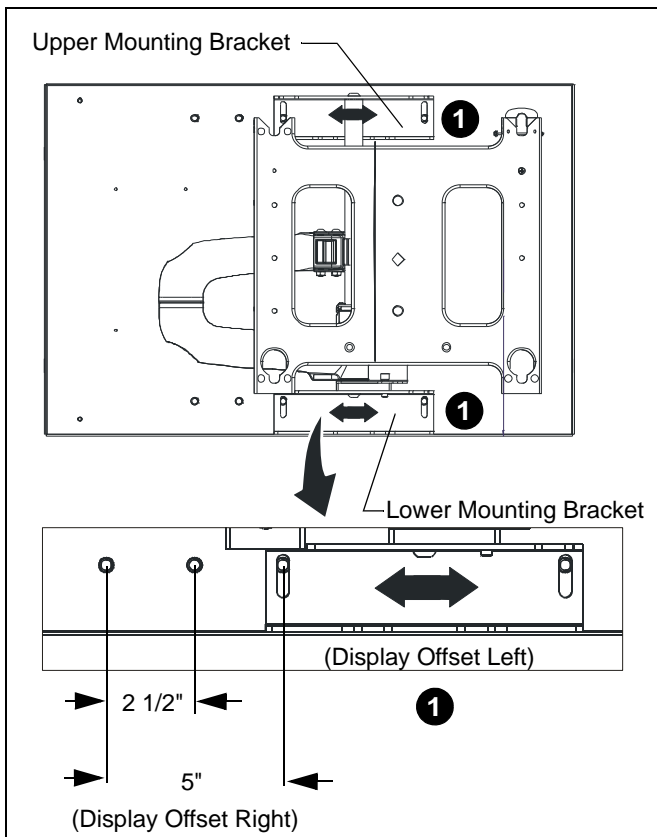

Figure 2

2. Secure swing arm to PAC501 using four button head cap screws (C), four lock washers (D) and four flat washers (E). (See Figure 3)

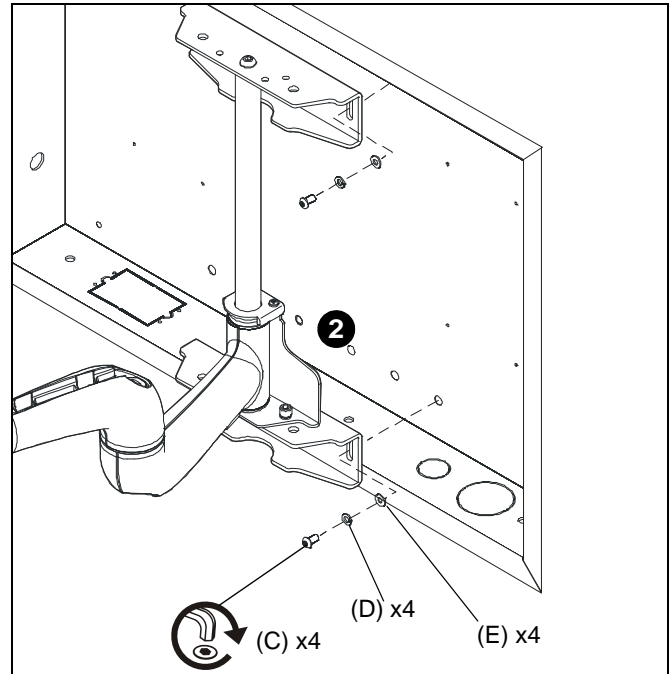

Figure 3

Trim Installation

To install optional trim;

1. Remove paper covering adhesive and affix three tape squares (F) to inside lower flange of each trim piece (B). (See Figure 4)
2. Orient trim pieces (B) as shown in figure below. (See Figure 4)
3. Remove paper covering adhesive back from tape squares (F) on trim and press trim (B) against inner wall of box. (See Figure 4)

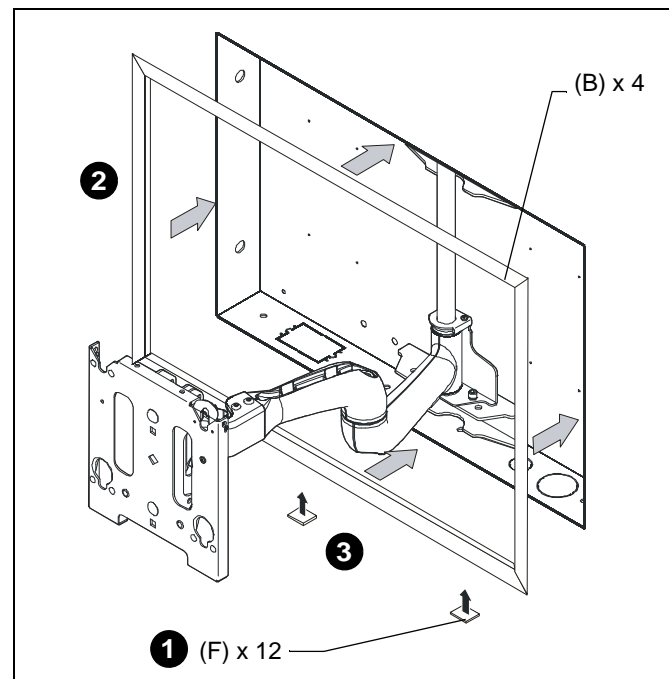

Figure 4

Display Installation

⚠ WARNING: IMPROPER INSTALLATION CAN LEAD TO MOUNT FALLING CAUSING SEVERE PERSONAL INJURY OR DAMAGE TO EQUIPMENT! DO NOT install display in a manner other than that specified by the manufacturer. Certain displays may require the use of an interface bracket for proper installation of the display. If an interface bracket is not installed or there are any other questions regarding the installation of the display, immediately contact a Chief Customer Service representative by calling 800-582-6480 or by visiting www.chiefmfg.com.

⚠ WARNING: IMPROPER INSTALLATION CAN LEAD TO MOUNT FALLING CAUSING SEVERE PERSONAL INJURY OR DAMAGE TO EQUIPMENT. Displays can weigh in excess of 40 lbs (18.1kg). ALWAYS use two people and proper lifting techniques when installing display.

⚠ WARNING: IMPROPER INSTALLATION CAN LEAD TO MOUNT FALLING CAUSING SEVERE PERSONAL INJURY OR DAMAGE TO EQUIPMENT. Make sure mounting buttons on display are properly seated in mounting holes in faceplate.

To install display:

1. Move mount faceplate to extended position by grasping faceplate and pulling outward away from wall. (See Figure 5)
2. While supporting both sides of display, align four mounting buttons on display or interface bracket with four mounting holes in faceplate. (See Figure 5)
3. Lower display into place listening for audible "click" to ensure recessed area of mounting buttons are properly seated in lower area of mounting holes and "click lock" mechanism has engaged. (See Figure 5) and (See Figure 6)

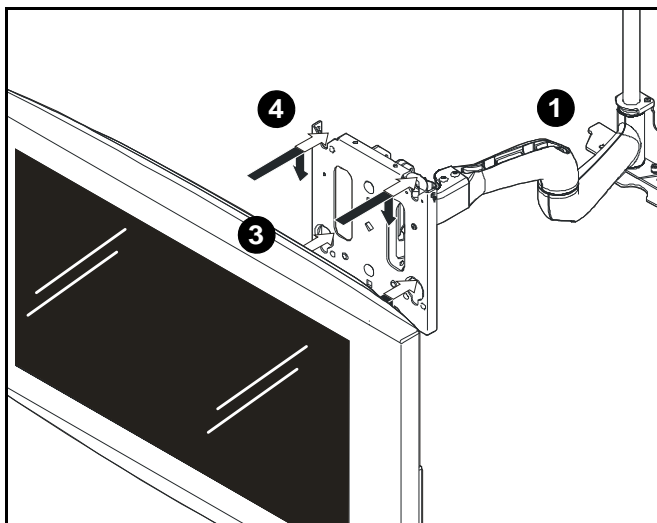

Figure 5

NOTE: Holes are provided in the faceplate for use with a padlock or similar locking device, if desired. In addition, the pin and nut may be removed from the upper holes and moved to the lower holes for use as a more

permanent locking device. (See Figure 6)

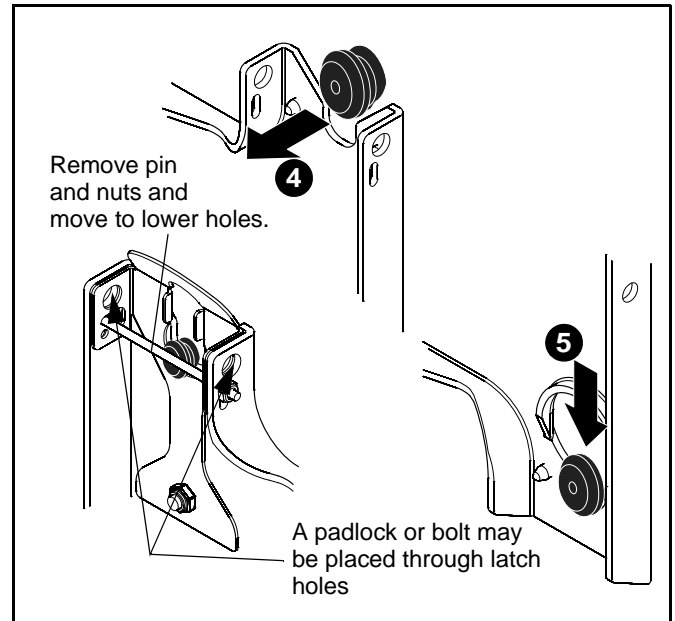

Figure 6

CABLE MANAGEMENT

⚠ WARNING: IMPROPER INSTALLATION CAN LEAD TO SERIOUS PERSONAL INJURY OR DAMAGE TO EQUIPMENT! Make sure cables do not run through pinch points.

1. Loosen front and rear cable clamps on top arm. (See Figure 7)
2. Thread cable ties (E) under cable clamps and secure clamps to top arm. (See Figure 7)
3. Route power/audio/video cables through the cable channel in top arm (See Figure 7), allowing sufficient slack in cables for left/Right movement of display and swing arm and also swing arm extension and retraction.
4. Secure cables to top arm using two cable ties (E).
5. Repeat steps 1 through 4 for lower arm.

⚠ WARNING: IMPROPER INSTALLATION CAN LEAD TO SERIOUS PERSONAL INJURY OR DAMAGE TO EQUIPMENT! DO NOT route cables through holes in faceplate.

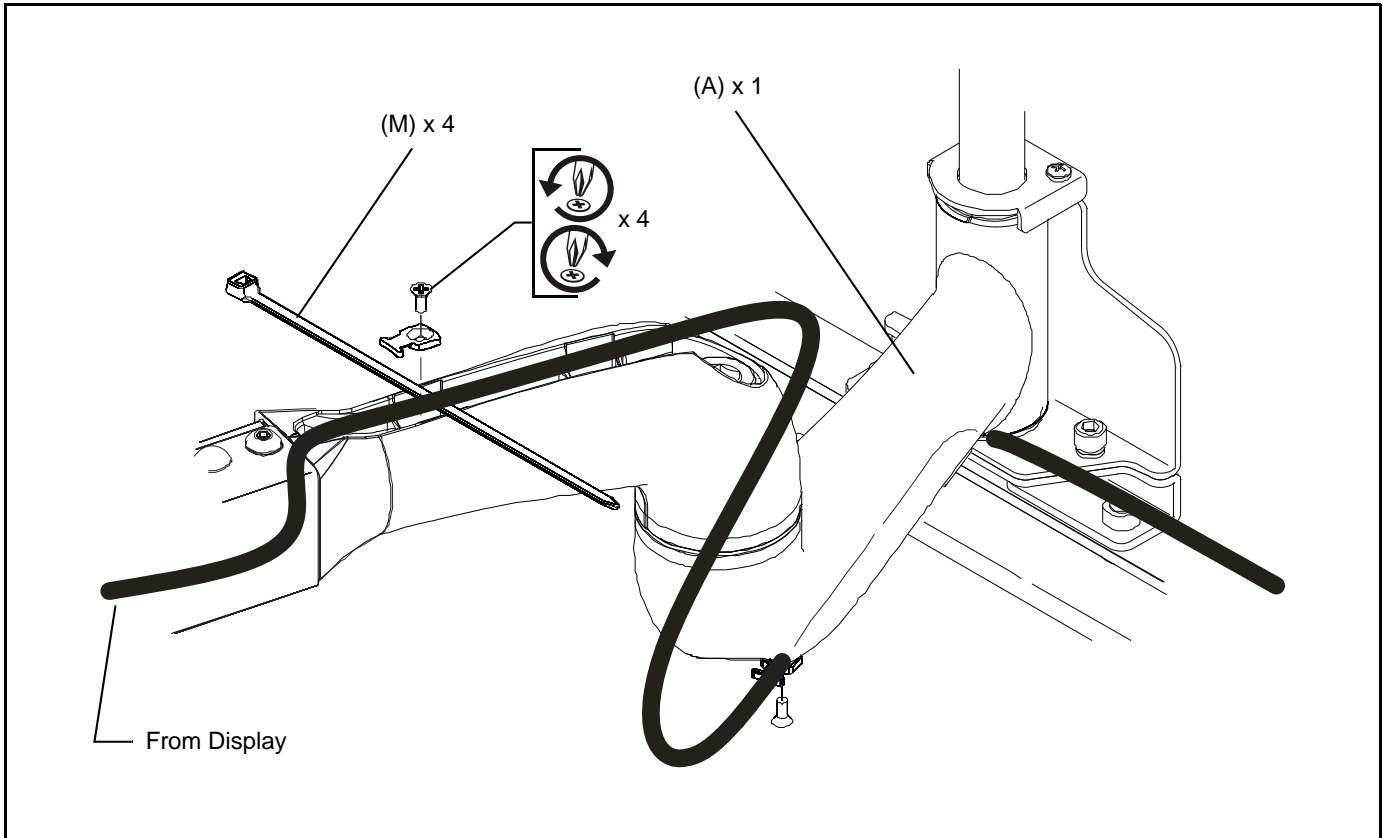

Figure 7

ADJUSTMENTS

Pitch Tension Adjustment

To adjust display pitch tension:

1. With display installed, tighten or loosen two screws, one on each side, using the 5/32" hex wrench. (See Figure 8)
2. Check for desired tension.
3. Repeat Steps 1 and 2 until desired tension is obtained.

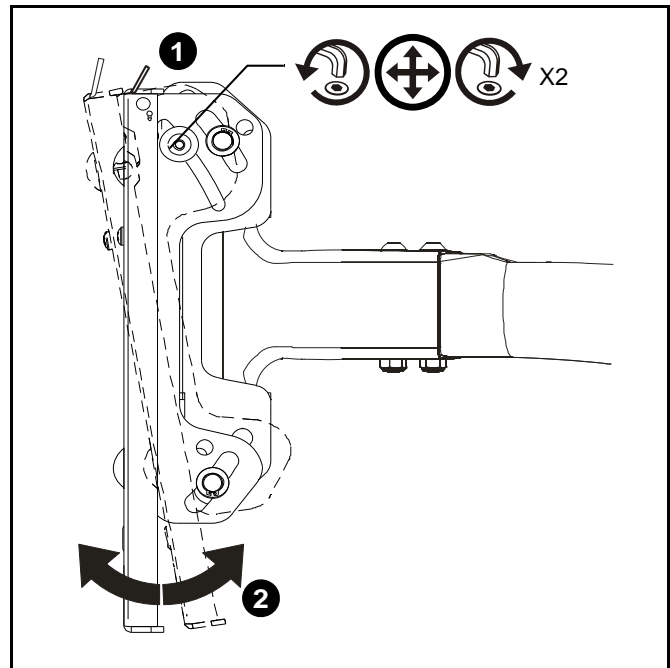

Figure 8

Roll Adjustment

The MWR allows for the horizontal alignment (Roll) of the display to be adjusted up to 2 deg. right or left to level the display after installing.

To adjust Roll:

1. Loosen the roll tension adjustment nut located on the back side of the faceplate assembly. (See Figure 9)
2. Level display.

NOTE: If display will not level slightly loosen top nut as well.

3. Tighten roll tension adjustment nut. (See Figure 9)

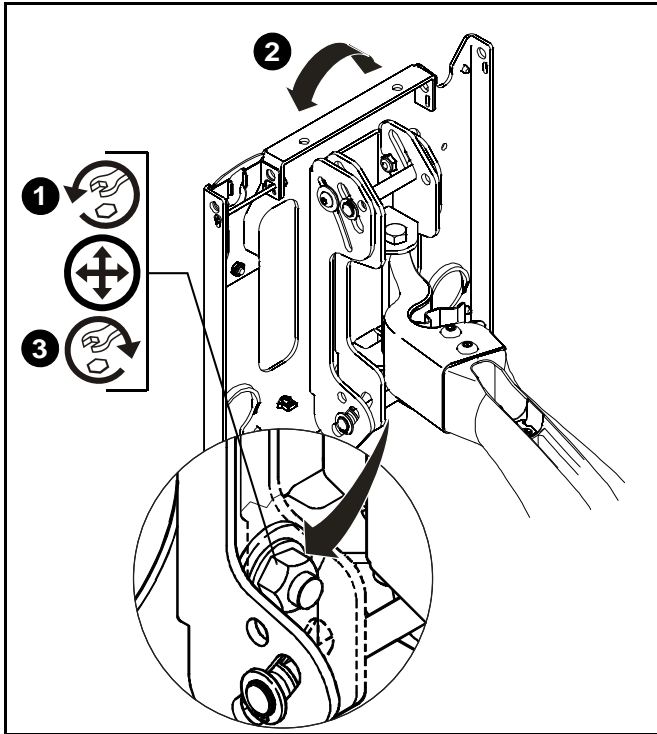

Figure 9

Swing Arm Tension Adjustment

Swing arm tension is pre-set at the factory and is adjusted to accommodate displays with weights near the top of the mounts capacity.

If smaller displays are used it may be difficult to reposition the display after mounting. Swing arm tension can be adjusted to compensate for smaller display by:

The display must be mounted prior to adjusting swing arm tension.

1. Locate the adjustment bar (K) and adjustment wrench (L).
2. Place adjustment bar (K) into socket head cap screw located at swing arm pivot point. (See Figure 10)

NOTE: The display may need to be repositioned in order to gain access to the tension adjustment screw(s).

3. Check swing arm tension. If desired tension is present, tension adjustment is complete. If additional tension adjustment is required, repeat steps 2 thru 4 until desired tension is achieved.

NOTE: If changing from a smaller display to a larger display may be necessary to increase swing arm

tension.

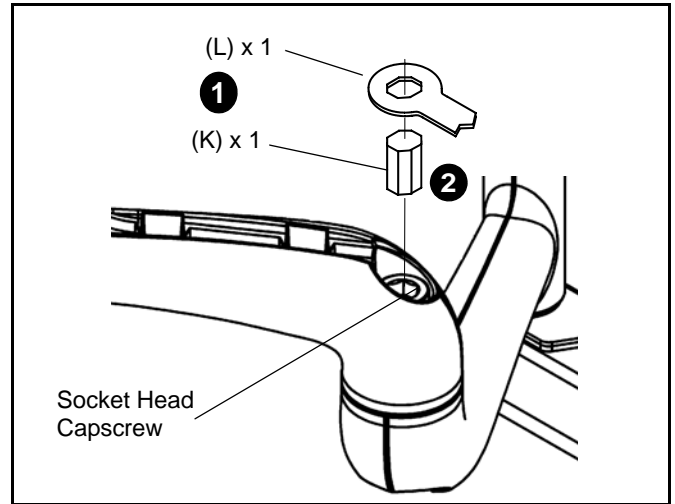

Figure 10

4. Using the adjustment wrench (L), turn adjustment bar (K) clockwise to increase swing arm tension or counterclockwise to reduce swing arm tension. (Small adjustments of 1/8 turn or less are typically all that is required to achieve desired tension.) (See Figure 11) and (See Figure 12)

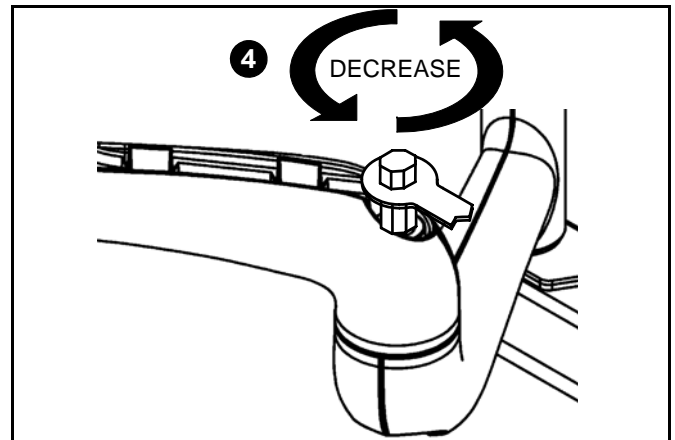

Figure 11

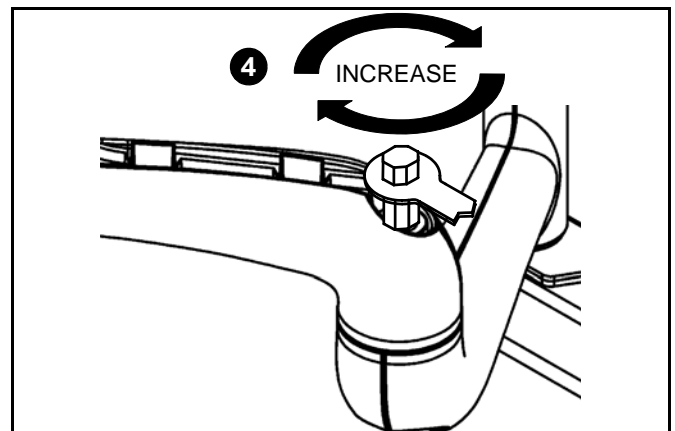

Figure 12



8805-000244
©2007 Chief Manufacturing
www.chiefmfg.com
10/07

USA/International	A 8401 Eagle Creek Parkway, Savage, MN 55378 P 800.582.6480 / 952.894.6280 F 877.894.6918 / 952.894.6918
Europe	A Fellenoord 130 5611 ZB EINDHOVEN, The Netherlands P +31 40 2668620 F +31 (0) 40 2668615
Asia Pacific	A Room 301, Block D, Lily YinDu International Building LuoGang, BuJi Town, Shenzhen, CHINA. Post Code: 518112 深圳市布吉罗岗百合银都国际大厦D栋301 P +86-755-8996 9226 ; 8996 9236 ; 8996 9220 F +86-755-8996 9217