

---

# INSTALLATION INSTRUCTIONS

---

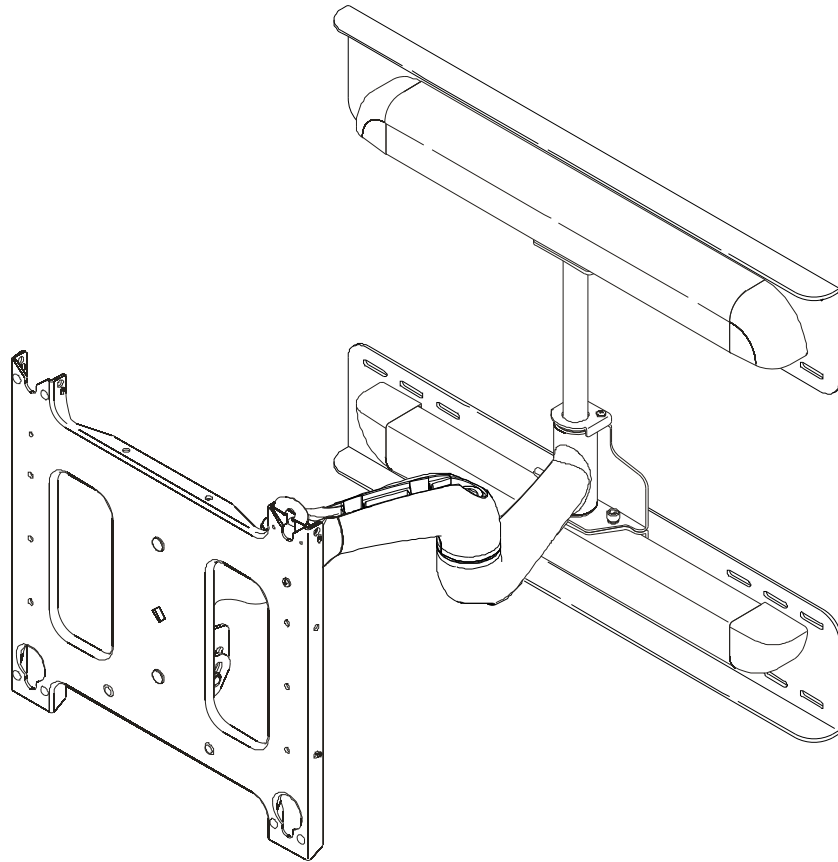

---

## Large Flat Panel Steel Stud Wall Mount

---

## DISCLAIMER

CSAV, Inc., and its affiliated corporations and subsidiaries (collectively, "CSAV"), intend to make this manual accurate and complete. However, CSAV makes no claim that the information contained herein covers all details, conditions or variations, nor does it provide for every possible contingency in connection with the installation or use of this product. The information contained in this document is subject to change without notice or obligation of any kind. CSAV makes no representation of warranty, expressed or implied, regarding the information contained herein. CSAV assumes no responsibility for accuracy, completeness or sufficiency of the information contained in this document.

## IMPORTANT WARNINGS AND CAUTIONS!

 **WARNING:** A WARNING alerts you to the possibility of serious injury or death if you do not follow the instructions.

 **CAUTION:** A CAUTION alerts you to the possibility of damage or destruction of equipment if you do not follow the corresponding instructions.

 **WARNING:** Failure to read, thoroughly understand, and follow all instructions can result in serious personal injury, damage to equipment, or voiding of factory warranty! It is the installer's responsibility to make sure all components are properly assembled and installed using the instructions provided.

 **WARNING:** Failure to provide adequate structural strength for the installation of this kit can result in serious personal injury or damage to equipment! It is the installer's responsibility to make sure the structure to which this mount is attached can support five times the combined weight of all equipment.

 **WARNING:** Exceeding the weight capacity can result in serious personal injury or damage to equipment! It is the installer's responsibility to make sure the combined weight of all components attached to this accessory does not exceed 100lbs (45.3 kg) if being installed on a wall with a minimum 1/2" thick drywall, or 125 lbs (56.7 kg) if being installed on a wall with a minimum 5/8" thick drywall.

## LEGEND

	Tighten Fastener
	Apretar elemento de fijación
	Befestigungsteil festziehen
	Apertar fixador
	Serrare il fissaggio
	Bevestiging vastdraaien
	Serrez les fixations
	Сожмите Застежку

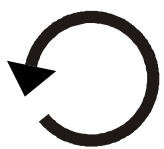
	Loosen Fastener
	Aflojar elemento de fijación
	Befestigungsteil lösen
	Desapertar fixador
	Allentare il fissaggio
	Bevestiging losdraaien
	Desserrez les fixations
	Ослабьте Застежку

	Open-Ended Wrench
	Llave de boca
	Gabelschlüssel
	Chave de bocas
	Chiave a punta aperte
	Steeksleutel
	Clé à fourche
Открытый Рывок	

	Adjust
	Ajustar
	Einstellen
	Ajustar
	Regolare
	Afstellen
	Ajuster
	Приспособьтесь

	Phillips Screwdriver
	Destornillador Phillips
	Kreuzschlitzschraubendreher
	Chave de fendas Phillips
	Cacciavite a stella
	Kruiskopschroevendraaier
	Tournevis à pointe cruciforme
	Отвертка

	Hex-Head Wrench
	Llave de cabeza hexagonal
	Sechskantschlüssel
	Chave de cabeça sextavada
	Chiave esagonale
	Zeskantsleutel
	Clé à tête hexagonale
	Главный ведьмой Рывок

### TOOLS REQUIRED FOR INSTALLATION AND PARTS

The diagram lists the following tools and parts:

- Tools:**
  - 1/2" (Ø13mm) Glue Gun
  - 1/4" (Ø13mm) Screws
  - Pencil
  - Phillips Screwdriver
  - Wrench
- Parts:**
  - A (1)**: Main mounting bracket
  - B (8) (1/4")**: Washers
  - C (8) (1/4"-20 x 1 3/4")**: Screws
  - D (8) (1/4"-20 SNAPTGGLE BB)**: Snap toggles
  - E (2)**: Vertical trim pieces
  - F (1)**: Backplate
  - G (4)**: Corner caps
  - H (1)**: Spacers
  - J (2)**: End caps
- Other:**
  - I/M**: Installation Manual (x1)

### Site Requirements

**⚠ WARNING:** IMPROPER INSTALLATION CAN LEAD TO EQUIPMENT FALLING CAUSING SERIOUS PERSONAL INJURY OR DAMAGE TO EQUIPMENT! The figure below identifies the minimum requirements for installation of display mounts onto a steel stud structure. If the structure or its components do not meet these requirements contact the mount manufacturer for specific instructions before attempting installation. It should also be noted that no other equipment should be mounted to the same stud.

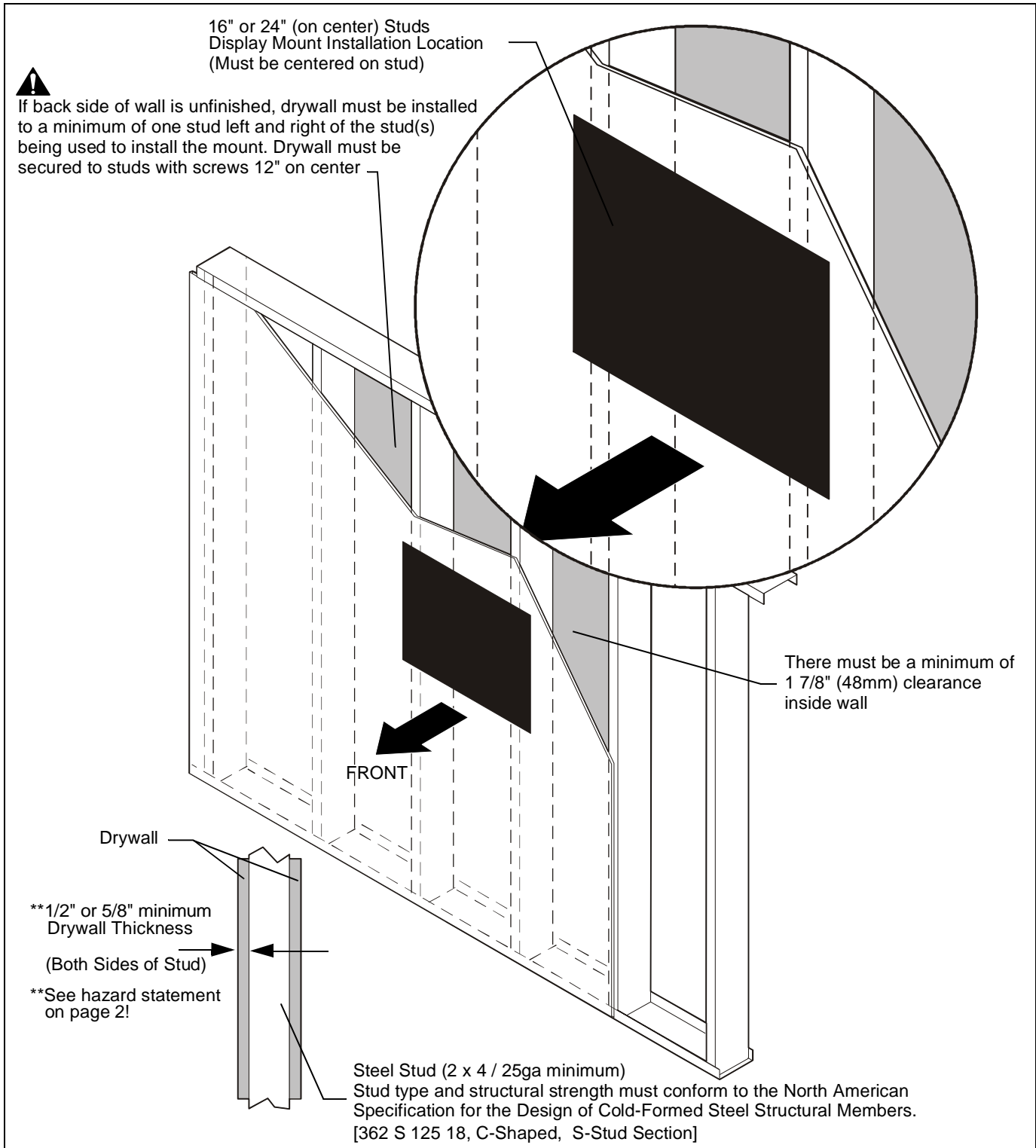

Figure 1

## Mount Installation And Adjustment

### Mount Installation

After determining the site meets the installation requirements:

1. Identify desired mounting location on wall.
2. Using a stud finder or similar method locate studs.
3. Align mounting holes in mount with studs making sure mounting holes are centered on studs. (See Figure 2)



**WARNING:** IMPROPER INSTALLATION CAN LEAD TO EQUIPMENT FALLING CAUSING SERIOUS PERSONAL INJURY OR DAMAGE TO EQUIPMENT! Make sure upper and lower mounting holes are used on both sides of both the upper and lower wall plates. (See Figure 2)

4. Mark location of eight mounting holes on wall.
5. Drill eight 1/2" (Ø13mm) holes. (See Figure 2)

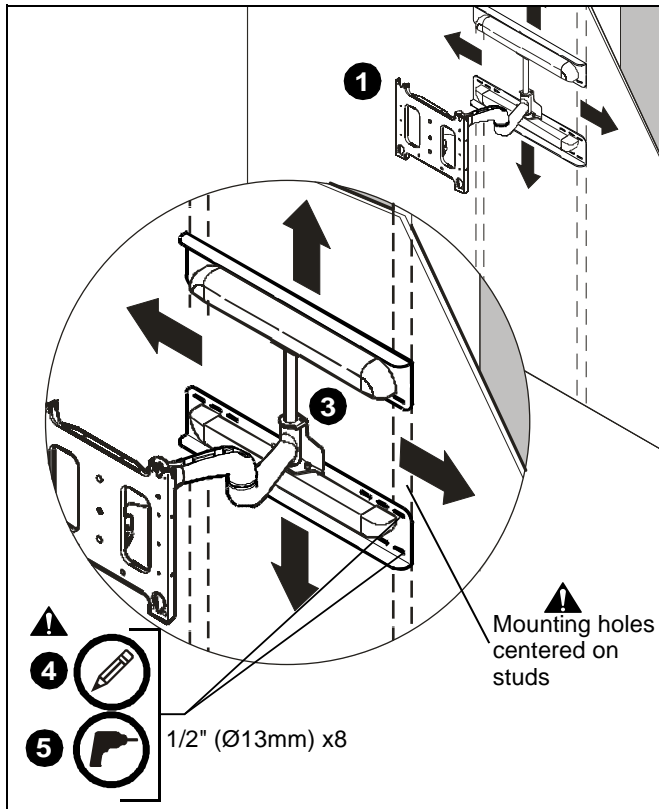

Figure 2

6. Hold metal channel on anchor (D) flat alongside plastic straps and slide channel through hole. (See Figure 3)

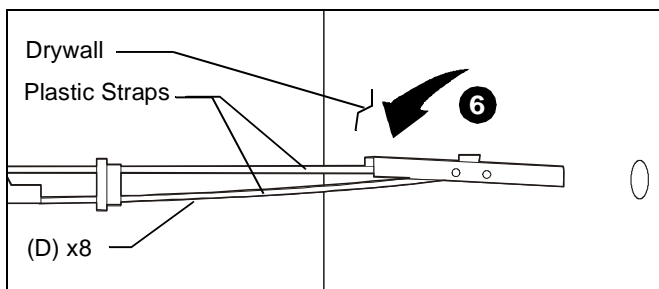

Figure 3

7. Holding plastic straps on anchor (D), pull anchor away from wall until channel rests flush behind wall making sure anchor channel is positioned vertically on stud as show in figures below. (See Figure 4)
8. Slide plastic cap on anchor (D) towards wall until flange of cap is flush with wall. (See Figure 4)

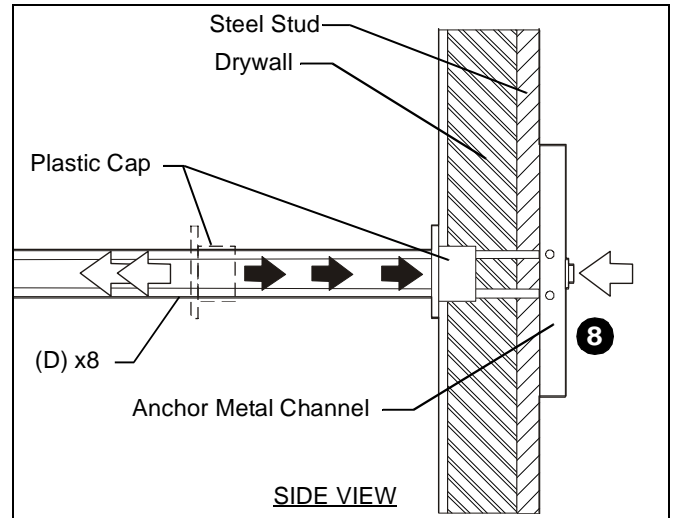

Figure 4

9. Snap off plastic straps on anchor at wall by pushing side to side, snapping off straps level with flange of plastic cap. (See Figure 5)
10. Repeat steps 6 through 9 for each mounting hole.

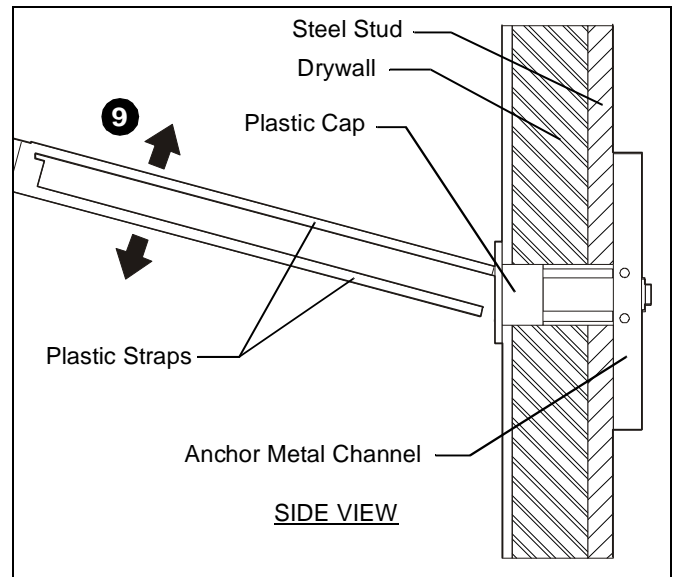

Figure 5

11. Place mount over anchors and align mounting holes in display mount with holes in anchors. (See Figure 6)
12. Place flat washer (B) onto Phillips pan head screws (C).
13. Insert Phillips pan head screws (C) with flat washer (B) through mounting hole in display mount and into anchor (D) and tighten until flush against mount. DO NOT overtighten! (See Figure 6)
14. Repeat steps 6 through 13 for remaining 7 mounting holes.

**⚠ WARNING:** IMPROPER INSTALLATION CAN LEAD TO EQUIPMENT FALLING CAUSING SERIOUS PERSONAL INJURY OR DAMAGE TO EQUIPMENT! Overtightening of mounting hardware can damage the steel studs. **DO NOT** overtighten mounting hardware!

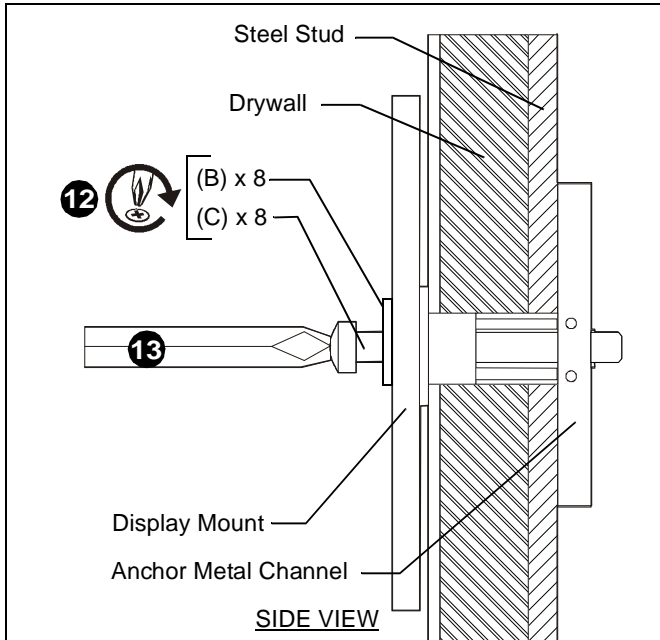

Figure 6

**Cover Installation**

To install channel covers:

1. Install upper wall channel cover (E) by tipping cover top down and positioning as shown in figure below. (See Figure 7)
2. Lower bottom of upper wall channel cover (E) and tap firmly across bottom of channel to lock in place as shown in figure below. (See Figure 7)
3. Install R.H. and L.H. end caps (G) by aligning tabs on end caps with slots in wall channel and sliding tabs into channel until end cap is flush with wall channel cover cover (E).
4. Repeat steps 4 through 6 above for lower wall channel cover and end caps.

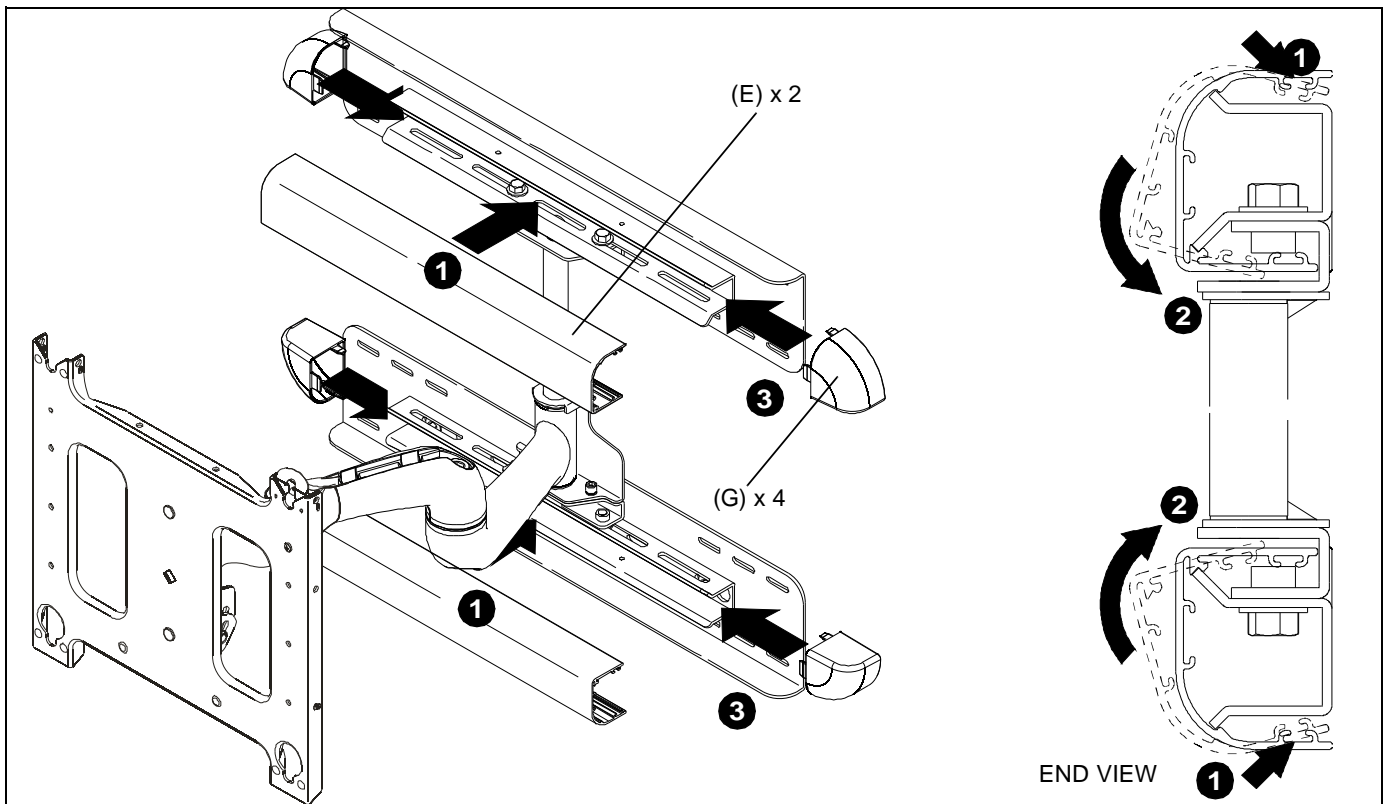

Figure 7

## Display Installation



**WARNING:** IMPROPER INSTALLATION CAN LEAD TO MOUNT FALLING CAUSING SEVERE PERSONAL INJURY OR DAMAGE TO EQUIPMENT. Displays can weigh in excess of 40 lbs (18.1kg). ALWAYS use two people and proper lifting techniques when installing display.



**WARNING:** IMPROPER INSTALLATION CAN LEAD TO MOUNT FALLING CAUSING SEVERE PERSONAL INJURY OR DAMAGE TO EQUIPMENT. Make sure mounting buttons on display are properly seated in mounting holes in faceplate.

To install display:

1. Move mount faceplate to extended position by grasping faceplate and pulling outward away from wall. (See Figure 8)
2. While supporting both sides of display, align four mounting buttons on display or interface bracket with four mounting holes in faceplate. (See Figure 8)
3. Lower display into place listening for audible "click" to ensure recessed area of mounting buttons are properly seated in lower area of mounting holes and "click lock" mechanism has engaged. (See Figure 8) and (See Figure 9)

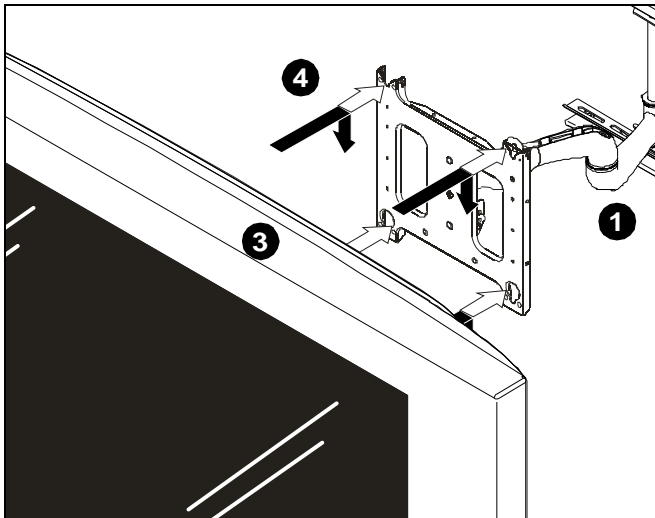

**Figure 8**

**NOTE:** Holes are provided in the faceplate for use with a padlock or similar locking device, if desired. In addition, the pin and nut may be removed from the upper holes and moved to the lower holes for use as a more permanent locking device. (See Figure 9)

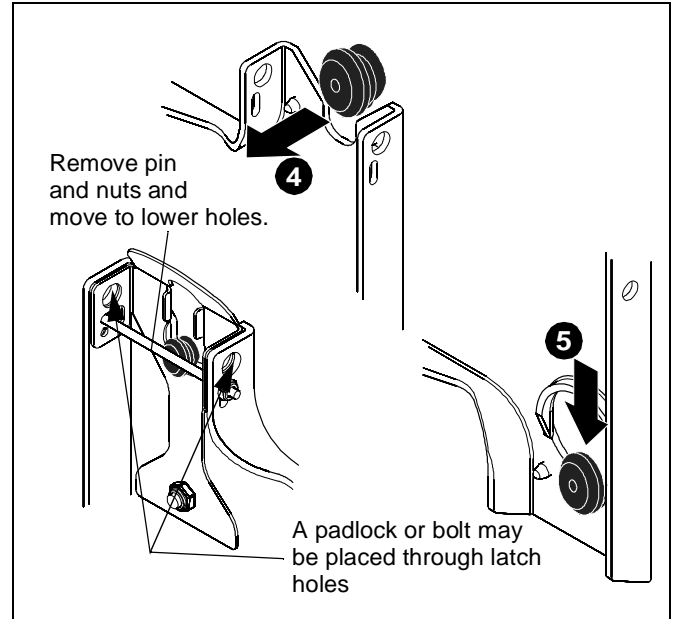

**Figure 9**

## CABLE MANAGEMENT



**WARNING:** IMPROPER INSTALLATION CAN LEAD TO SERIOUS PERSONAL INJURY OR DAMAGE TO EQUIPMENT! Make sure cables do not run through pinch points.

1. Loosen front and rear cable clamps on top arm. (See Figure 8)
2. Thread cable ties (E) under cable clamps and secure clamps to top arm. (See Figure 8)
3. Route power/audio/video cables through the cable channel in top arm (See Figure 8), allowing sufficient slack in cables for left/Right movement of display and swing arm and also swing arm extension and retraction.
4. Secure cables to top arm using two cable ties (E).
5. Repeat steps 1 through 4 for lower arm.



**WARNING:** IMPROPER INSTALLATION CAN LEAD TO SERIOUS PERSONAL INJURY OR DAMAGE TO EQUIPMENT! DO NOT route cables through holes in faceplate.

## ADJUSTMENTS

### Roll Adjustment

The mount allows for the horizontal alignment (Roll) of the display to be adjusted up to 2 deg. right or left to level the display after installing.

To adjust Roll:

1. Loosen the roll tension adjustment nut located on the back side of the faceplate assembly. (See Figure 10)
2. Level display.
3. Tighten roll tension adjustment nut. (See Figure 10)

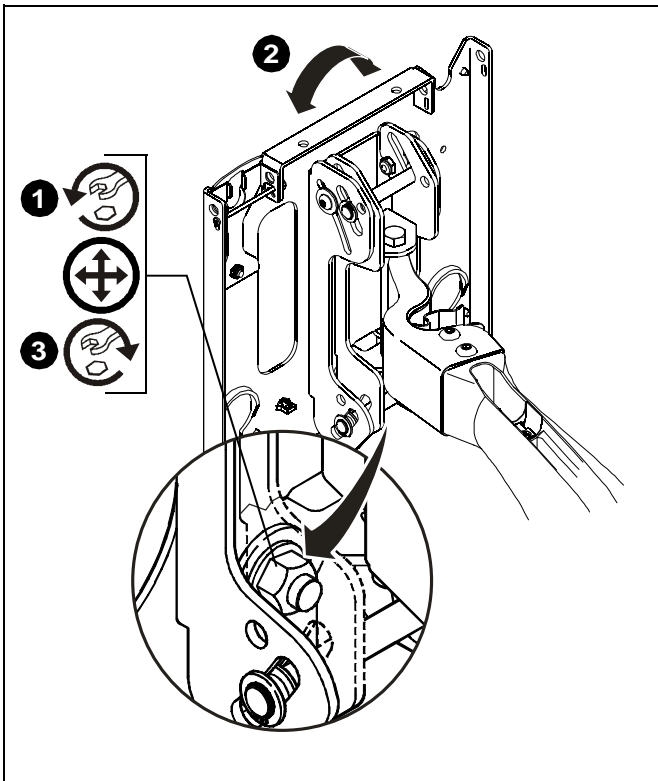

Figure 10

### Swing Arm Tension Adjustment

Swing arm tension is pre-set at the factory and is adjusted to accommodate displays with weights near the top of the mounts capacity.

If smaller displays are used it may be difficult to reposition the display after mounting. Swing arm tension can be adjusted to compensate for smaller display by:

The display must be mounted prior to adjusting swing arm tension.

1. Locate the adjustment bar (H) and adjustment wrench (J).
2. Place adjustment bar (H) into socket head cap screw located at swing arm pivot point. (See Figure 11)

**NOTE:** The display may need to be repositioned in order to gain access to the tension adjustment screw(s).

3. Check swing arm tension. If desired tension is present, tension adjustment is complete. If additional tension adjustment is required, repeat steps 2 thru 4 until desired tension is achieved.

**NOTE:** If changing from a smaller display to a larger display may be necessary to increase swing arm tension.

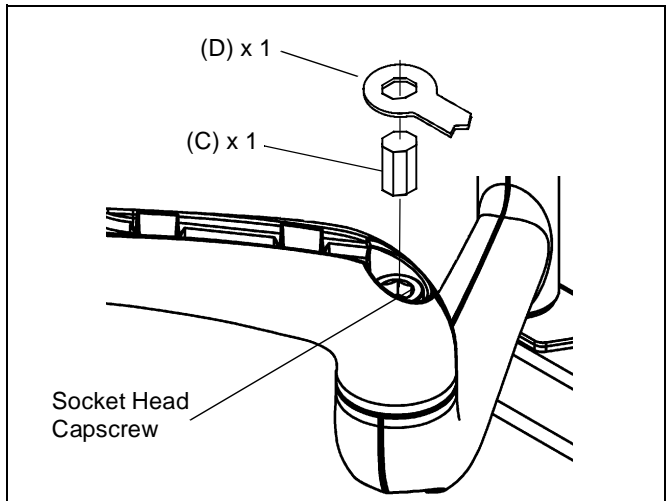

Figure 11

4. Using the adjustment wrench (D), turn adjustment bar (C) clockwise to increase swing arm tension or counterclockwise to reduce swing arm tension. (Small adjustments of 1/8 turn or less are typically all that is required to achieve desired tension.) (See Figure 12) and (See Figure 13)

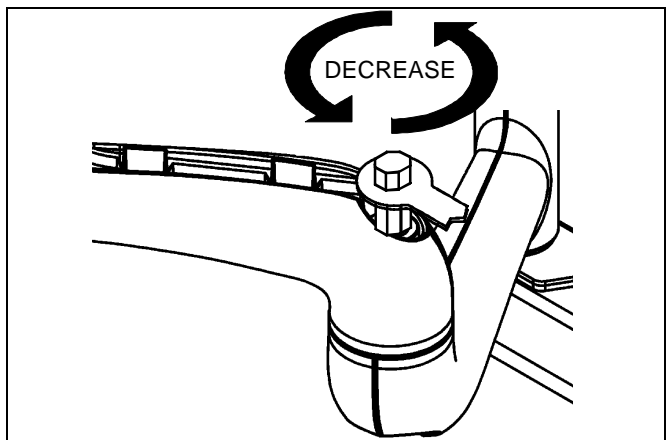

Figure 12

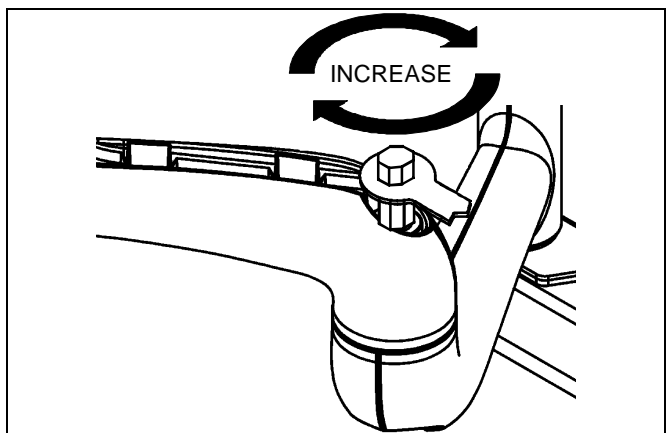

Figure 13





8832-000224 RevD  
©2007 Chief Manufacturing  
[www.chiefmfg.com](http://www.chiefmfg.com)  
08/07

<b>USA/International</b>	<b>A</b> 8401 Eagle Creek Parkway, Savage, MN 55378 <b>P</b> 800.582.6480 / 952.894.6280 <b>F</b> 877.894.6918 / 952.894.6918
<b>Europe</b>	<b>A</b> Fellenoord 130 5611 ZB EINDHOVEN, The Netherlands <b>P</b> +31 40 2668620 <b>F</b> +31 (0) 40 2668615
<b>Asia Pacific</b>	<b>A</b> Room 30I, Block D, Lily YinDu International Building LuoGang, BuJi Town, Shenzhen, CHINA. Post Code: 518112 深圳市布吉罗岗百合银都国际大厦D栋30I <b>P</b> +86-755-8996 9226 ; 8996 9236 ; 8996 9220 <b>F</b> +86-755-8996 9217