

---

# INSTALLATION INSTRUCTIONS

---

## Medium Flat Panel Single Swing Arm Wall Mount (JWS-210)

The JWS single swing arm wall mount is designed for mounting a medium sized flat panel display. The JWS can swing out from, or fold against, the wall depending on your ergonomic need. The mount can be tilted up and down to 15° of center.

The JWS is shipped with the VESA® 100mm/100mm Centris™ interface which is compatible with most medium flat panels.

To accommodate other mounting patterns in displays, the JWS comes with a VESA Plate that accommodates other VESA 200mm x 100mm and 200mm x 200mm mounting patterns. This VESA Plate can also be used with an MSB Custom Interface for non-VESA screens.

By design, the JWS can be configured to fit your medium flat panel display, providing that your display does not exceed the specified weight rating.



JWS-210

---

### BEFORE YOU BEGIN

---

- **⚠ CAUTION:** To prevent damage to your display and/or the JWS, which could affect or void factory warranty, thoroughly study all instructions and illustrations before you begin to install the mount. Pay particular attention to ALL Warnings and Cautions in this document.
- The maximum weight allowable for use with the JWS wall mount is 75 lbs (34 kg).
- The JWS wall mount is designed to be installed using wall studs or supporting framework. The structure to which the JWS wall mount is anchored must be capable of supporting **five times** the total weight of the mount and all attached equipment.
- If you have any questions about this installation, contact Chief Manufacturing at 1-800-582-6480.



## IMPORTANT WARNINGS and CAUTIONS!

<b>WARNING</b>	A <b>WARNING</b> alerts you to the possibility of serious injury or death if you do not follow the instructions.
<b>CAUTION</b>	A <b>CAUTION</b> alerts you to the possibility of damage or destruction of equipment if you do not follow the corresponding instructions.
<ul style="list-style-type: none"> <li><b>WARNING</b></li> </ul>	Improper installation can result in serious personal injury! Make sure that the structural members can support a redundant weight factor <i>five times</i> the total weight of the equipment. If not, reinforce the structure before installing the mount.
<ul style="list-style-type: none"> <li><b>WARNING</b></li> </ul>	Be aware of the potential for personal injury or damage to the equipment if it is not adequately mounted.
<ul style="list-style-type: none"> <li><b>WARNING</b></li> </ul>	The installer is responsible for verifying that the display to which the JWS mount is anchored will safely support the combined load of all attached components or other equipment.
<ul style="list-style-type: none"> <li><b>WARNING</b></li> </ul>	The weight of the display placed on the JWS must not exceed 75 lbs (34 kg), the maximum support weight of the JWS.
<ul style="list-style-type: none"> <li><b>WARNING</b></li> </ul>	Watch for pinch points. Do not put your fingers between movable parts.
<ul style="list-style-type: none"> <li><b>WARNING</b></li> </ul>	Make sure the mount and brackets are correctly oriented.
<ul style="list-style-type: none"> <li><b>CAUTION</b></li> </ul>	Check the unit for shipping damage before you begin the installation.

## DIMENSIONAL DRAWING

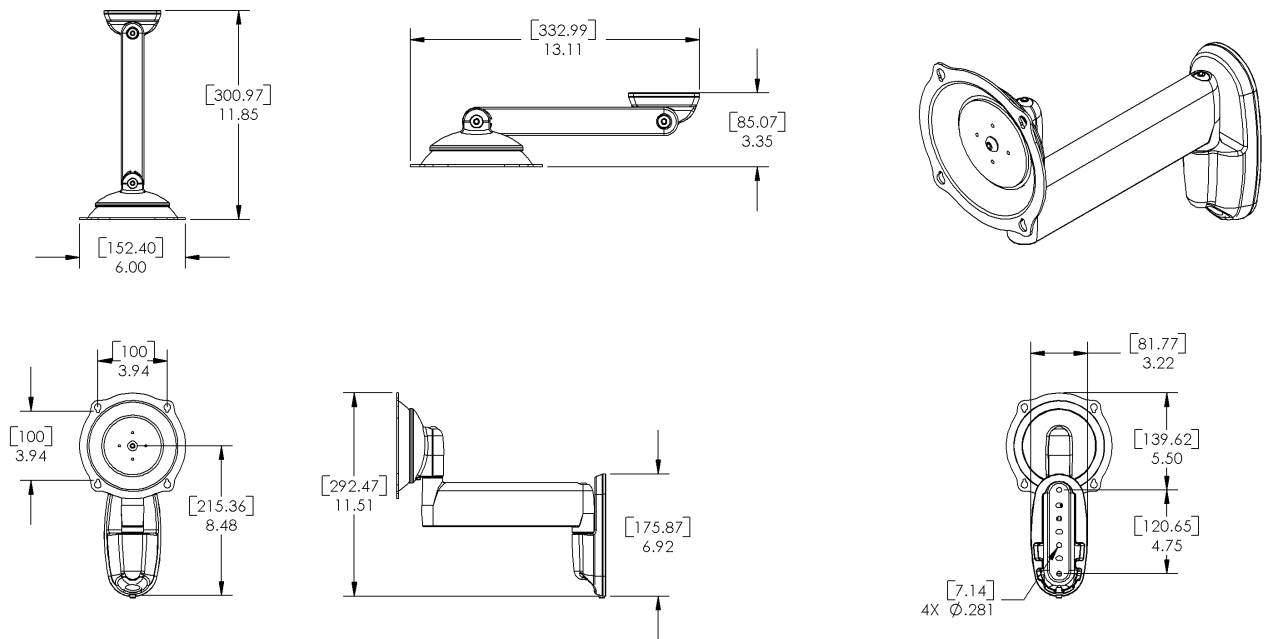

## CONTENTS

DIMENSIONAL DRAWING .....2  
 TOOLS REQUIRED FOR INSTALLATION .....3  
 INSPECT UNIT BEFORE INSTALLING .....3  
 SPECIFICATIONS .....3  
 INTRODUCTION .....4  
     Reference Chart.....4  
     Mounting-Hole Configurations .....4  
 COMPONENTS .....5  
 PARTS .....6  
 SECURE WALL BRACKET .....7  
 ATTACH MOUNT TO WALL BRACKET .....7  
 INSTALLATION (100mm x 100mm).....8  
     Flush Mount Centris Bracket to Display .....8  
     Recess Mount Centris Bracket to Display .....8  
 INSTALLATION (200mm x 100mm).....9  
     Attach VESA Plate to Display .....9  
     Attach Display to Centris Bracket.....9  
 INSTALLATION (200mm x 200mm).....10  
     Attach VESA Plate to Display .....10  
     Attach Display to Centris Bracket.....10  
 INSTALLATION (MSB CUSTOM INTERFACE).....11  
     Attach Display to Centris Bracket.....11  
 CABLE MANAGEMENT .....12  
 ADJUST LATERAL TENSION .....12  
 ADJUST PITCH TENSION .....12

## TOOLS REQUIRED FOR INSTALLATION

- Electric drill and bit set
- Hex wrench set
- Phillips screwdriver
- Level

**NOTE:** Other tools may be required depending on your display, JWS configuration and method of installation.

## INSPECT UNIT BEFORE INSTALLING

**⚠ WARNING:** Watch for pinch points. Do not put your fingers between movable parts.

1. Carefully inspect mount for shipping damage. If any damage is apparent, call your carrier claims agent and do not continue with installation until carrier has reviewed damage.

**NOTE:** Read all instructions before starting installation.

2. Lay out components to ensure you have all required parts before proceeding (see PARTS on page 6). If you are missing any listed parts, contact Customer Service at: 1-800/582-6480.

## SPECIFICATIONS

**Table 1.** JWS Specifications

Depth from Wall	3.35" (85.07mm)
Maximum Extension	11.85" (300.97mm)
Dimensions W x H x D	13-1/8 x 11-1/12" x 3.35" (333 x 292.47 x 85.07mm)
Weight Capacity	75 lbs (34kg)

## INTRODUCTION

There are three main steps in the JWS-210 installation process. These steps are:

- Selecting an appropriate mounting configuration.
- Connect display cables
- Making required adjustments

Before starting the installation process, determine the correct mounting-hole configuration for your display by reviewing the information located within Table 2.

**NOTE:** If the displays mounting hole configuration does not match those identified at right, a custom MSB interface is required. Refer to a Chief Mfg. cross-reference or visit [www.chiefmfg.com](http://www.chiefmfg.com) to identify the appropriate MSB for your display.

### Reference Chart

Table 2 below provides a reference chart to help you determine the mounting-hole configuration of your display and quickly find the appropriate installation instructions.

**Table 2.** Installation Reference Chart

Screw Size	VESA Hole Pattern	Ref. Page
M4 x 12mm	100mm x 100mm (Flush Mount)	8
M4 x 20mm	100mm x 100mm (Recess Mount)	8
M4 x 16mm	200mm x 100mm	9
M4 x 20mm, M6 x 20mm M6 x 30mm OR M6 x45mm	200mm x 200mm	10
N/A	Non-VESA (Used with MSB Custom Interface bracket, purchased separately)	11

### Mounting-Hole Configurations

Figure 1 depicts the various mounting-hole configurations that are available to mount your display.

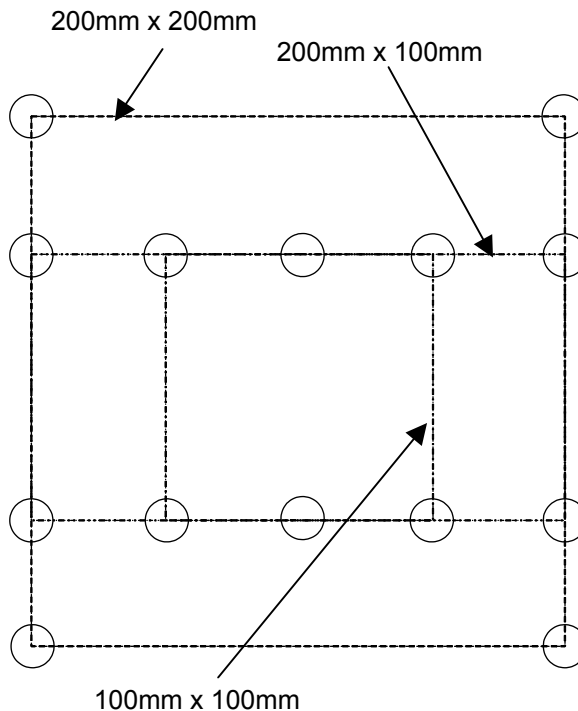

**Figure 1.** Typical VESA Mounting Hole Configurations

# COMPONENTS

Figure 2 shows the part and parts bags shipped with JWS.

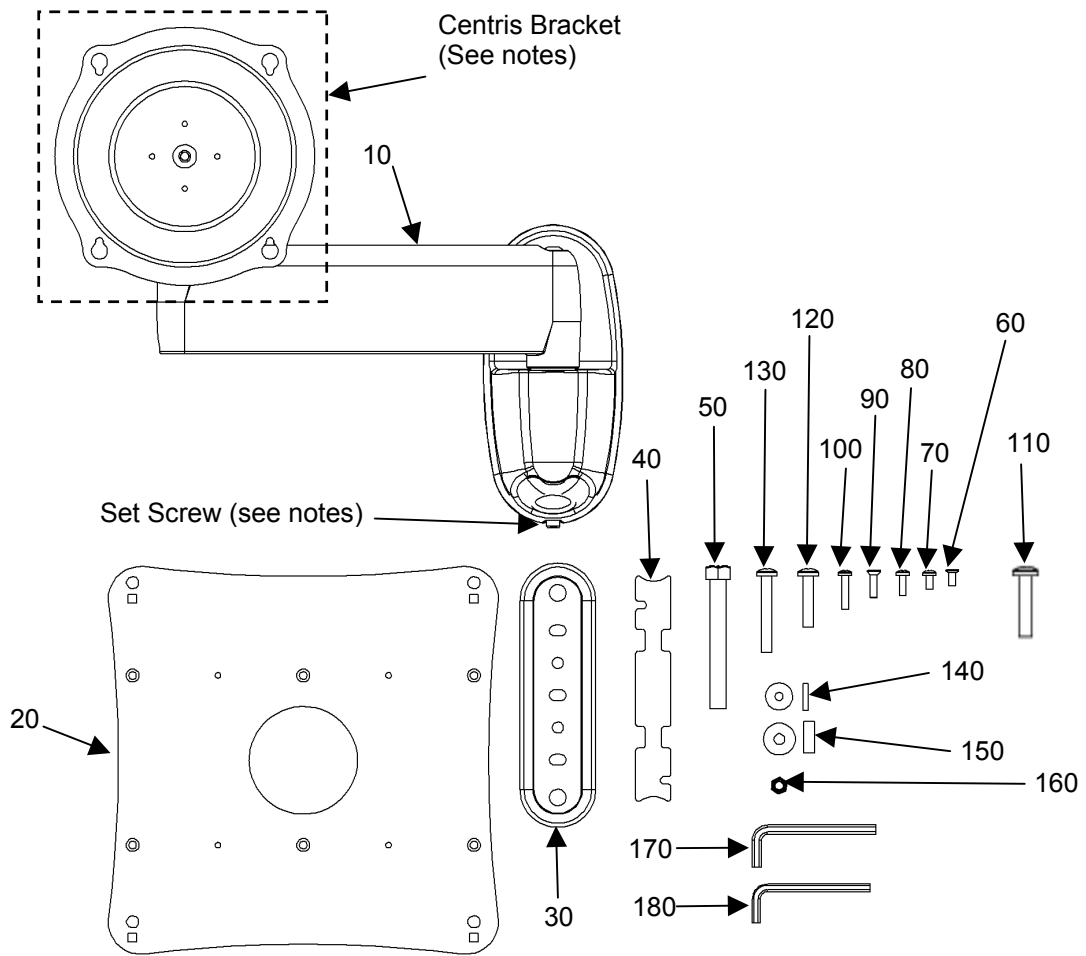

Figure 2. JWS Components

## PARTS

Table 3 shows the individual part and parts bags shipped with JWS parts.

**Table 3. JWS Parts List**

Item	Bag	Description	Qty	Notes
10	10	JWS MOUNT	1	See page 5 for graphic.
20	—	VESA Plate	1	Use with 70
30	—	Wall Bracket	1	Use with 50
40	—	Cable Management Bracket	1	Use with 60
50	—	Lag Screws, 3/8" x 3"	2	Use with 30
60	—	Phillips Pan Head Machine Screw, 8-32 x 3/8"	2	Use with 40
70	A	Phillips Pan Head Machine Screw, M4 X 8mm	4	Use with 20
80		Phillips Pan Head Machine Screw, M4 X 12mm	4	[Color Black] Use with Centris Interface
90		Phillips Flat Head Machine Screw, M4 X 16mm	6	Use with 140
100		Phillips Pan Head Machine Screw, M4 X 20mm	4	Use with 150
110	B	Phillips Pan Head Machine Screw, M6 X 20mm	4	Use with 150
120		Phillips Pan Head Machine Screw, M6 X 30mm	4	Use with 150
130		Phillips Pan Head Machine Screw, M6 X 45mm	4	Use with 150
140	C	Nylon Spacer, 1/8"	6	Use with 90
150		Nylon Spacer, 1/4"	4	Use with 110, 120, and 130
160	D	Nylock Nut, 10-24	4	Use with MSB
170		Hex Key, 5/32"	1	For Set Screw
180		Hex Key, 3/16"	1	For Tension Adjust.

## SECURE WALL BRACKET

**⚠ WARNING:** It is the responsibility of the installer to verify that the surface to which the mount is anchored will safely support the combined load of all attached components and equipment.

Install wall bracket as follows:

1. Determine exact mounting location prior to installation, considering unit's swing arm and extension radius.
2. Using wall bracket (30) as a template, mark two pilot holes (see Figure 3).
3. Drill two 1/4" pilot holes a minimum depth of 2" into wood stud.

**NOTE:** Make sure wall bracket is level before installing lag bolts. Do not over-tighten the lag bolts.

4. Using a 9/16" socket wrench, install two lag bolts (50) to wall.

## ATTACH MOUNT TO WALL BRACKET

**NOTE:** If display requires VESA 100mm X 100mm *recessed* mounting, you will need to install display onto mount before attaching mount to wall bracket. Proceed to "Recess Mount Centris Bracket to Display" on page 8.

To attach mount to wall bracket:

1. Align top of mount (10) with top of wall bracket (30). Push bottom of mount against bottom of wall bracket until mount fits snugly in place (see Figure 4).
2. Using 5/32" hex wrench (170), secure mount to wall bracket by tightening set screw (see Figure 5).

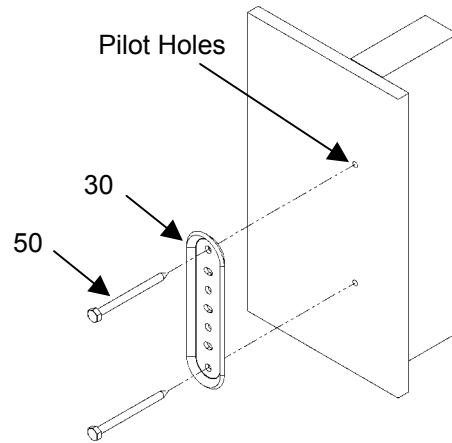

**Figure 3.** Secure Wall Bracket to Wall

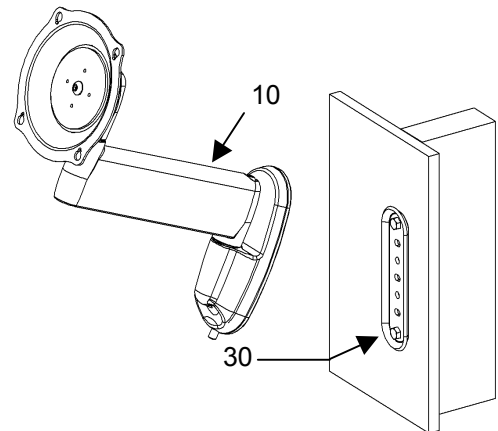

**Figure 4.** Attach Mount to Wall Bracket

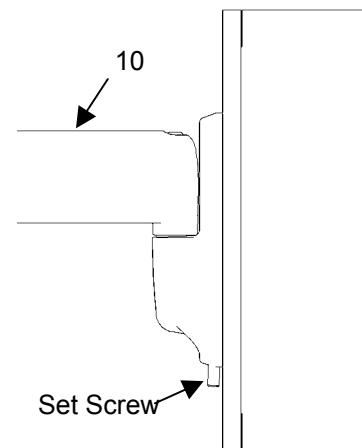

**Figure 5.** Tighten Set Screw

## INSTALLATION (100mm x 100mm)

### Flush Mount Centris Bracket to Display

To flush mount Centris Bracket:

1. Start two M4 x 12mm screws (80) into top mounting holes on display (see Figure 6).
2. Align mounting holes on Centris Bracket with screws installed on display. Hang display on Centris Bracket.
3. Install two remaining M4 x 12mm screws (80) into bottom mounting holes on display.
4. Tighten screws.
5. Proceed to "CABLE MANAGEMENT" on page 12.

### Recess Mount Centris Bracket to Display

To recess mount Centris Bracket:

1. Lay display down on a flat surface.

**⚠ CAUTION:** Make sure surface is clean and free of dirt and debris before laying display down.

2. Select four screws M4 x 20mm screws (100) and four spacers (150) from parts bag.
3. Place four spacers (150) over mounting holes on back of display (see Figure 7).
4. Align mounting holes on Centris bracket with spacers installed on display.
5. Install four screws M4 x 20mm screws (100) to attach Centris bracket to display (see Figure 7).
6. Tighten screws.
7. Refer to "ATTACH MOUNT TO WALL BRACKET" on page 7 for mount installation. After installing the mount on wall, refer to "CABLE MANAGEMENT" on page 12.

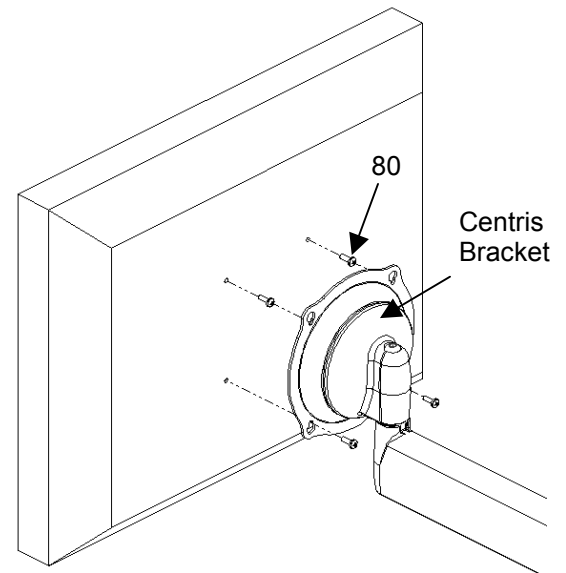

Figure 6. Flush Mount Centris Bracket to Display

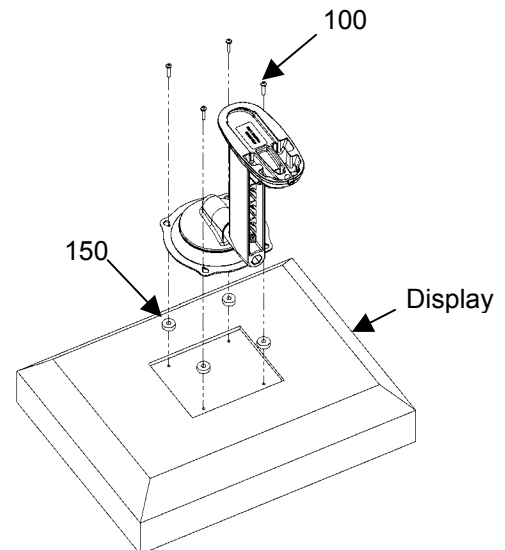

Figure 7. Recess Mount Centris to Display

## INSTALLATION (200mm x 100mm)

### Attach VESA Plate to Display

1. Lay display face down on a flat surface.

**CAUTION:** Make sure surface is clean and free of dirt and debris before laying display down.

2. Place six spacers (140) over six mounting holes in display as shown in Figure 8.
3. Attach VESA Plate (20) to display using six M4 x 16mm flat head screws (90).
4. Tighten screws.

### Attach Display to Centris Bracket

1. Start two M4 x 8mm Phillips pan head screws (70) into top mounting holes on interface bracket (20).
2. Align mounting holes on Centris Bracket with screws installed in Step 1 (see Figure 9).
3. Install remaining two M4 x 8mm Phillips pan head screws (70) into bottom mounting holes of Interface Bracket (20).
4. Tighten screws.
5. Proceed to "CABLE MANAGEMENT" on page 12.

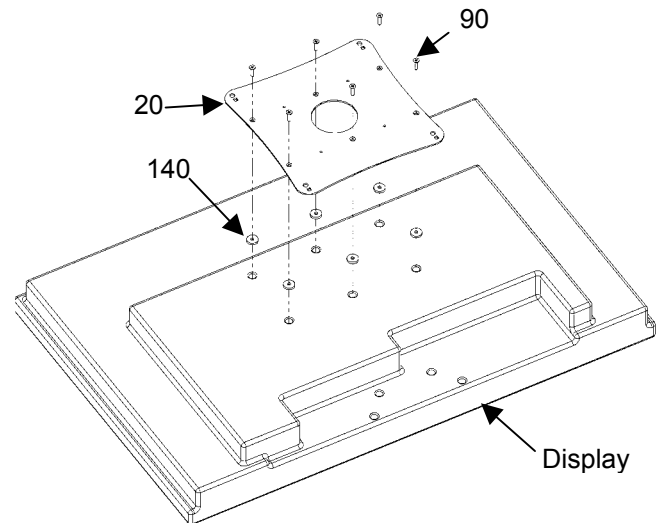

**Figure 8.** Attach Interface Bracket to Display  
(200mm x 100mm)

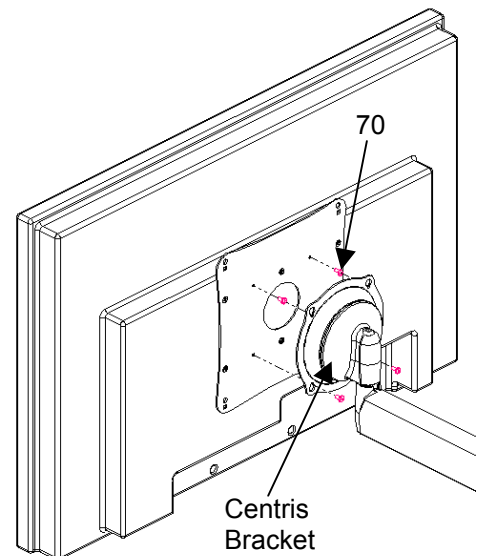

**Figure 9.** Attach Display to Centris Bracket

# INSTALLATION (200mm x 200mm)

**⚠ WARNING:** It is the responsibility of the installer to use the correct diameter and length of fastener to attach interface to back of display. Failure to do so may cause damage to the display or personal injury.

## Attach VESA Plate to Display

1. Lay display face down on a flat surface.

**NOTE:** Make sure surface is clean and free of dirt and debris before laying display down.

2. Place four spacers (150) over four mounting holes in display as shown in Figure 10.
3. Depending on mounting hole size and depth, attach VESA Plate (20) by selecting applicable screws size, as follows (see Figure 11):
  - a. Use four M4 x 20mm pan head screws (100) and square holes to attach VESA Plate (20). Or,
  - b. Use four M6 x 20mm pan head screws (110) and round holes to attach VESA Plate (20). Or,
  - c. Use four M6 x 30mm pan head screws (120) and round holes to attach VESA Plate (20). Or,
  - d. Use four M6 x 45mm pan head screws (130) and round holes to attach VESA Plate (20).
4. Tighten screws.

## Attach Display to Centris Bracket

1. Start two M4 x 8mm Phillips pan head screws (70) into top mounting holes on VESA Plate (20). See Figure 12.
2. Align mounting holes on Centris bracket with screws installed in Step 1.
3. Install two remaining M4 x 8mm Phillips pan head screws (70) through bottom mounting holes of Centris bracket, and into VESA Plate (20).
4. Tighten screws.
5. Proceed to "CABLE MANAGEMENT" on page 12.

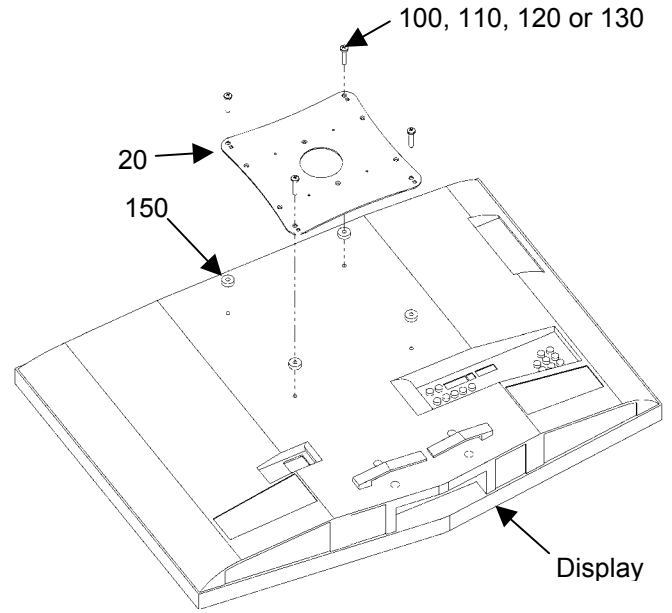

Figure 10. Attach Interface Bracket to Display

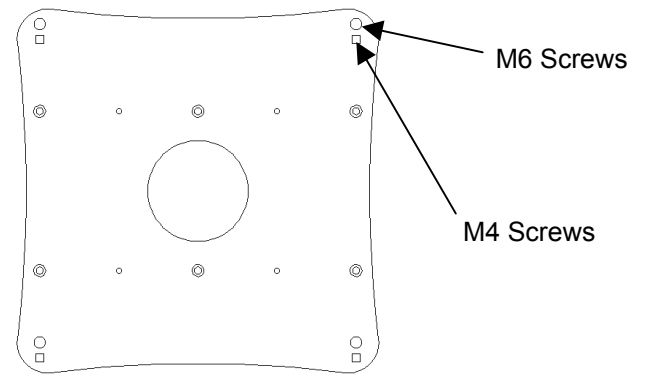

Figure 11. VESA Plate Mounting Holes

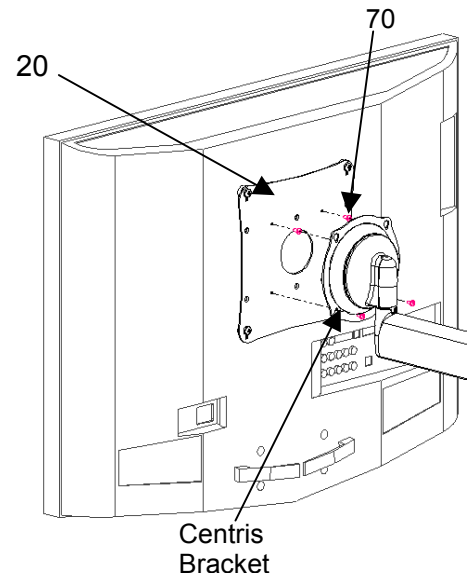

Figure 12. Mount Display to Centris Bracket

# INSTALLATION

## (MSB CUSTOM INTERFACE)

### Attach Display to Centris Bracket

**NOTE:** Many MSB Custom Interface brackets require the use of the VESA Plate (20) and the 10-24 nylock nuts shipped with this mount. Follow specific instructions received with the MSB Custom Interface to install the MSB to back of display.

1. Start two M4 x 8mm Phillips pan head screws (70) into top mounting holes of VESA Plate (20) or MSB interface bracket, depending on configuration (see Figure 13 or Figure 14).
2. Align mounting holes on Centris bracket with screws installed in MSB or VESA Plate in Step 1.
3. Hang display on Centris bracket (see Figure 15).
4. Install two remaining M4 x 8mm Phillips pan head screws (70) into bottom two mounting holes of MSB or VESA Plate (20).
5. Tighten screws.
6. Proceed to "CABLE MANAGEMENT" on page 12.

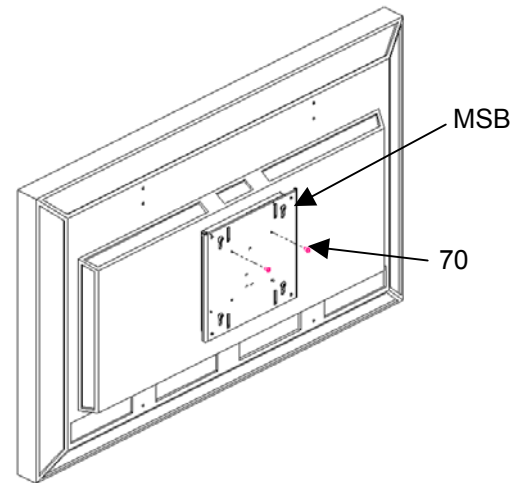

**Figure 13.** MSB without VESA Plate

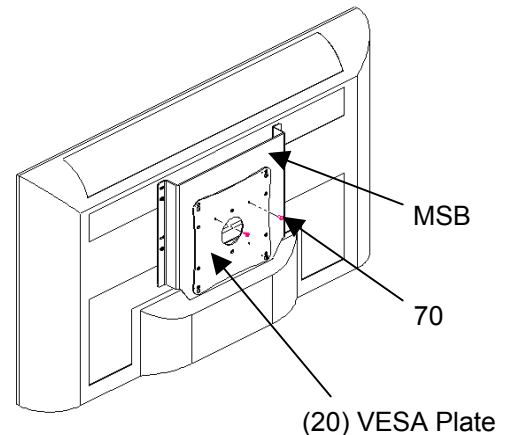

**Figure 14.** MSB with VESA Plate

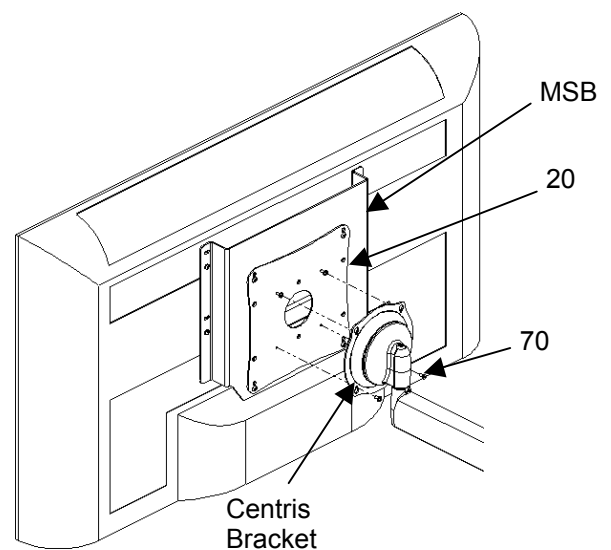

**Figure 15.** Mount MSB to Centris Bracket

## CABLE MANAGEMENT

**⚠ WARNING:** Make sure your cables do not run through any pinch points. Do not put your fingers between movable parts.

To route and manage cable(s):

1. Connect and secure power/audio/video cables, making sure to leave sufficient slack to allow for movement of display.
2. Route power/audio/video cables under/in each arm, allowing sufficient slack in cables for extension and avoiding pinch points.
3. Secure cables using cover plate (40) and two screws (60). See Figure 16.

**NOTE:** If cables are too large to fit inside arms, use zip ties (not supplied) to attach cables to bottom of cover plate (40).

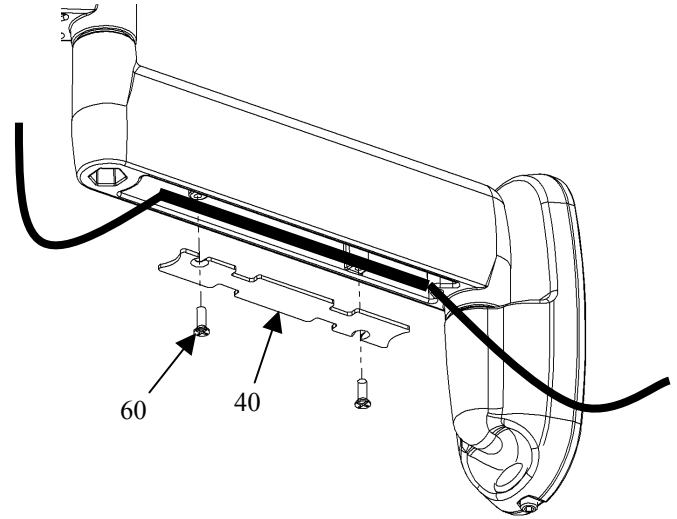

**Figure 16.** Cable Management

## ADJUST LATERAL TENSION

To adjust Lateral Tension:

1. Move arms laterally to check for desired tension.
2. Using a 3/16" hex wrench slightly tighten or loosen lateral tension adjustment bolts (see Figure 17).
3. Repeat Steps 1 and 2 until desired tension is obtained.

## ADJUST PITCH TENSION

To adjust Pitch Tension:

1. Tilt display to check for desired tension.
2. If pitch tension in Centris Bracket requires adjustment, perform the following steps:
  - a. Remove Display from Centris Bracket.
  - b. Using a 3/16" hex wrench, slightly tighten or loosen pitch adjustment bolt to adjust Centris bracket as needed (see Figure 17).
  - c. Reinstall display.
3. Repeat Steps 1 and 2 until desired tension is obtained.

Lateral Tension Adjustment Bolt

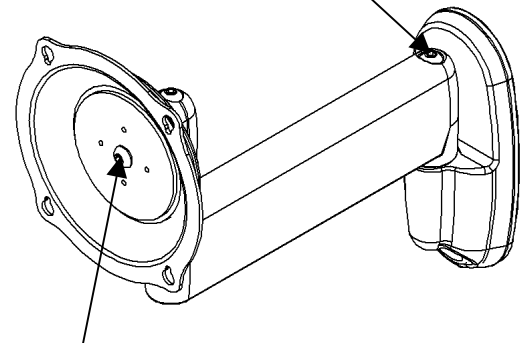

Pitch Adjustment Bolt

**Figure 17.** Adjust Lateral and Pitch Tension