INSTALLATION INSTRUCTIONS

LARGE FLAT PANEL DISPLAY STATIC MOUNT PST 2000 Series

The PST static wall mount accommodates large flat screens weighing up to 200 lbs (90.72kg). The teardrop holes in the mount allow for quick connect/disconnect of the screen, thus simplifying installation and maintenance processes.

The top and bottom mounting brackets are adaptable to supporting framework with wood studs that are 16" on center or 24" on center.

The mount has integrated lateral shift, allowing for four different mounting options. For dual wood studs 16" on center, the lateral shift is ± 4.5 inches. For dual wood studs 24" on center, the lateral shift is ± 0.5 inches.

After installing the flat screen on the mount, the screen can be locked in place using the convenient locking flag. A padlock can be used on the latching flag for added security.

The mount is concealed behind the display, making it a low profile wall mount.

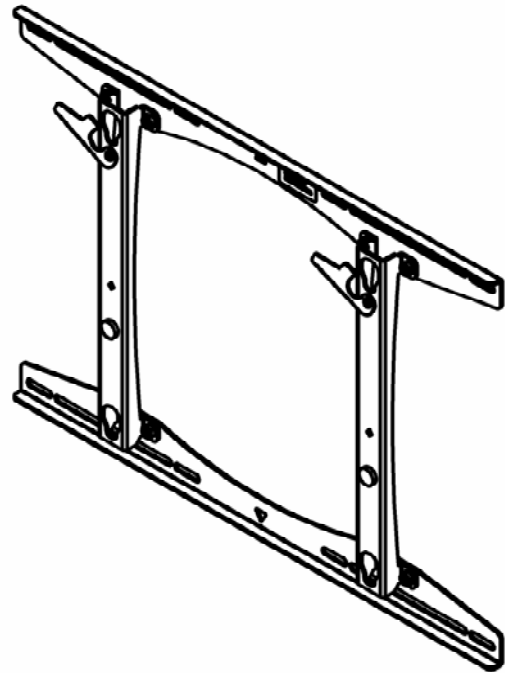

PST 2000 Series

! IMPORTANT: If the installation of this product requires OSHPD seismic approval, refer to OSHPD pre-approval documents and drawings before beginning installation. OSHPD documents and drawings are available at www.chiefmfg.com, and located on the product information page for the mount.

BEFORE YOU BEGIN

- **CAUTION:** To prevent damage to the mount, which could affect or void the Factory warranty, thoroughly study all instructions and illustrations before you begin to install the mount brackets. Pay particular attention to the "Important Warnings and Cautions" on Page 2.
- The mount is designed to be installed using wall studs or supporting framework. The fasteners used to anchor the mount must be capable of supporting five times the total weight of the equipment.
- The maximum weight to be installed on the PST mount is 200 lbs (90.72kg).
- If you have any questions about this installation, contact Chief Manufacturing at 1-800-582-6480 or 952-582-6480.



CHIEF MANUFACTURING INC.
1-800-582-6480 952-894-6280 FAX 952-894-6918
8401 EAGLE CREEK PARKWAY, STE. 700
SAVAGE, MINNESOTA 55378 USA

8804-000255 (Rev. C)
©2005 Chief Manufacturing
www.chiefmfg.com
11/05

! IMPORTANT WARNINGS and CAUTIONS!

- WARNING** A **WARNING** alerts you to the possibility of serious injury or death if you do not follow the instructions.
- CAUTION** A **CAUTION** alerts you to the possibility of damage or destruction of equipment if you do not follow the corresponding instructions.
- **WARNING** **Improper installation can result in serious personal injury! Make sure that the mounting surface can support a redundant weight factor *five times* the total weight of the equipment: if not, reinforce the structure before installing the mount.**
- **WARNING** **Be aware of the potential for personal injury or damage to the unit if it is not adequately mounted.**
- **WARNING** **The installer is responsible for verifying that the wall to which the mount is anchored will safely support the combined load of all attached components or other equipment.**
- **WARNING** **The weight of the large flat screens must not exceed 200 lbs (90.72kg), the maximum load capacity of the mount.**
- **WARNING** **Watch for pinch points. Do not put your fingers between movable parts.**
- **WARNING** **Make sure the flag securing the display is completely lowered at all times *except* when removing or installing the display. The flag must be all the way down when installing/removing cables**
- **CAUTION** **Inspect the unit for shipping damage before you begin the installation.**

DIMENSIONAL DRAWING

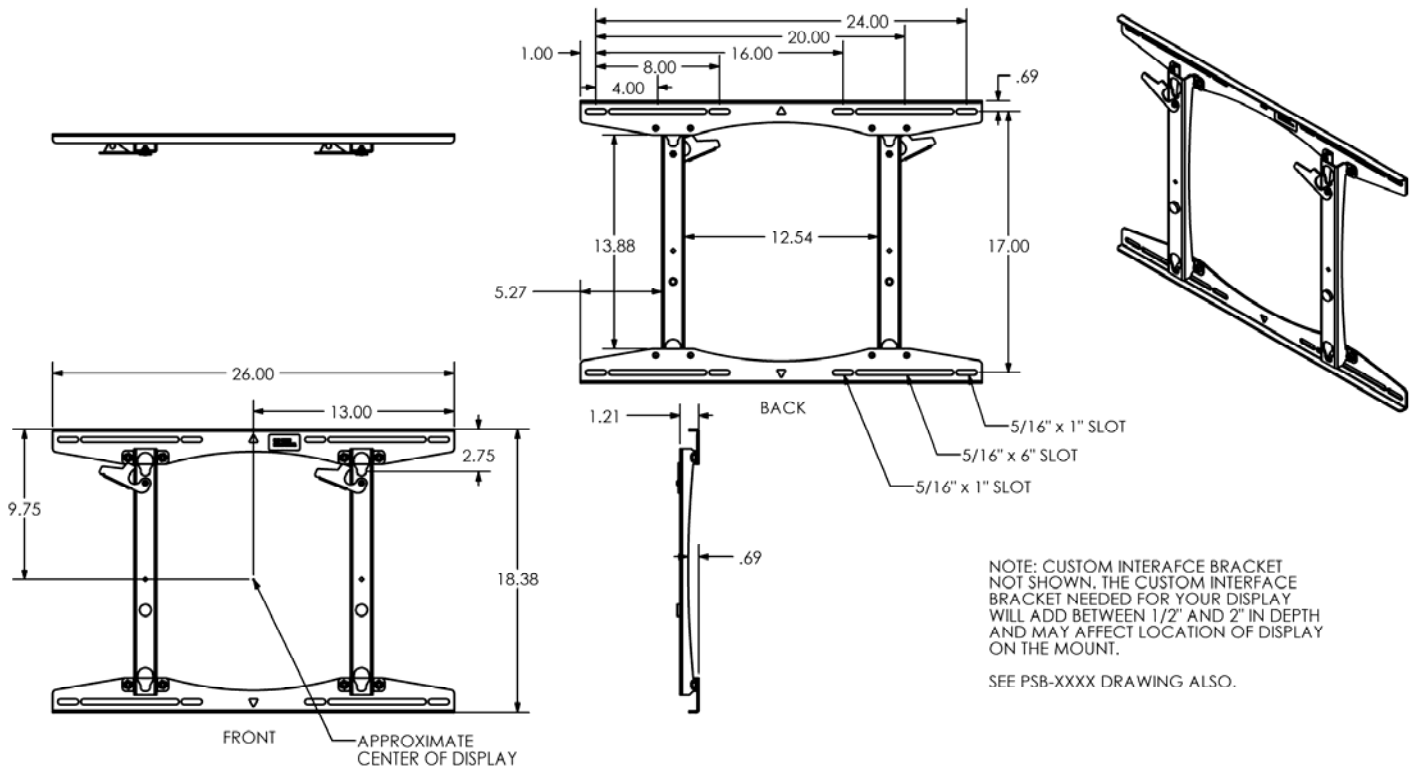

CONTENTS

DIMENSIONAL DRAWING.....2
 TOOLS REQUIRED FOR INSTALLATION3
 PARTS LIST3
 PST INSTALLATION.....4
 Select Mounting Location4
 Mount the PST.....5
 ATTACH PSB TO THE DISPLAY6
 INSTALL THE DISPLAY6
 REMOVE THE DISPLAY6

TOOLS REQUIRED FOR INSTALLATION

- Drill and drill bit set
- Socket wrench set

NOTE: Other tools may be required depending on your method of installation.

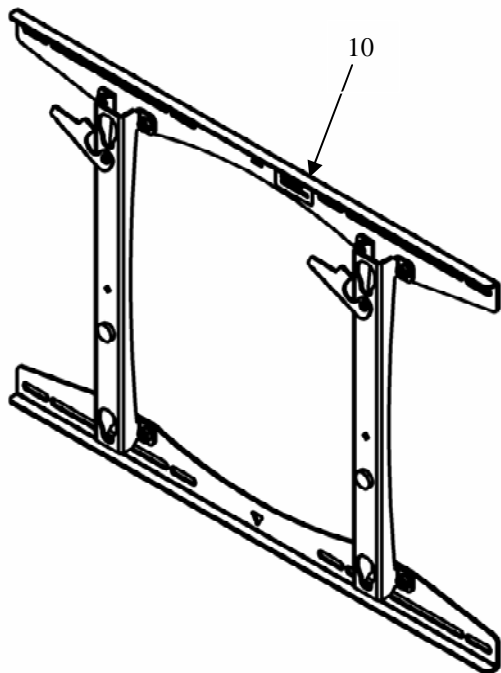

PARTS LIST

Prior to assembly, unpack the carton completely. Verify contents listed in Table 1 and Figure 1.

Read installation instructions completely. If you are missing any of the listed parts, contact Customer Service at: 1-800/582-6480.

Table 1. Parts List

REF	DESCRIPTION	QTY
10	Plasma Static Mount	1
—	Lag Bolts, 5/16” x 2 1/2” (required, not supplied)	4
—	Flat Washer, 5/16” (required, not supplied)	4

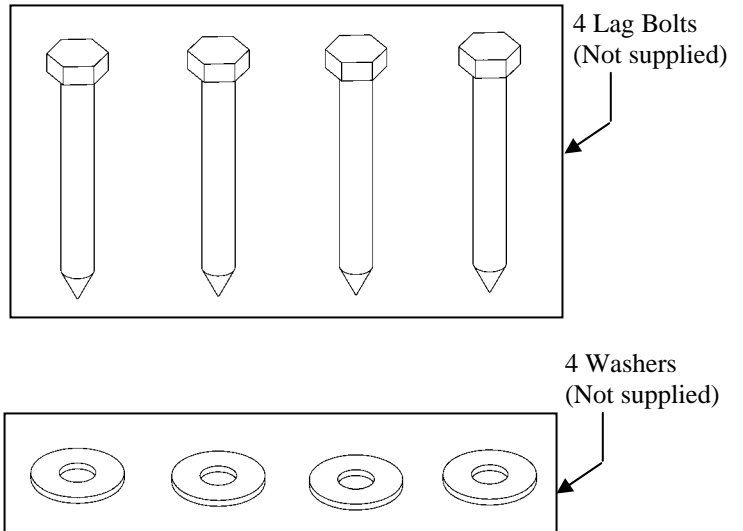

Figure 1. Parts

PST INSTALLATION

Perform the following procedures to mount the PST.

Select Mounting Location

To select the mounting location, do the following:

WARNING: It is the responsibility of the installer to verify that the wall to which the mount is anchored will safely support the combined load of all attached components and equipment.

1. Determine the exact mounting location to install the wall mount prior to installation, keeping in mind the screen size.

NOTE: Mount the PST on dual wall studs or some other equivalent supporting framework that is vertical or horizontal.

2. Using a stud sensor, locate the two wood studs where you will mount the PST, as follows:
 - Refer to Figure 3 for dual wood studs that are 16" apart on center.

OR

- Refer to Figure 4 for dual wood studs that are 24" apart on center.
3. Using a nail as a temporary hook, hang the mount on the wall using the triangular hole located in the center of the mount (see Figure 2).
 4. Use a pencil to mark the mounting holes where the four pilot holes will be drilled into the center of the wood stud. Make sure the mounting holes are square and straight. Remove the mount from the wall, placing it on the floor or a table.

NOTE: Lag bolts are not supplied.

5. Drill the pilot holes using a 7/32" drill bit.

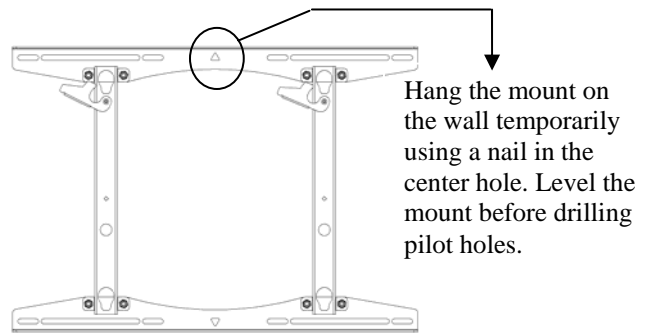

Figure 2. Use Triangular Hole to Hang the Mount

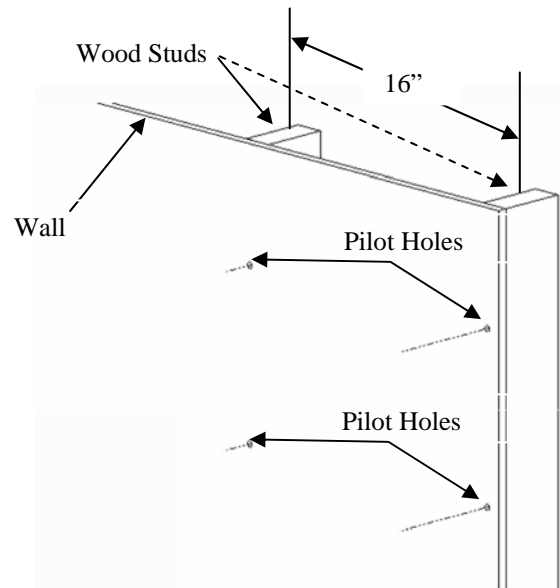

Figure 3. Wood Studs 16" Apart on Center

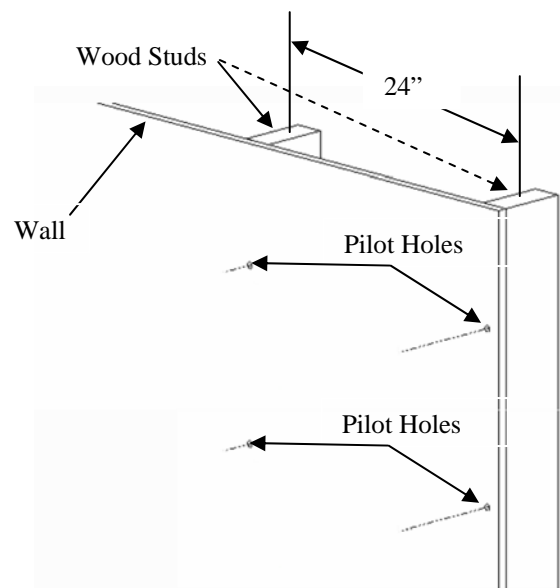

Figure 4. Wood Studs 24" Apart on Center

PST INSTALLATION (Cont'd)

Mount the PST

To mount the PST, do the following:

1. Holding the PST against the wall, select the pair of mounting holes that best suits your situation (see Figures 5, 6, and 7).

NOTE: The mounting holes are slotted to allow for a small degree of lateral movement. The mount can be centered, or shifted to the left of center, or right of center depending on stud location.

NOTE: Lag bolts and washers are not supplied.

2. Depending on your situation, install the lag bolts and washers into the pilot holes previously drilled, as described below.

- **Option A.** Install four 5/16" x 2 1/2" lag bolts and four 5/16" washers (two top and two bottom) into the mounting holes, centering the PST on dual wood studs 16" apart on center as shown in Figure 5.

OR

- **Option B.** Install four 5/16" x 2 1/2" lag bolts and four 5/16" washers (two top and two bottom) into the mounting holes that are *right of center* on dual wood studs 16" apart as shown in Figure 6.

OR

- **Option C.** Install four 5/16" x 2 1/2" lag bolts and four 5/16" washers (two top and two bottom) into the mounting holes that are *left of center* on dual wood studs 16" apart on center as shown in Figure 6.

OR

- **Option D.** Install four 5/16" x 2 1/2" lag bolts and four 5/16" washers (two top and two bottom) into the mounting holes, centering the PST on dual wood studs 24" apart on center as shown in Figure 7.

3. Tighten all lag bolts.

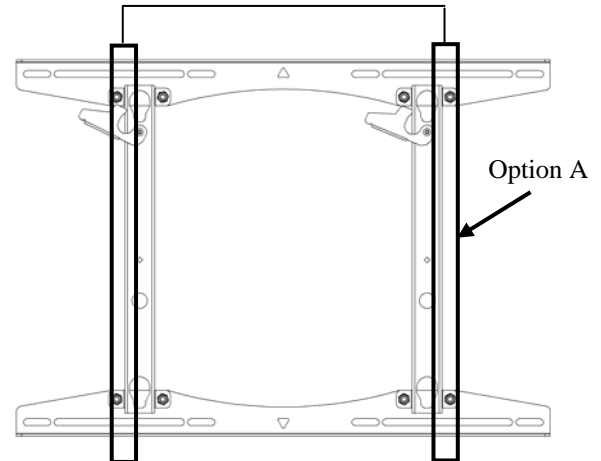

Figure 5. Mounting Holes – 16" Apart on Center (Option A)

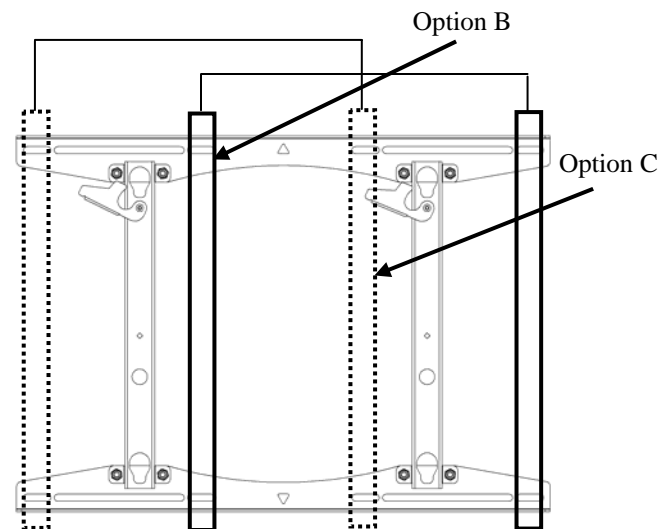

Figure 6. Mounting Holes – 16" Apart on Center (Options B and C)

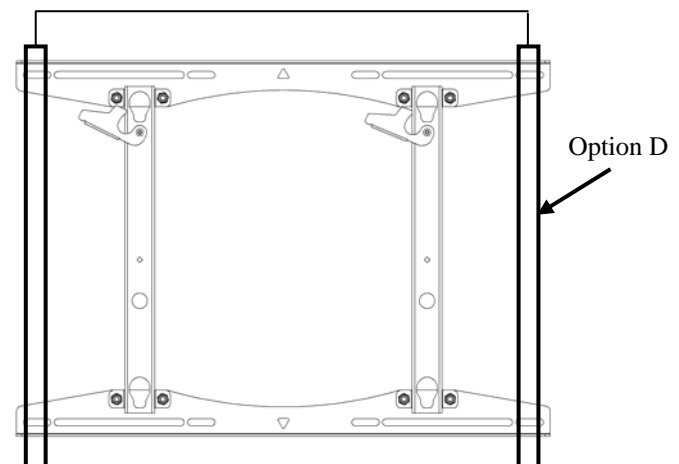

Figure 7. Mounting Holes – 24" Apart On Center (Option D)

ATTACH PSB TO THE DISPLAY

To attach the PSB to the display, do the following:

- To help you identify the correct PSB that matches the model number of your display, refer to the cross-reference chart at www.chiefmfg.com.
- To download the corresponding PSB installation instructions, refer to www.chiefmfg.com.

OR

- Contact Customer Service at 952-582-6480 if you have any questions about how to select the PSB that matches the model number of your display.

INSTALL THE DISPLAY

To install the display, do the following:

NOTE: Verify that all power/audio/video cables are disconnected from the display and the latching flag is lowered in the down position before attempting to mount the display.

1. With the aid of another person, lift the display up to the mount (10) on the wall, aligning mounting buttons on the PSB with the teardrop slots on the mount, and lower the display firmly into place (Figure 8).
2. Raise the latching flag (2 places) to secure the display (see Figure 9). If the flag does not fully engage, check to ensure the mounting buttons are fully seated in the slots.

NOTE: A padlock may be installed through the hole in the latching flag for additional security.

REMOVE THE DISPLAY

To remove the display from the mount, do the following:

1. Disconnect all power/audio/video cables.
2. Lower the latching flag to unlock the display (see Figure 10).
3. With the aid of another person, lift the display up and out of the teardrop slots in the mount to remove the display.

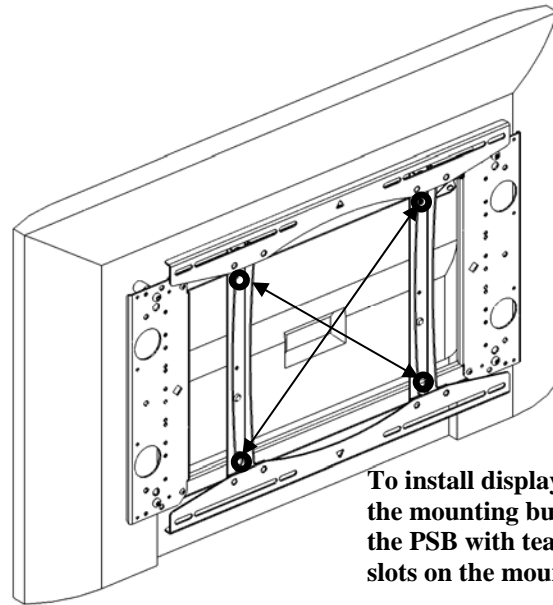

To install display, align the mounting buttons on the PSB with teardrop slots on the mount.

Figure 8. Mount Plasma Static Bracket to Wall

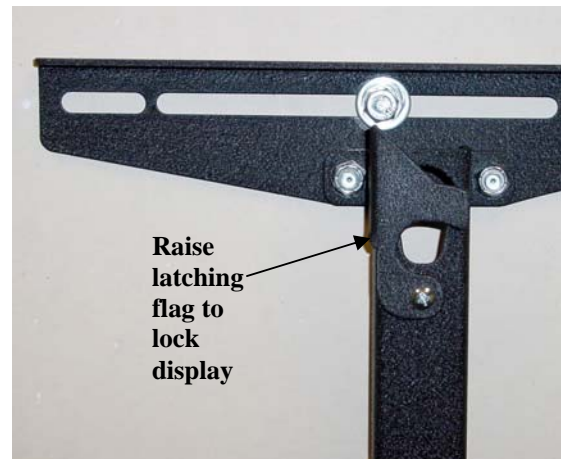

Figure 9. Raise Latching Flag to Lock

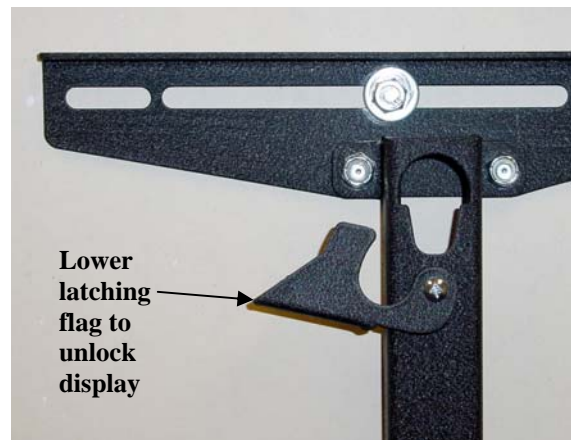

Figure 10. Lower Latching Flag to Unlock