

---

# INSTALLATION INSTRUCTIONS

---

## Small Flat Panel Height-Adjustable Triple Swing Arm Wall Mount (FWB-110)

The FWB is a sleek design providing a broad range of viewing for Small Flat Panel Displays.

The FWB triple swing arm desk mount easily rotates laterally. The lift arm has 13 inches of vertical travel, 6-1/2" up from center and 6-1/2" down from center.

On standard installations, the FWB is wall-mounted.

The mount will safely hold a display weighing up to 25 lbs. (11.3 kg) maximum. The display can be up to 30 inches wide.

The FWB accommodates all VESA® 75mm/100mm compliant displays.

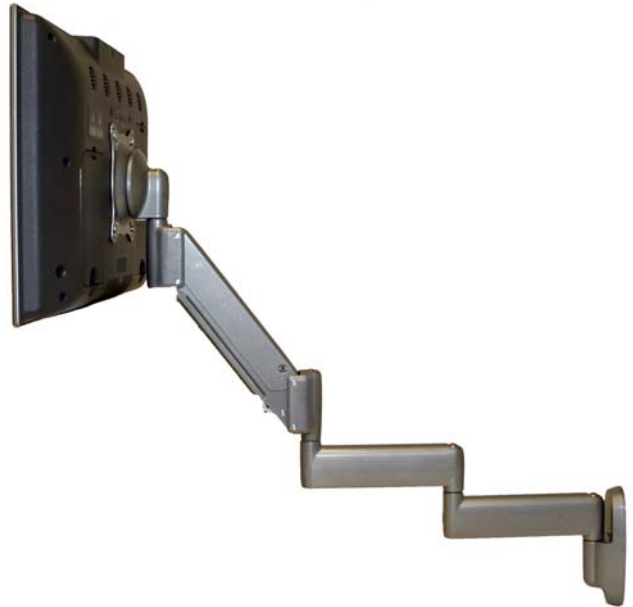

### BEFORE YOU BEGIN

- **CAUTION:** To prevent damage to the mount, which could affect or void the Factory warranty, thoroughly study all instructions and illustrations before you begin to install the mount brackets. Pay particular attention to the "Important Warnings and Precautions" on Page 2.
- If you have any questions about this installation, contact Chief Manufacturing at 1-800-582-6480 or 952-582-6480.



## IMPORTANT WARNINGS and CAUTIONS!

- WARNING** A **WARNING** alerts you to the possibility of serious injury or death if you do not follow the instructions.
- CAUTION** A **CAUTION** alerts you to the possibility of damage or destruction of equipment if you do not follow the corresponding instructions.
- **WARNING** Improper installation can result in serious personal injury! Make sure that the mounting surface can support a redundant weight factor *five times* the total weight of the equipment: if not, reinforce the mounting surface structural members before installing the FWB.
  - **WARNING** Be aware of the potential for personal injury or damage to the unit if it is not adequately mounted.
  - **WARNING** The installer is responsible for verifying that the mounting surface to which the FWB is anchored will safely support the combined load of all attached components or other equipment.
  - **WARNING** The combined weight of the display placed on the FWB must not exceed 25 lbs. (11.3kg), the maximum load capacity of the mount.
  - **WARNING** Watch for pinch points. Do not put your fingers between movable parts.
  - **WARNING** Make sure the mount is correctly oriented.
  - **CAUTION** Check the unit for shipping damage before you begin the installation.
  - **CAUTION** Over-tightening mounting screws may damage your display.

## CONTENTS

TOOLS REQUIRED FOR INSTALLATION.....	2
DRAWING .....	3
Installation .....	4
Flushed Mount or Recessed Mount .....	4
Flushed Mount.....	4
Recessed Mount.....	4
Cable Connection.....	5
Spherical, Arm, and Lateral Movement Tension Adjustment .....	5
Lift Arm Tension Adjustment .....	5

## TOOLS REQUIRED FOR INSTALLATION

- Phillips screwdrivers, No. 1 and No. 2
- 3/16" Allen wrench
- Drill and drill bits

**NOTE:** Other tools may be required depending on your method of installation.

# DRAWING

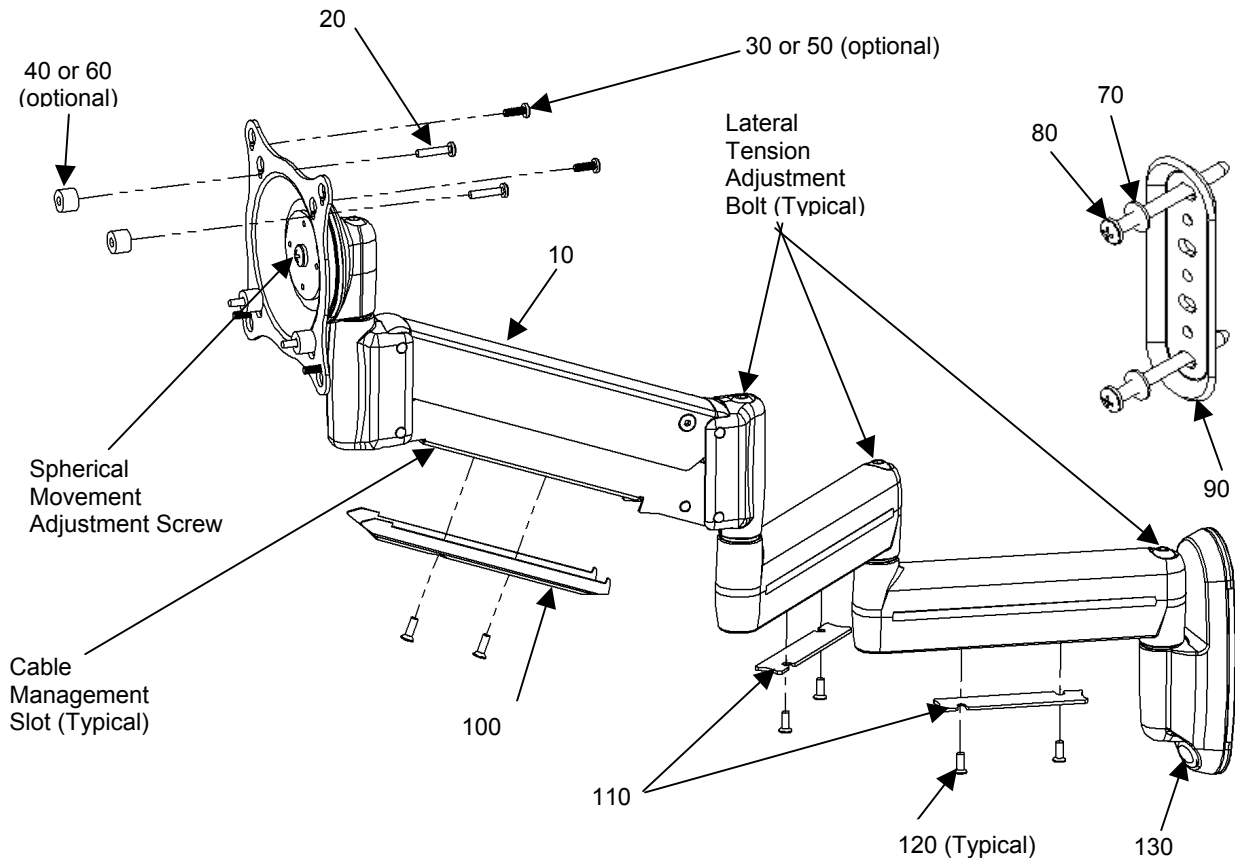

PART	PART NAME	QTY	NOTES
10	TRIPLE ARM WALL HEIGHT-AJUSTABLE	1	
20	SCREW, PHILLIPS PAN HEAD, M4 x 12MM	4	FLUSH MOUNT
30	SCREW, PHILLIPS PAN HEAD, M4 x 20MM (USE WITH 40) *	4	RECESSED MOUNT
40	3/8" SPACER	4	
50	SCREW, PHILLIPS PAN HEAD, M4 x 30MM (USE WITH 60) **	4	
60	3/4" SPACER	4	
70	WASHER	2	
80	SCREW, SELF-TAPPING	2	
90	BRACKET, WALL	1	
100	LIFT ARM PLATE, COVER, CABLE MANAGEMENT	1	
110	SWING ARM PLATE, COVER, CABLE MANAGEMENT	2	
120	SCREW, COVER, CABLE MANAGEMENT	6	
130	SCREW, SET	1	NOT SHOWN

- \*Use M4 x 20mm screws (30) with spacers (40) for recessed applications.
- \*\*Use M4 x 30mm screws (50) with spacers (60) for recessed applications.

## Installation

### Step 1

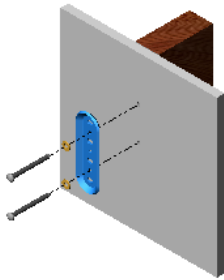

- A. Determine the exact mounting location prior to installation, considering screen size as well as the mount swing and extension radius.
- B. Use the wall bracket (90) as a template and drill two 3/32" pilot holes to a minimum depth of 1 1/2".
- C. Check wall bracket to ensure it is level and adjust to level if necessary.
- D. Use two self-tapping screws (80) and two #10 washers (70) to secure the wall bracket (90).

### Step 2

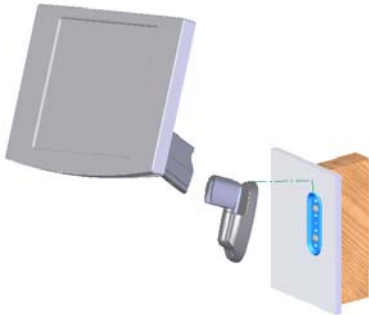

## Flushed Mount or Recessed Mount

**NOTE:** This manual contains two sets of Installation Instructions, listed below. Choose the set of instructions that applies to the type of installation you want.

- Flush Mount Applications do not use spacers. The monitor is attached to the mount with four screws.
- Recessed Mount Applications use spacers. The monitor is attached to the mount with four screws and four spacers.

**CAUTION:** If monitor uses a screw size other than those included in the kit, DO NOT use the screws provided. Using the wrong screws could result in damage to your monitor.

### Flushed Mount

- A. Install two screws (20) in to the top mounting holes of your monitor.
- B. Align the hole-pattern of your display with the screws installed on the mount and hang the mount from the two screws.
- C. Install two remaining screws (20) through the mount and into the mounting holes of your display.

### Step 3

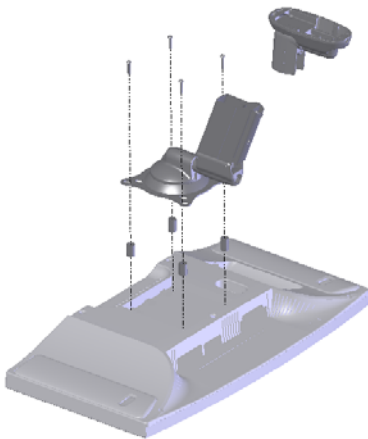

### Recessed Mount

**NOTE:** Use one of the following screw and spacer combinations: (30 with 40) or (50 with 60).

- A. Select four screws (30 or 50) for the Recessed mount application.
- B. Select the four spacers (40 or 60) for the Recessed mount application.
- C. Set four spacers (40 or 60) over the four mounting holes on your monitor.
- D. Install two screws (30 or 50) in to the top mounting holes of your monitor.
- E. Align the hole-pattern of your display with the screws installed on the mount and hang the mount from the two screws.
- F. Install two remaining screws (30 or 50) through the mount and into the mounting holes of your display.

## Cable Connection

1. Place the top of the mount on top of the wall bracket (90) and push the bottom onto the wall bracket.
2. Secure your display to the wall by tightening the set screw (130).  
**CAUTION:** Make sure your cables do not run through a pinch point.
3. Connect and secure power/audio/video cables, making sure to leave sufficient slack to allow for movement of the display. Secure cables using cover plates (100 and 110) and screws (120).

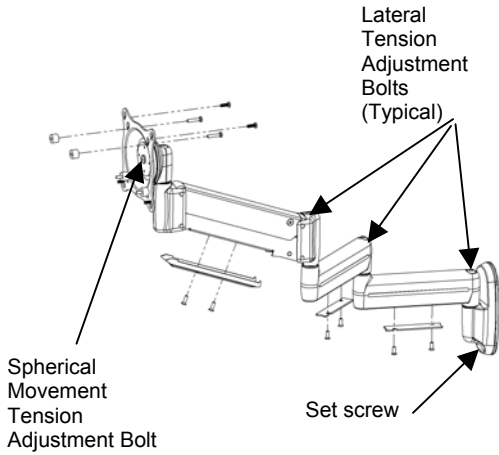

## Spherical, Arm, and Lateral Movement Tension Adjustment

**CAUTION:** Over-tightening adjustment bolt will cause excessive wear and may distort adjustment components.

To adjust the tension of the spherical movement, the arm movement, and the lateral movement:

1. Slightly tighten or loosen the tension adjustment bolt indicated at the right.
2. Check for desired tension.
3. Repeat as necessary.

## Lift Arm Tension Adjustment

**CAUTION:** Over-tightening tension bolt will cause excessive wear and may distort adjustment components.

To adjust the tension of the lift arm:

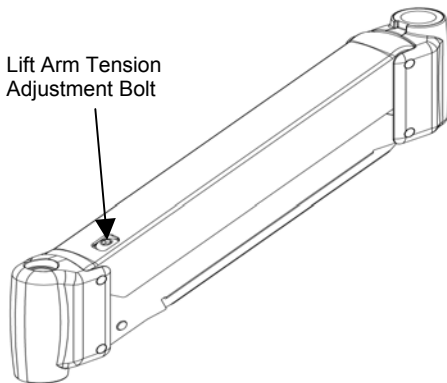

1. Raise or lower the lift arm until tension adjustment bolt appears in the opening.
2. Adjust the tension adjustment bolt, using a 3/16" Allen wrench, as follows:
  - a. To increase lift arm tension, turn the tension adjustment bolt one to two turns counterclockwise.
  - b. To decrease lift arm tension, turn the tension adjustment bolt one to two turns clockwise.
3. Raise or lower the lift arm to check for desired tension. Repeat step 2 as needed.