

# CS/503 *Eleven*

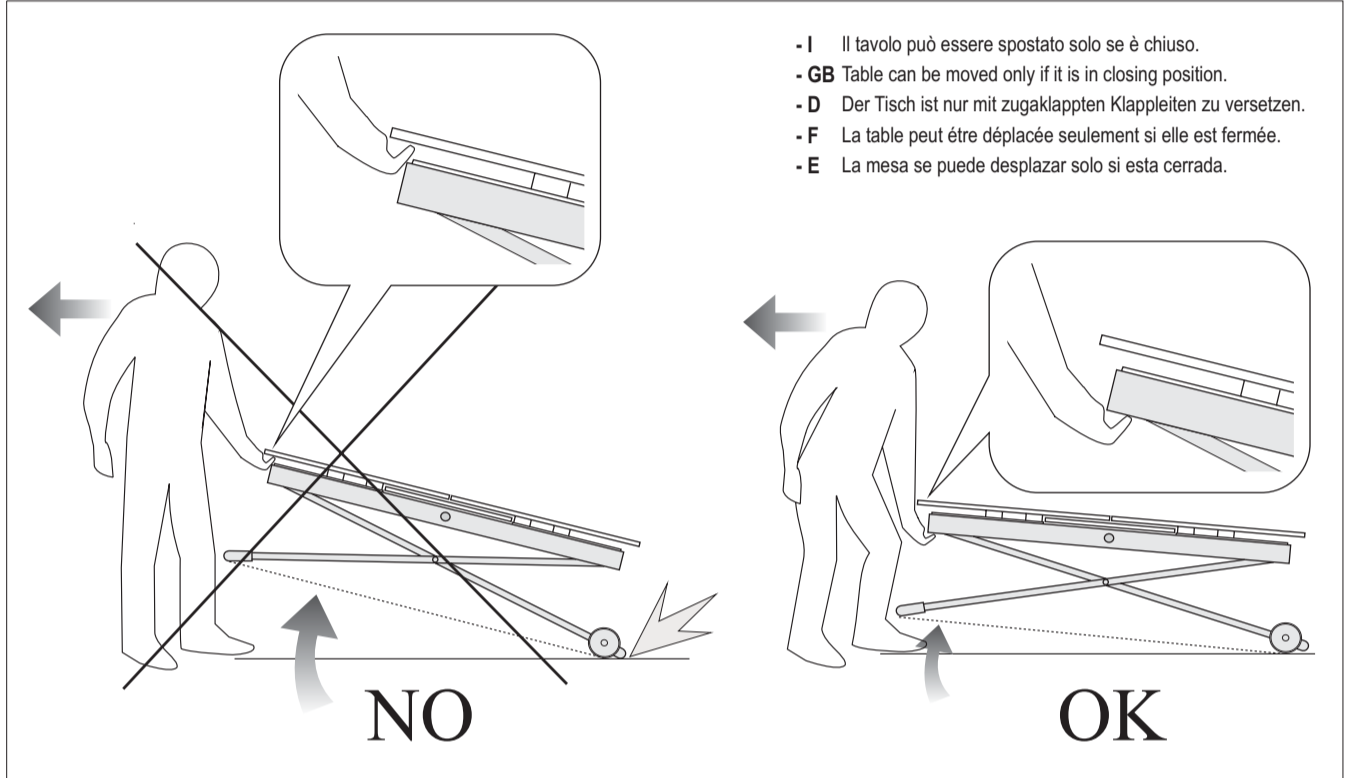

- I Pezzo di ricambio.
- GB Spare part.
- D Ersatzteil.
- F Pièce en échange / s.a.v.
- E Repuesto

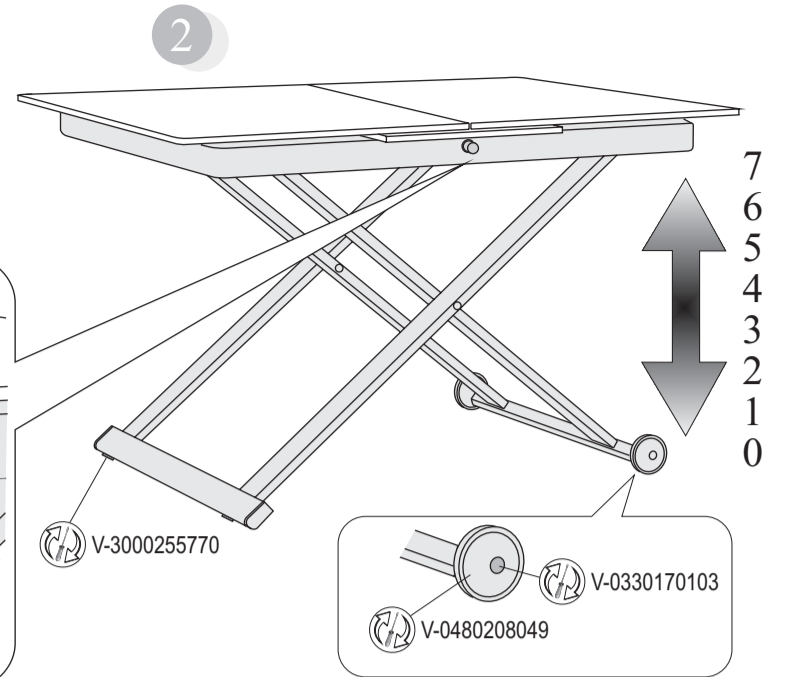
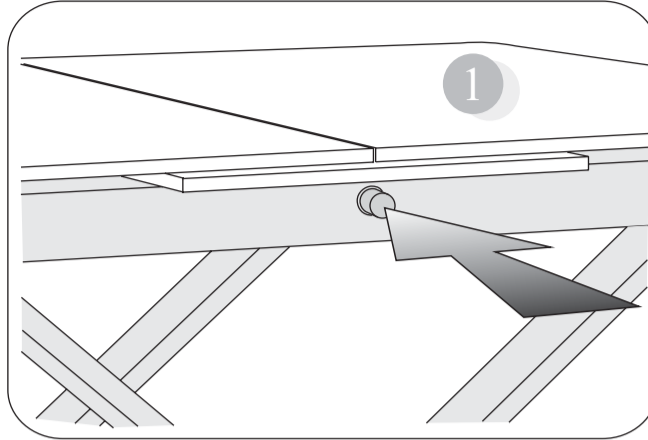

- I Il tavolo può essere spostato solo se è chiuso.
- GB Table can be moved only if it is in closing position.
- D Der Tisch ist nur mit zugaklappten Klappleitern zu versetzen.
- F La table peut être déplacée seulement si elle est fermée.
- E La mesa se puede desplazar solo si esta cerrada.



Calligaris s.p.a. - 33044 Manzano (Udine) Italy - Viale Trieste, 12  
Tel. +39.0432.748211 - Fax +39.0432.750104  
<http://www.calligaris.it> e-mail: [info@calligaris.it](mailto:info@calligaris.it)

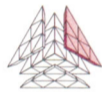

Quality System UNI EN ISO 9001 Associato assArredo

H.A. 503 01 00-0

## Open

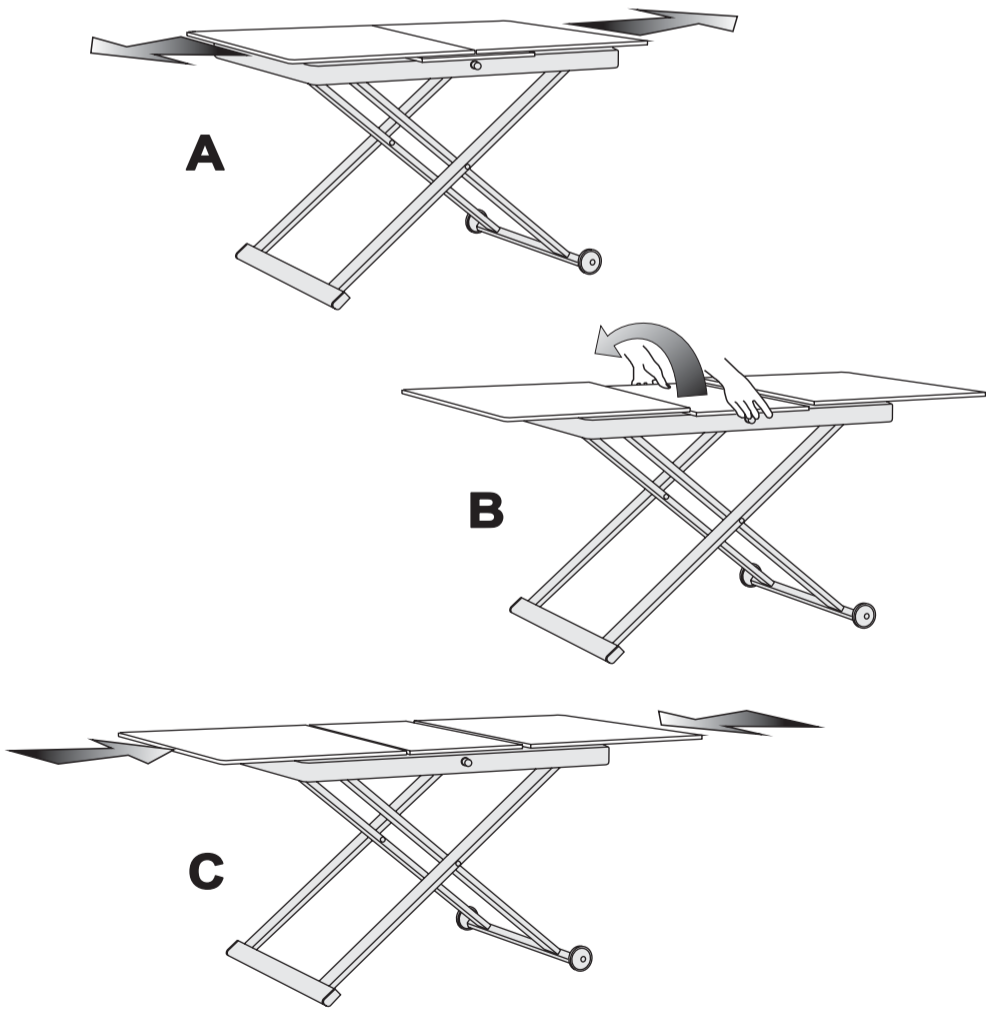

## Close

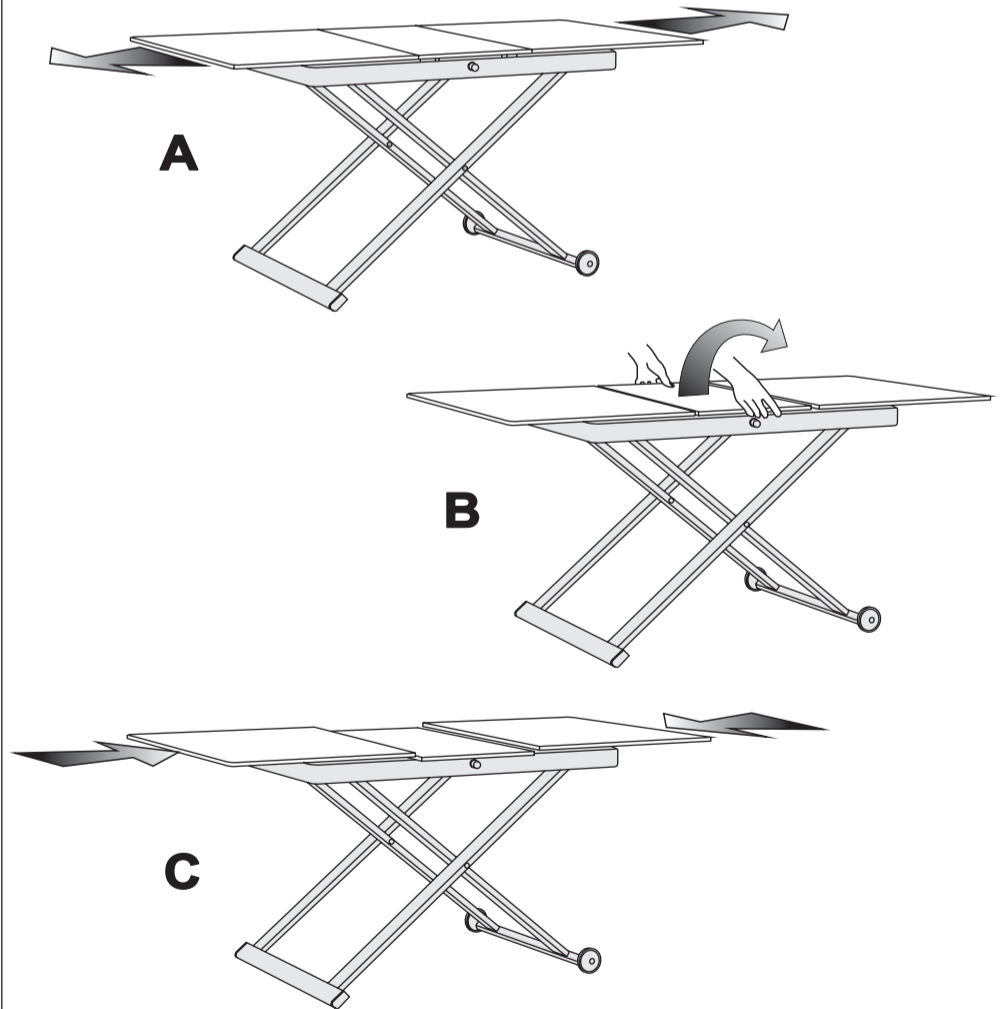

### Attenzione-Attention-Vorsicht-Attention-Atención

- I Verificare l'allineamento tra i piani e se necessario eseguire ulteriori regolazioni come da istruzioni sul retro.
- GB Please check the lining up between the individual parts of the table top and adjust them, if necessary, following the instruction on the back.
- D Richten Sie die Platten auf gleiche Höhe. Falls erforderlich bitte die notwendigen Anpassungen, wie laut Gebrauchsanweisungen auf der Rückseite, vornehmen.
- F Veuillez vérifier l'alignement entre les plateaux et, si nécessaire, le régler selon les instructions au verso.
- E Verificar el alineamiento entre los planos y si necesario ejecutar regulaciones ulteriores (véase las instrucciones al dorso).