



# Technical Data

# FOLDING SHOWER SEAT WITH PADDED CUSHION

# B-517 B-518

Specify Model Required:  Model B-517 right-hand seat  
 Model B-518 left-hand seat (shown)

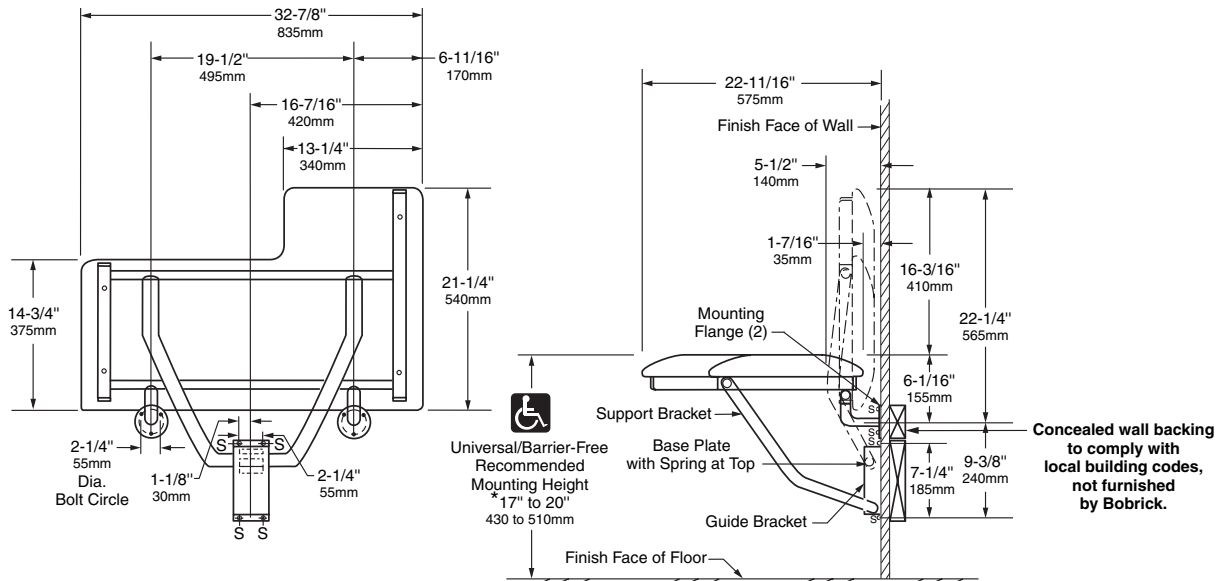

\*Consult local building codes

### MATERIALS:

**Seat** — 2" (51mm) thick overall with 1-1/2" (38mm) thick, closed-cell polyurethane foam padding mounted on 1/2" (13mm) thick plywood. Covered in white naugahyde (water-resistant, reinforced vinyl fabric).

**Frame** — 18-8 S, type-304 stainless steel with satin finish. 16-gauge (1.6mm), 1-1/4" (32mm) square members and 18-gauge (1.2mm), 1" (25mm) diameter tubing.

**Mounting Flanges (2)** — 18-8 S, type-304, 3/16" (5mm) thick stainless steel with satin finish. 3" (76mm) diameter with three mounting screw holes.

**Baseplate** — 18-8 S, type-304, heavy-gauge stainless steel.

**Spring** — 17-7, type-301, 24-gauge (0.6mm) stainless steel. Spot-welded to baseplate.

**Guide Bracket** — 18-8 S, type-304, 16-gauge (1.6mm) stainless steel with satin finish.

continued . . .

**OPERATION:**

Shower seat can be folded up against the wall when not in use. The spring at the top of baseplate locks seat into this upright position until released by pulling the top of seat away from wall. Support system with guide bracket allows varying mounting heights and leaves floor clear for easier cleaning. Bobrick shower seats when properly installed, have sufficient strength to support 400-lbs., (181-kg) complying with barrier-free accessibility guidelines (including ADAAG in the U.S.A.) for structural strength.

**INSTALLATION:**

Secure unit to wall at points indicated by an S, with the two mounting flanges located at top and the baseplate and guide bracket below. The bottom of support bracket must be positioned between the baseplate and guide bracket before they are secured to wall. Mounting height of shower seat must comply with local building codes.

For stud walls, provide concealed backing to comply with local building codes and secure with #14 x 2-1/2" (6.3 x 65mm) stainless steel sheet-metal screws furnished by manufacturer.

For prefabricated shower stalls, provided adequate backing by the shower stall manufacturer. Secure with #14 x 2-1/2" (6.3 x 65mm) stainless steel mounting screws furnished by manufacturer.

For masonry walls, provide fiber plugs or expansion shields for use with furnished screws, or provide 1/4" (6mm) toggle bolts or expansion bolts.

**Caution: These shower seats are no stronger than the anchors and walls to which they are attached and, therefore, must be firmly secured in order to support the loads for which they are intended. Consult and comply with local building codes.**

**SPECIFICATION:**

Folding shower seat shall have a frame constructed of type-304, satin-finish stainless steel that consists of 16-gauge (1.6mm), 1-1/4" (32mm) square tubing and 18-gauge (1.2mm), 1" (25mm) diameter seamless tubing. Seat cushion shall be 2" (51mm) thick consisting of 1-1/2" (38mm) closed cell polyurethane foam padding mounted on 1/2" (13mm) thick plywood and covered in white naugahyde (water-resistant reinforced vinyl fabric). Shower seat shall be equipped with two 3" (76mm) diameter mounting flanges constructed of type-304, 3/16" (5mm) thick, satin-finish stainless steel; a guide bracket constructed of type-304, 16-gauge (1.6mm), satin-finish stainless steel; and a spring constructed of type-301, 24-gauge (0.6mm) stainless steel that is spot-welded to a baseplate of type-304, heavy-gauge stainless steel. Shower seat shall be able to lock in upright position when not in use. Shower seat shall comply with barrier-free accessibility guidelines (including ADAAG in the U.S.A.) for structural strength. Manufacturer's service and parts manual shall be provided to the building owner/manager upon request.

**Folding Shower Seat shall be Model \_\_\_\_\_ (insert model number) of Bobrick Washroom Equipment, Inc., Clifton Park, New York; Jackson, Tennessee; Los Angeles, California; Bobrick Washroom Equipment Company, Scarborough, Ontario; Bobrick Washroom Equipment Pty. Ltd., Australia; and Bobrick Washroom Equipment Limited, United Kingdom.**