

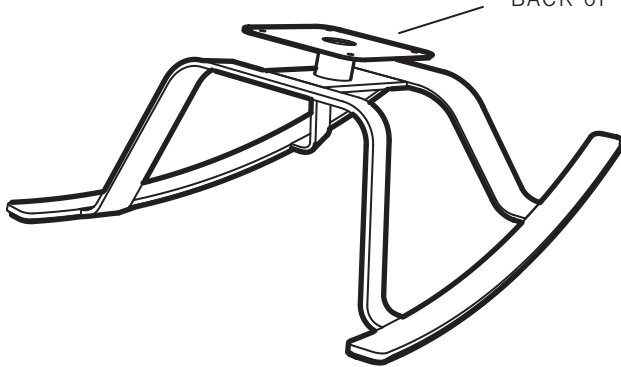

1

This is the BACK of the metal plate and should be oriented towards the BACK of the wood seat shell.



2

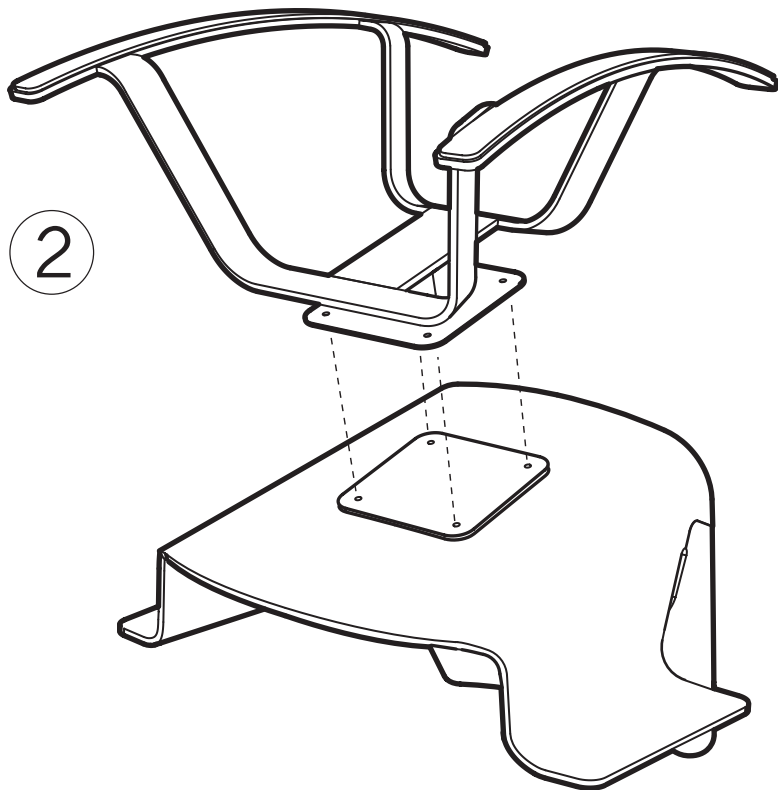

Grab a friend to help support seat shell during assembly.

- 1 Place the wood seat shell upside down on a carpet or protective mat.
- 2 Lift the base into position so that the holes in the mounting plate align with the holes in the bottom of the seat shell. Place a washer on each screw then insert a screw through each of the four holes and use the hex key to tighten each screw as tightly as possible. The washer should be located between the screw head and the metal mounting plate. Rock on!

REV 0 2006.09.15

## HARDWARE INVENTORY

