

# AVS-425

## ASSEMBLY INSTRUCTIONS

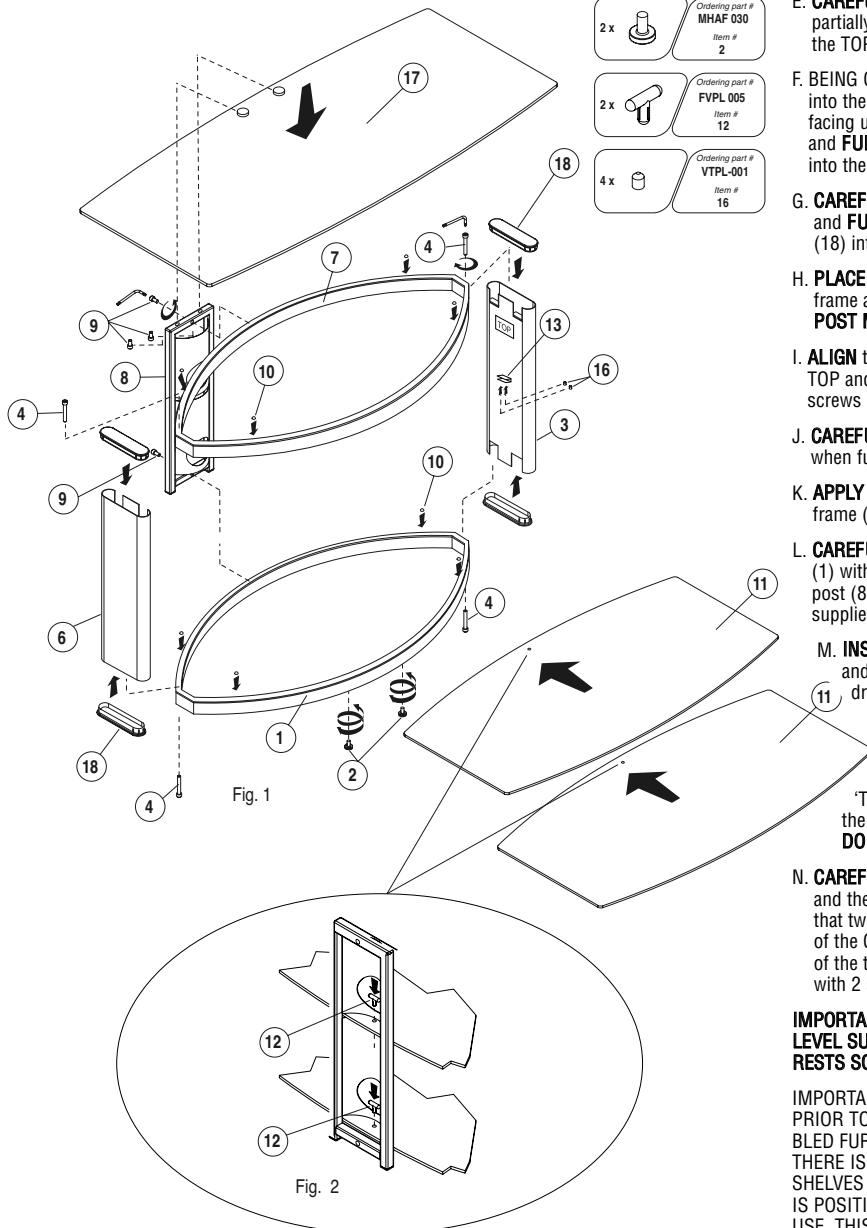

**Bell'O International Corp.**  
 711 Ginesi Drive  
 Morganville, NJ 07751-1235  
 Customer Service: (888) 235-7646  
 E-mail: support@bello.com  
 Web: www.bello.com



**NOTE: TWO PEOPLE ARE RECOMMENDED TO ASSEMBLE THIS UNIT. THIS FURNITURE SHOULD BE ASSEMBLED ON A SOFT SURFACE.**

- 1 x Ordering part # CHFE 007  
Sheet nr. ALLEN WRENCH
- 1 x Ordering part # CHPL 001  
Sheet nr. PHILLIPS DRIVER
- 4 x Ordering part # MHS 052  
Item # 9
- 4 x Ordering part # MHS 174  
Item # 4
- 8 x Ordering part # MHGP 021  
Item # 10
- 2 x Ordering part # MHAF 030  
Item # 2
- 2 x Ordering part # FVPL 005  
Item # 12
- 4 x Ordering part # VTPL-001  
Item # 16

- A. REMOVE** the two oval metal frames from the carton and place the TOP frame (7), identified by the "TOP" sticker, to the side. **SELECT** the BOTTOM frame (1), identified by the two threaded metal inserts on the bottom center of the frame, and **SCREW** the leveling feet (2) into the threaded insert.
- B. PLACE** the BOTTOM frame (1) with the leveling feet (2) on the floor facing towards the front. **BEING CAREFUL NOT TO SCRATCH** the BOTTOM frame, **POSITION** the RIGHT side leg (3) and LEFT side leg (6) over the BOTTOM frame as shown in Fig.1. with the "TOP" sticker on the legs pointing upwards and the shelf support clips facing towards the opposite leg.
- C. BEING CAREFUL NOT TO SCRATCH** the TOP frame, **PLACE** the TOP frame (7) into the leg cutouts at the top of both legs, so that the Bell'O logo is facing forward near the right leg (3).
- D. SECURE** the TOP frame (7) to both legs, using two of the long screws (4) and the supplied Allen wrench. **NOTE: DO NOT FULLY TIGHTEN THE SCREW AT THIS POINT.**
- E. CAREFULLY LIFT** TOP frame and both legs off of the BOTTOM frame, and **TURN** the partially assembled table over and **GENTLY** place it on the floor, so that it is resting on the TOP frame and the legs are facing upwards.
- F. BEING CAREFUL NOT TO SCRATCH** the BOTTOM frame, **PLACE** the BOTTOM frame (1) into the leg cutouts at the exposed ends of both legs, so that the leveling feet (2) are facing upwards. **SECURE** the BOTTOM frame (1) to the legs with two long screws (4) and **FULLY TIGHTEN** using the supplied Allen wrench. **INSERT** the plastic caps (18) into the end of each leg.
- G. CAREFULLY turn** the table over so that it is resting on the BOTTOM frame. **GO BACK** and **FULLY TIGHTEN** screws that secure the legs to the frame. **INSERT** the plastic caps (18) into the end of each leg.
- H. PLACE** the CMS® (Cable Management System®) post (8) upright against the rear of the frame as shown in Fig.1. **NOTE: THE TWO HOLES IN THE TOP FRAME OF THE CMS® POST MUST BE FACING UPWARDS.**
- I. ALIGN** the top and bottom holes of the CMS® post with the holes located on the rear of TOP and BOTTOM frames (1) and (7). **SECURE** the CMS® to the frames using two short screws (9) and the Allen wrench.
- J. CAREFULLY MOVE** and **POSITION** the furniture to the location it will occupy in the room when fully assembled and in use.
- K. APPLY** the four rubber glass pads (10) to the upper sides of the TOP (7) and BOTTOM frame (1) as shown in Fig. 1.
- L. CAREFULLY SLIDE** one of the two smaller glass shelves (11) onto the BOTTOM frame (1) with the glass shelf locking pin hole inserted through the bottom slot of the CMS® post (8). **LOCK** the glass shelf in place, from the rear of the CMS® post, using the supplied 'T'-shaped plastic shelf locking pin (12) as shown in Fig.2.
- M. INSERT** the supplied set screws (16) part of the way into the glass shelf clips (13) and partially tighten them using the supplied Phillips driver (14) or your own screw driver, leaving enough room to slide the shelf into the clip. **CAREFULLY SLIDE** the second of the two smaller glass shelves (11) through the shelf support clips (13) located on the center of the two side legs (3) and (6), so that the shelf locking pin hole is inserted through the slot of the CMS® post (8). **LOCK** the glass shelf in place, from the rear of the CMS® post, using the supplied 'T'-shaped plastic shelf locking pin (12) as shown in Fig.2. **SECURE** tightly into the glass shelf clips (13) using the supplied set screws (16) and Phillips driver (14). **DO NOT OVERTIGHTEN.**
- N. CAREFULLY position** and place the top glass shelf (17), the largest of the three shelves, and the one with the two SILVER DISCS, onto the top of the assembled furniture so that two silver discs are facing towards the rear and **ALIGNED** with the holes in the TOP of the CMS® post (8). Working from the REAR of the furniture, and from the underside of the top frame of the CMS® post, **SECURE** the TOP glass shelf (17) to the CMS® post with 2 smaller screws (9) using the supplied Allen wrench.

**IMPORTANT NOTE: WHEN IN USE, THIS FURNITURE MUST BE PLACED ON A FLAT AND LEVEL SURFACE. ADJUST THE TWO FRONT LEVELING FEET UNTIL THE FURNITURE RESTS SQUARELY ON THE FLOOR.**

**IMPORTANT: REMOVE ALL GLASS, TV AND OTHER EQUIPMENT FROM THE FURNITURE PRIOR TO MOVING THE ASSEMBLED UNIT. DO NOT ATTEMPT TO MOVE THE ASSEMBLED FURNITURE AFTER THE GLASS SHELVES HAVE BEEN INSTALLED, AND/OR WHEN THERE IS EQUIPMENT LOCATED ON THE FURNITURE AS THIS MAY CAUSE THE SHELVES TO BECOME INSECURE AND FALL. MAKE SURE THAT THE FRONT OF THE TV IS POSITIONED A FEW INCHES BACK FROM THE FRONT OF THE TOP GLASS. WHEN IN USE, THIS FURNITURE MUST BE PLACED ON A FLAT AND LEVEL SURFACE.**

ALWAYS PLACE THE HEAVIEST EQUIPMENT ON THE BOTTOM SHELF.