

AVS-4212T

ASSEMBLY INSTRUCTIONS



Bell'O International Corp.

711 Ginesi Drive
Morganville, NJ 07751-1235
Customer Service: (888) 235-7646
E-mail: support@bello.com
Web: www.bello.com

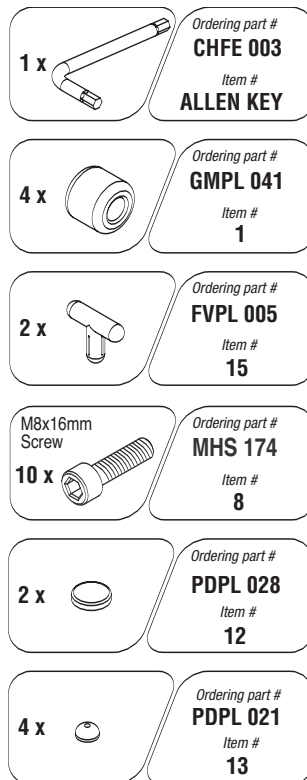

Note: Two people are recommended to assemble this furniture.

A. PLACE one of the four tube-shaped rubber glass pads (1) over one end of each of the four glass shelf support crossbars (2) as shown in Fig.1, leaving approximately 2" of the crossbar support ends exposed .

B. STAND the rear frame (3) upright with the glass shelf slots of the CMS® (Cable Management System) post (4) facing forward, and the the two frame supports (5) positioned at the top of the frame and facing the center of the unit as shown in Fig.1.

C. INSERT the end with the rubber glass pads on each of the four glass shelf support crossbars (2) into the pre-drilled holes (6) located on the left and right front uprights of the rear frame front (3) as shown in Fig. 1.

D. SLIDE each of the two rectangular connecting crossbars (7) onto the two frame supports (5) with the predrilled holes facing downwards, and secure each from the underside with two of the eight larger screws (8) using the supplied Allen wrench.

E. STAND the front frame (9) upright with the two front frame supports (10) facing the center of the unit as shown in Fig.1. SLIDE the front frame supports (10) into the two rectangular connecting crossbars (7) and INSERT the four glass support crossbars (2) into the predrilled holes on middle and bottom glass support crossbars (11) located on the inside of the front frame (9). SECURE the front frame to the rectangular connecting crossbars (7) from the underside, with the four remaining larger screws (8) as shown in Fig.1. TIGHTEN all 8 screws securely using the supplied Allen wrench.

F. APPLY the two large flat rubber glass pads (12) to the top corners of the front frame structure (9). APPLY the four small rubber glass pads (13) onto the middle and bottom glass support crossbars (11) as shown in Fig.1.

G. POSITION the furniture at the location it will occupy in the room when fully assembled and in use.

H. From the front of the unit, CAREFULLY SLIDE one of the two supplied smaller glass shelves (14) onto the bottom glass shelf support crossbars (2 and 11) so that the smooth side is facing upwards, and the hole in the glass shelf is facing towards the rear and inserted through the slot in the CMS® post (4). SECURE the glass shelf behind the CMS® post using one of the two supplied plastic 'T' pins (15) as shown in Fig.2. REPEAT the same procedure for the middle glass shelf (14).

I. CAREFULLY position and place the top glass shelf (16) onto frame as shown in Fig. 1. with the smooth surface facing upwards and the two silver discs placed into the holes on the top of the CMS® post (4). SECURE the top glass, from below the rear of the CMS® post using two screws (8).

IMPORTANT: REMOVE ALL GLASS, TV AND OTHER EQUIPMENT FROM THE FURNITURE PRIOR TO MOVING THE ASSEMBLED UNIT. DO NOT ATTEMPT TO MOVE THE ASSEMBLED FURNITURE AFTER THE GLASS SHELVES HAVE BEEN INSTALLED, AND/OR WHEN THERE IS EQUIPMENT LOCATED ON THE FURNITURE AS THIS MAY CAUSE THE SHELVES TO BECOME UNSECURE AND FALL. MAKE SURE THAT THE FRONT OF THE TV IS POSITIONED A FEW INCHES BACK FROM THE FRONT OF THE TOP GLASS. WHEN IN USE, THIS FURNITURE MUST BE PLACED ON A FLAT AND LEVEL SURFACE.

ALWAYS PLACE THE HEAVIEST EQUIPMENT ON THE BOTTOM SHELF.

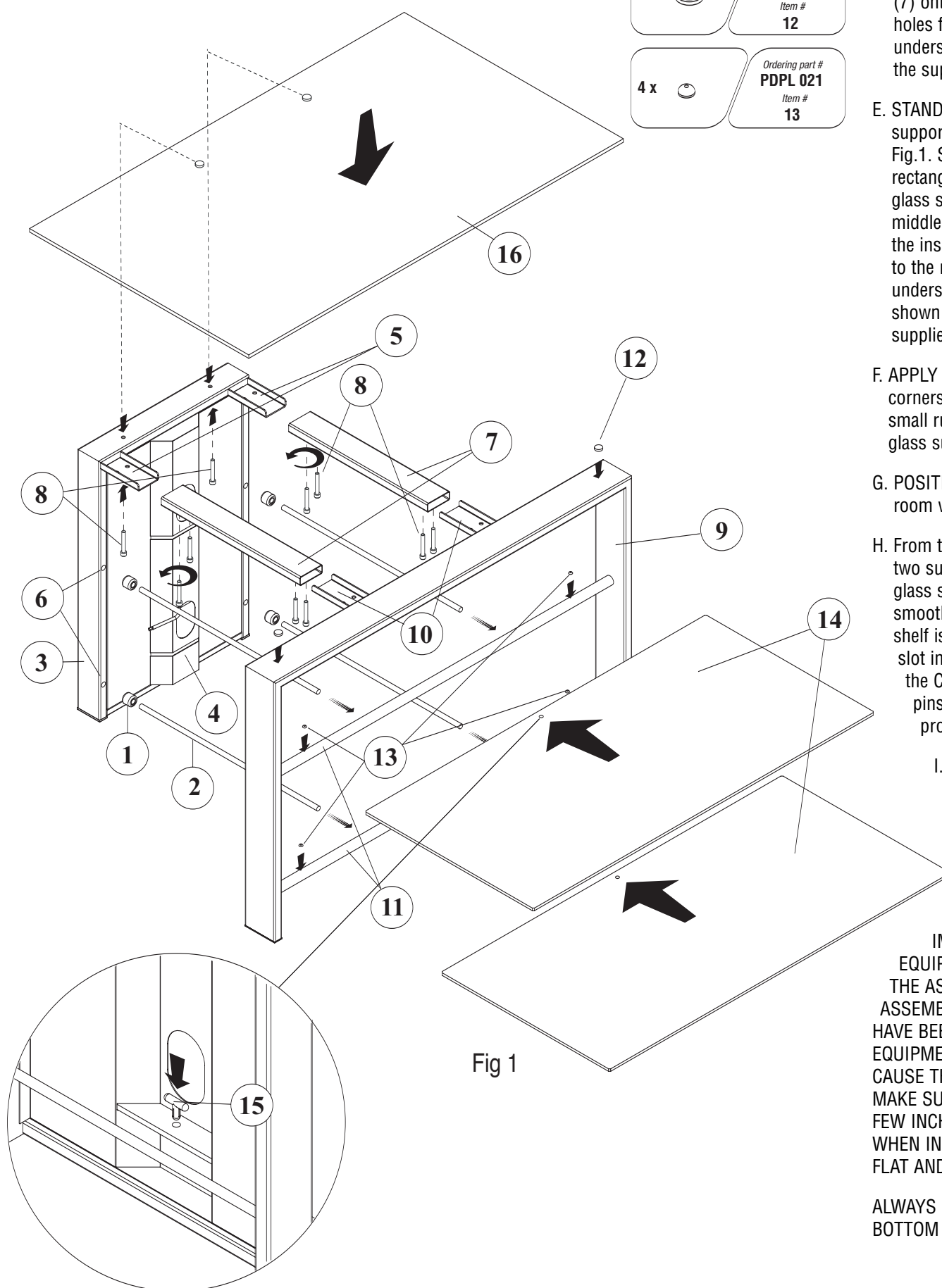

Fig 1

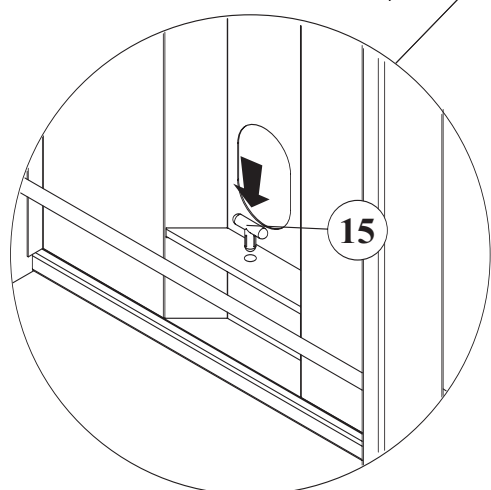

Fig 2