



Play Smarter System™ Shop & Learn Market

Ages 3+

WARNING:
CHOKING HAZARD—Small parts.
Not for children under 3 years.

Item no.: 600715

ADULT BATTERY INSTALLATION REQUIRED

INTRODUCTION

Your child can get an early start in learning with the Little Tikes™ Play Smarter™ Shop & Learn Market Playset! This groovy grocery store has both shop and quiz modes that teach your child basic colors, numbers, foods and food groups! It also features the Play Smarter™ scoring system that helps you keep track of your child's progress so you can see how well your little tike is developing!

CONTENTS

- 1 Play Smarter™ Shop & Learn Market Playset including:
 - 1 Market Base
 - 2 Supports
 - 1 Scale Assembly
 - 1 Top Shelf
 - 1 Top Shelf Backboard
- 10 Food items
- 1 Plastic ATM Card
- 3 Plastic "Dollar Bills"
- 6 Plastic Coins



'Let's care for the environment!'
The wheelee bin symbol indicates that the product must not be disposed of with other household waste. Please use designated collection points or recycling facilities when disposing of the item.

Please keep this manual as it contains important information.



0507-0-E/INT

TM & © The Little Tikes Company,
an MGA Entertainment company.
LITTLE TIKES™ and all related logos, names,
characters, distinctive likenesses and slogans, as well
as the packaging and images appearing thereon, are
the exclusive property of The Little Tikes Company.
Little Tikes Consumer Services
2180 Barlow Road
Hudson, Ohio 44236 USA
(800) 321-0183
Printed in China

Visit us at www.littletikes.com

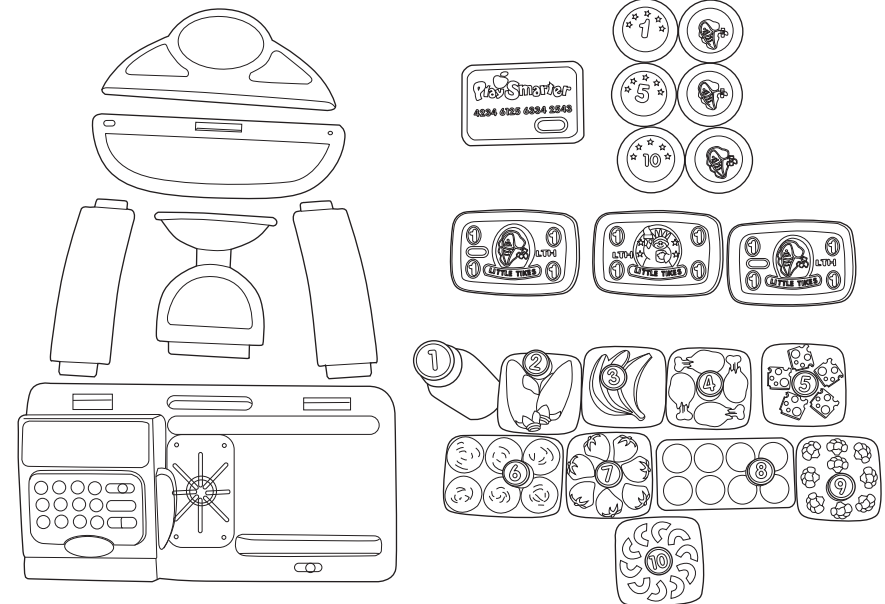

Illustrations may vary from actual contents.

BEFORE YOU BEGIN

Before shopping for success, ask an adult to help install the batteries:

1. Using a Phillips screwdriver (not included) remove the screw and battery compartment cover from the back of the Cash Register on the Market Base.
2. Install three (3) AA alkaline batteries (not included) making sure the (+) & (-) ends face the proper direction as indicated inside the battery compartment.
3. Replace the compartment cover and tighten the screw.

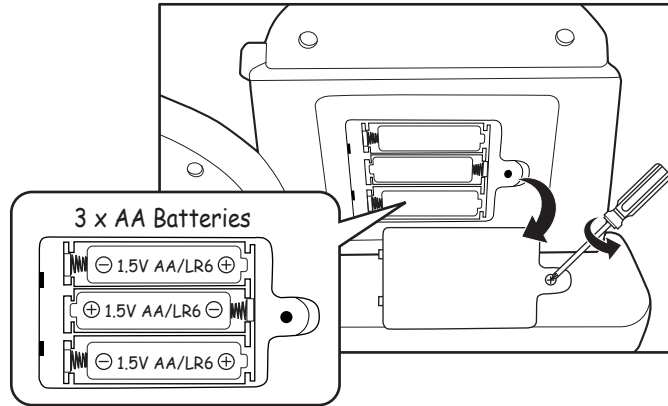

QUICK START

Assembly:

Always have an adult help with assembly.

1. Set the Market Base on a smooth, level surface.
2. Attach the Scale assembly to the back of the Base as shown, it will snap into place. (Fig. 1)
3. Attach the Supports on either side of the Scale Assembly as shown, they will snap into place. (Fig. 2 and Fig. 3)
4. Attach the Top Shelf to the Supports as shown, it will snap into place. (Fig. 4)
5. Attach the Backboard to the Top Shelf, it will snap into place. (Fig. 5)
6. Your completed Shop & Learn Market Playset should look like Fig. 6.

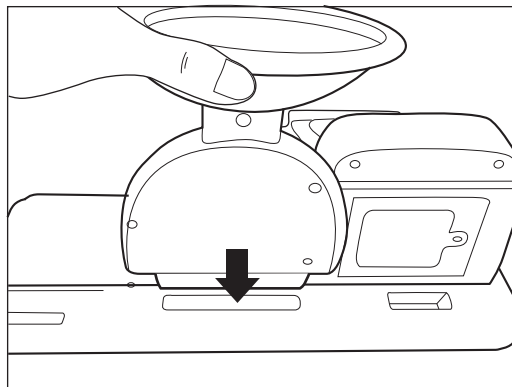

Spring scale assembly

Fig. 1

FCC Compliance

NOTE: This equipment has been tested and found to comply with the limits for Class B digital device, pursuant to Part 15 of FCC Rules. These limits are designed to provide reasonable protection against harmful interference in a residential installation. This equipment generates, uses and can radiate radio frequency energy and, if not installed and used in accordance with the instructions, may cause harmful interference to radio communications. However, there is no guarantee that interference will not occur in a particular installation. If this equipment does cause harmful interference to radio or television reception, which can be determined by turning the equipment off and on, the user is encouraged to try to correct the interference by one or more of the following measures:

- Reorient or relocate the receiving antenna.
- Increase the separation between the equipment and receiver.
- Connect the equipment into an outlet on a circuit different from that to which the receiver is connected.
- Consult the dealer or an experienced radio/TV technician for help.

This device complies with Part 15 of the FCC Rules. Operation is subject to the following two conditions: (1) This device may not cause harmful interference, and (2) this device must accept any interference received, including interference that may cause undesired operation.

Caution: Modifications not authorized by the manufacturer may void users authority to operate this device.

SAFE BATTERY USAGE

- Use alkaline batteries for best performance and longer life.
- Use only the type battery recommended for the unit.
- Batteries should be replaced only by an adult.
- Insert batteries with the correct polarity (+ and -).
- Do not mix different types of batteries or old and new batteries.
- Do not short-circuit batteries.
- When not used for an extended time, remove batteries to prevent possible leakage and damage to the unit.
- Do not mix rechargeable and non-rechargeable batteries.
- Rechargeable batteries are to be removed from the toy before charging.
- Rechargeable batteries are to be recharged only under adult supervision.
- Do not recharge non-rechargeable batteries.
- Exhausted batteries are to be removed from the toy.
- Do not dispose of batteries in fire as they may leak or explode.

DISPOSAL OF BATTERIES: Do not treat old batteries as household waste. Take them to a designated recycling facility.

NOTE: The voltage of a fully-charged, rechargeable battery is often lower than that of a fresh alkaline battery. Therefore, it is recommended that alkaline batteries be used instead of rechargeable batteries for best performance and for longest play time.

QUICK START (con't)

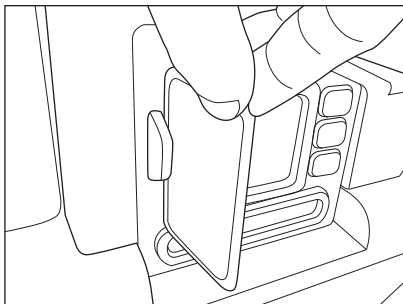

Fig. 8

- Put your knowledge to the test by arranging the food items on the Storage Shelf. Organize them by color, number, food group or whatever you choose!
- Press the Shop button at any time during a Quiz to go back into Free Play mode.

QUIZ MODE

With three different categories and three difficulty levels, your Little Tikes™ Play Smarter™ Shop & Learn Market Playset has nine different quizzes to test your child's knowledge. In addition, each quiz asks questions in a random order so no two quizzes are exactly alike!

The Table below shows the nine different quizzes and examples of questions that are asked:

	LEVEL ONE (four questions)	LEVEL TWO (six questions)	LEVEL THREE (eight questions)
COLORS	"Please scan the red food".	Please scan the red food with the number seven".	Please scan the red food with a number greater than 3 but less than 8".
NUMBERS	"Please scan the food with the number five".	Please scan five items".	Please scan the food with a number greater than 4 but less than 6".
FOODS	"Please scan the milk".	"Please scan a food that is calcium rich".	"Please scan a food that is calcium rich, and has a number greater than 1 but smaller than 4".

To Play:

1. Set the 3-Way Mode switch to the desired category.
2. Set the Difficulty Level switch on the Cash Register to the desired level.
3. Press the Quiz button on the Cash Register. The quiz will begin!
4. When the question is asked, take the correct item and move it over the scanner.
5. The unit will tell you if the correct item was scanned and tally up your score.
6. After all of the questions are answered, the unit will tell you the score.

PLAY SMARTER™ FEATURE

Parents can check their child's progress by pressing the Play Smarter™ button after a quiz. A series of 5 lights will light up to show the percentage of questions that the child got right.

The percentages are:

- 5 Lights = 100% (The Corner Store will also play a Fanfare!)
- 4 Lights = 75% to 99%
- 3 Lights = 50% to 74%
- 2 Lights = 25% to 49%
- 1 Light = less than 25%

QUICK START (con't)

Left & Right support assembly

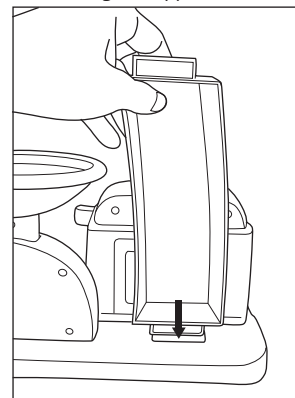

Fig. 2

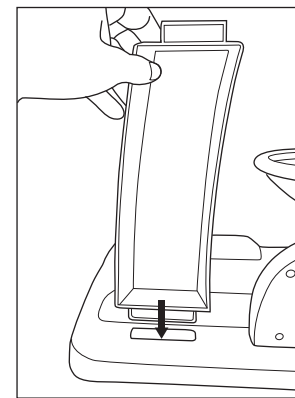

Fig. 3

Food storage shelf assembly

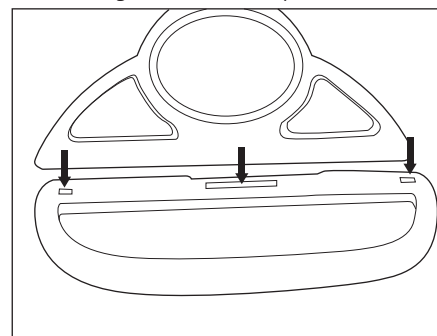

Fig. 4

Attach Food storage shelf to support tops.

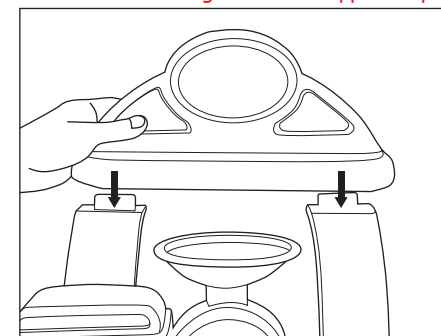

Fig. 5

Completed

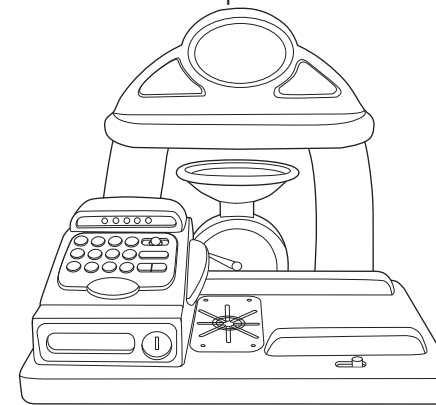

Fig. 6

NOTE: Once the Shop & Learn Market Playset is assembled, it cannot be disassembled.

QUICK START (con't)

FEATURES AND BUTTONS

The Shop & Learn Market is made up of the following features:

- a. Food Storage Shelf
- b. Scale Assembly
- c. Three-Way Mode Switch:
 - Colors
 - Numbers
 - Foods
- d. Flatbed Scanner
- e. Cash Register Keypad
- f. Cash Register Swipe
- g. Cash Drawer
- h. Role Play ATM
- i. On/Off Switch

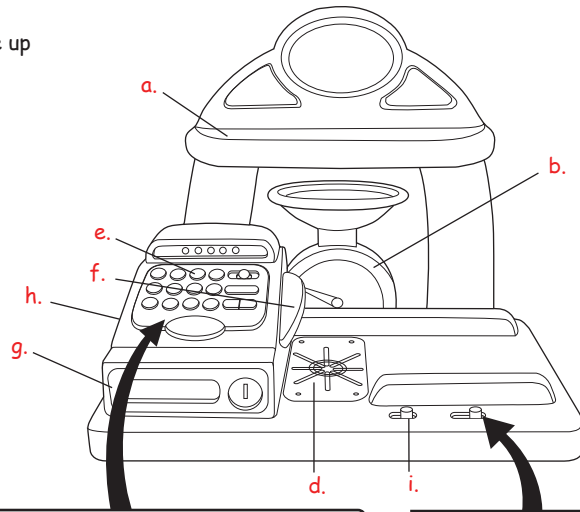

Additionally, the Cash Register Keypad is made up of the following buttons:

- n. 1 - 10 Number buttons
- o. Music Button
- p. Food Groups button
- q. Difficulty Level Switch
- r. Play Smarter™ button
- s. Quiz button
- t. Shop button
- u. Open Cash Drawer button

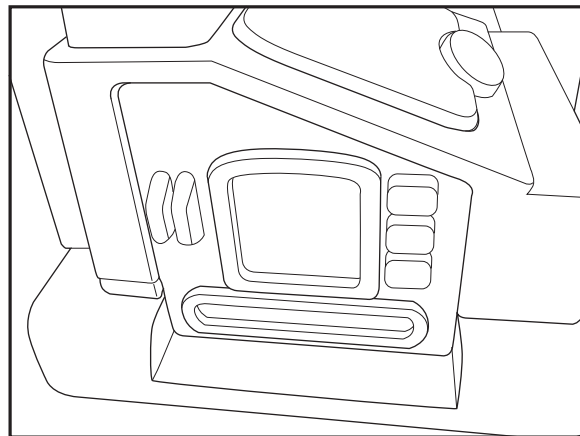
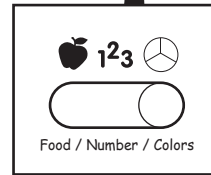
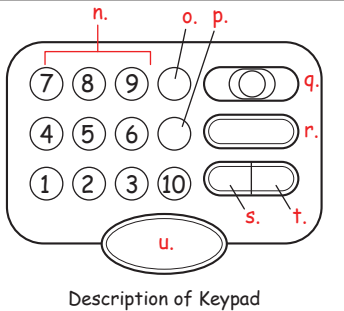

h. Role play ATM

QUICK START (con't)

FREE PLAY MODE

This mode opens up all of the features of the Shop & Learn Market to encourage active play. Your child will have hours of fun with the following activities:

Food Checkout:

Just like a real grocery store! Slide the food items over the Flatbed Scanner. As your child scans the items, the Corner Store will identify the item by number, color, food or food group.

To Play:

1. Set the **3-Way Mode** switch to one of three categories - colors, numbers or foods.
2. Pick up the first food item and move it across the scanner, just like a real checkout clerk!
3. If the **3-Way Mode** switch is set to **COLORS**, the unit will tell you the color of the food item. Example: If you scan the Bananas, the unit will say "yellow".
4. If the **3-Way Mode** switch is set to **Numbers**, the unit will tell you the number on the food item. Example: If you scan the Chicken, the unit will say "4".
5. If the **3-Way Mode** switch is set to **FOODS**, the unit will tell you the name of the food item you are scanning. Example: If you scan the Milk, the unit will say "milk".

Other Free Play Notes:

- Before scanning a food item, press the Food Groups button on the Cash Register keypad. The unit will tell you something special about the food item. Example: If you scan the Milk, the unit will say "Milk is calcium rich". If you scan the Bananas, the unit will say "Bananas are a fruit".
- The Number keys on the Keypad say the number on the pressed key. Press the Music button to hear a song!
- When you are finished scanning food items, "pay" for your groceries in one of two ways:
 - Slide the ATM card through the Cash Register Swipe by the keypad. (Fig. 7)
 - Pay with "cash" by pressing the Open button on the keypad and placing the pretend money in the drawer.

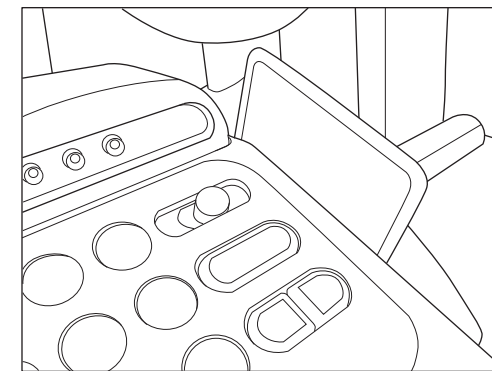

Fig. 7

- Slide your ATM Card through the ATM on the side of the Market. Press the Open button to "withdraw" your money, or place money in the drawer as a "deposit". (Fig. 8)