

American Standard

JASMINE
AMARILIS

**THREE HANDLE
BATH/SHOWER SETS**

Thank you for selecting American-Standard...the benchmark of fine quality for over 100 years.

To ensure that your installation proceeds smoothly—please read these instructions carefully before you begin.

**Installation
Instructions
3630 SERIES**

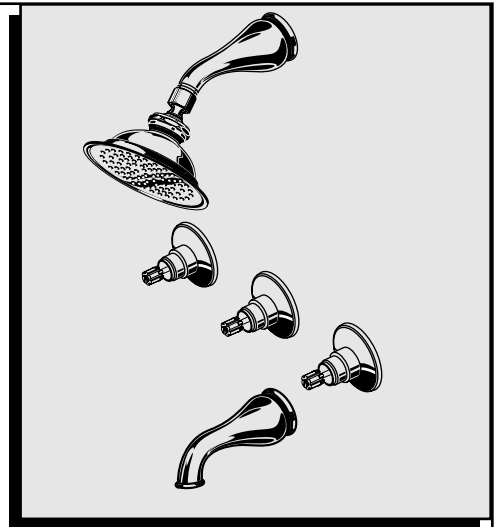

Certified to comply with ASME A112.18.1M
U.S. Patent No. 5,819,789
M968715A

ROUGHING-IN DIMENSIONS

NOTE: NO CONCEALED PIPING FURNISHED

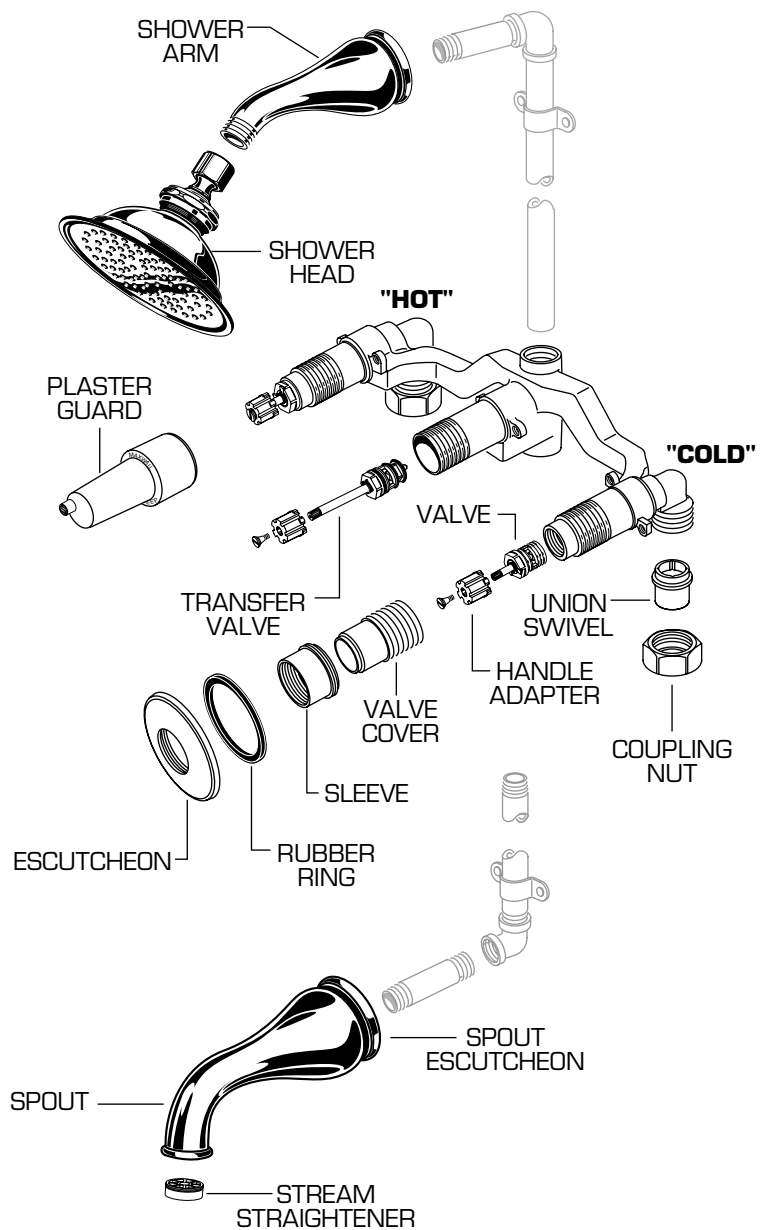
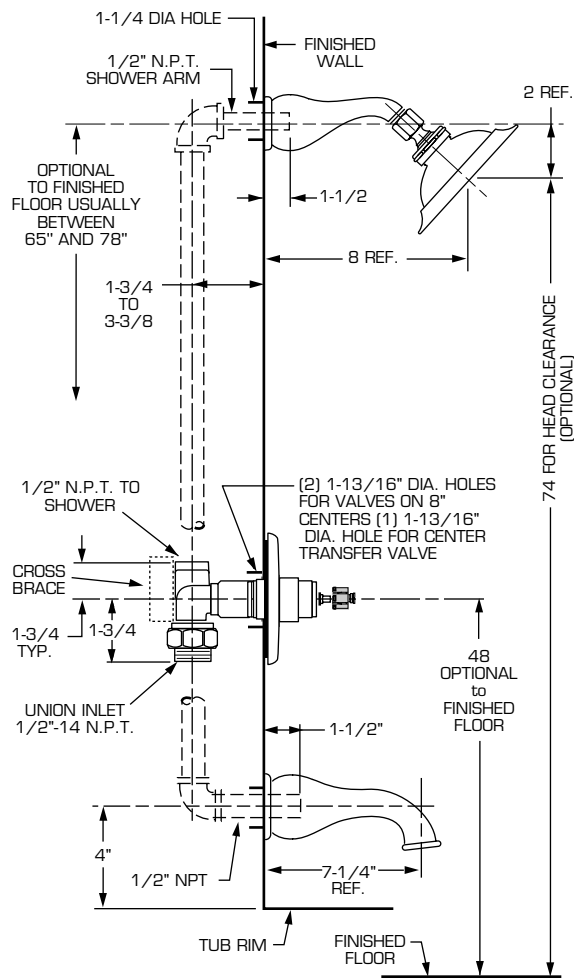

1

CAUTION

Turn off hot and cold water supplies before beginning.

ROUGHING-IN FITTING

- Prepare water supplies per "Roughing-in Dimensions."
- Slip COUPLING NUT over supply pipe and screw UNION SWIVEL to pipe.
- For Sweat Connection: Slip COUPLING NUT over 5/8" O.D. supply tube and solder tube into UNION SWIVEL or female inlet of valve.
- Install VALVE at indicated height and depth. Notice that finished wall has to be between the MAX WALL and MIN. which is 1-5/8" below.
- Connect HOT water supply to left VALVE inlet and COLD water supply to right VALVE inlet. Tighten both COUPLING NUTS firmly.
- Secure VALVE BODY to cross brace of wall structure.

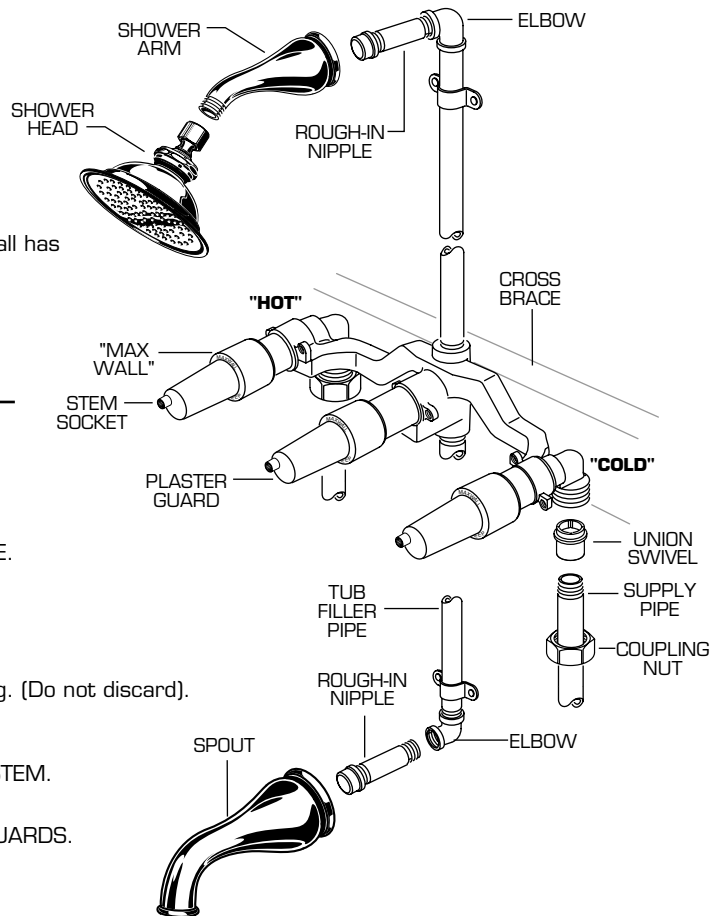

2

ROUGHING-IN SHOWER AND SPOUT

- Prepare SHOWER RISER, ELBOW, and roughing-in NIPPLE and connect to top outlet of VALVE BODY. Outlet is 1/2" female NPT.
- Prepare TUB FILLER PIPE, ELBOW and 1/2" N.P.T. SPOUT NIPPLE. Final length of SPOUT NIPPLE to be 1-1/2" from finished wall.
- Add cross braces to wall structure and secure piping.
- Cap roughing-in nipples, open supply lines and check for leaks.
- Remove PLASTER GUARDS by turning counter clockwise and pulling. (Do not discard).
- PLASTER GUARD has a STEM SOCKET to operate valves.
- Turn PLASTER GUARD over and push STEM SOCKET onto VALVE STEM. Open hot and cold valves and check for leaks.
- Close both valves, turn off water supplies, and replace PLASTER GUARDS.
- Finish wall construction.

3

FINISHING INSTALLATION

- Remove caps from roughing-in nipples.
- Remove PLASTER GUARD by turning counter-clockwise and pulling.
- If VALVE BODY is roughed in SHALLOW (more than 2-1/2") screw SLEEVE in ESCUTCHEON facing front of ESCUTCHEON.
- If VALVE BODY is roughed in DEEP (less than 2-1/2") screw SLEEVE in ESCUTCHEON facing back of ESCUTCHEON.
- Assemble RUBBER RING to ESCUTCHEON.
- Screw ESCUTCHEON and SLEEVE onto VALVE COVER against wall.
- Install SHOWER ARM, SHOWER ARM FLANGE and TUB SPOUT.

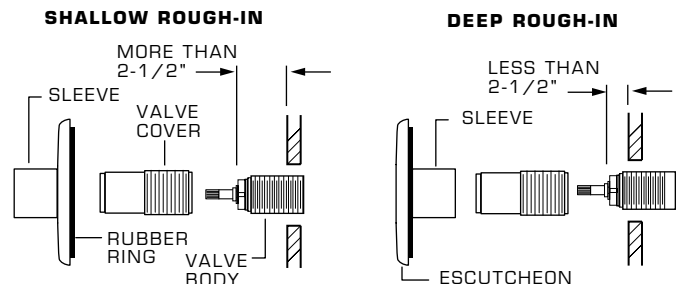

4

TEST INSTALLED FAUCET

- Turn HANDLES into "off" position.
- Turn on water supplies and check all connections for leaks.
- Operate both HANDLES to flush water lines thoroughly.
- Check SHOWER HEAD and connections for leaks.
- Turn handles into OFF position.

5

SERVICE

- To change direction of handle rotation, proceed as follows:
 - Turn valve to OFF position.
 - Pull out INDEX CAP and remove HANDLE SCREW.
 - Pull off HANDLE BASE and remove ADAPTER.
 - Remove SPRING CLIP.
 - Lift STOP WASHER, turn 90 and replace.
 - Replace SPRING CLIP.
 - Reinstall HANDLE. (See step 4).

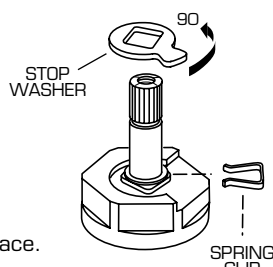

- If spout drips, operate handles several times from OFF to ON position. Do not force - handles turn only 90.



HOTLINE FOR HELP
 For toll-free information and answers to your questions, call:
 1 (800) 442-1902
 Weekdays 8:00 a.m. to 7:00 p.m. Eastern Time
 IN CANADA 1-800-387-0369 (TORONTO 1-905-306-1093)

Product names listed herein are trademarks of American Standard Inc.
 ©American Standard Inc. 2000

M968715A