

Assembly Diagram

Model No: V44Y76, V44Y76B, V44Y76CB

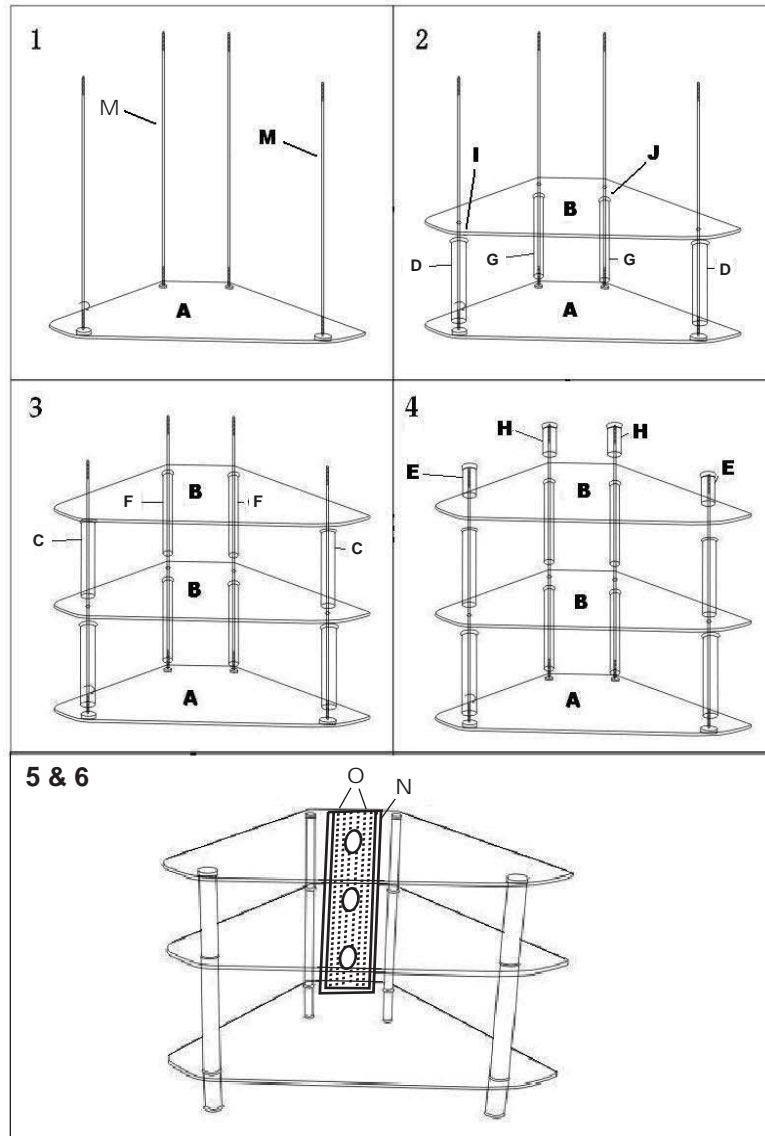

A		Top Glass	1
B		Middle/Bottom Glass	2
C		10" Cylinder	2
D		7" Cylinder	2
E		3" Cylinder	2
F		10" Cylinder	2
G		7" Cylinder	2
H		3" Cylinder	2
I		Large Rings	8
J		Small Rings	8
K		Large Cap (Attached to E)	2
L		Small Cap (Attached to H)	2
M		Rod	4
N		Cable Mgmt.	1
O		Rods (xs), Nuts	2
P		Wrench	1

**** Note: Some parts may be pre-assembled for shipping purposes and must be disassembled for assembly. Extra parts have also been included. Both black (B) and clear black (CB) models come with chrome AND black ring sets ("I" and "J").**



Additional Info

While assembling your stand, please note that the decorative rings require correct placement on the cylinders for the stand to fit together properly.

Each decorative ring has a flat side and a cupped side.

The flat side of the ring must always face toward the glass.

The cupped side of the ring must always face toward the cylinder and be seated completely against the cylinder.

For our most up to date instruction, to request missing, lost, or broken parts, or for any other Customer Service issues, please visit our website at www.walkerredison.com or call us at 877-207-5906.

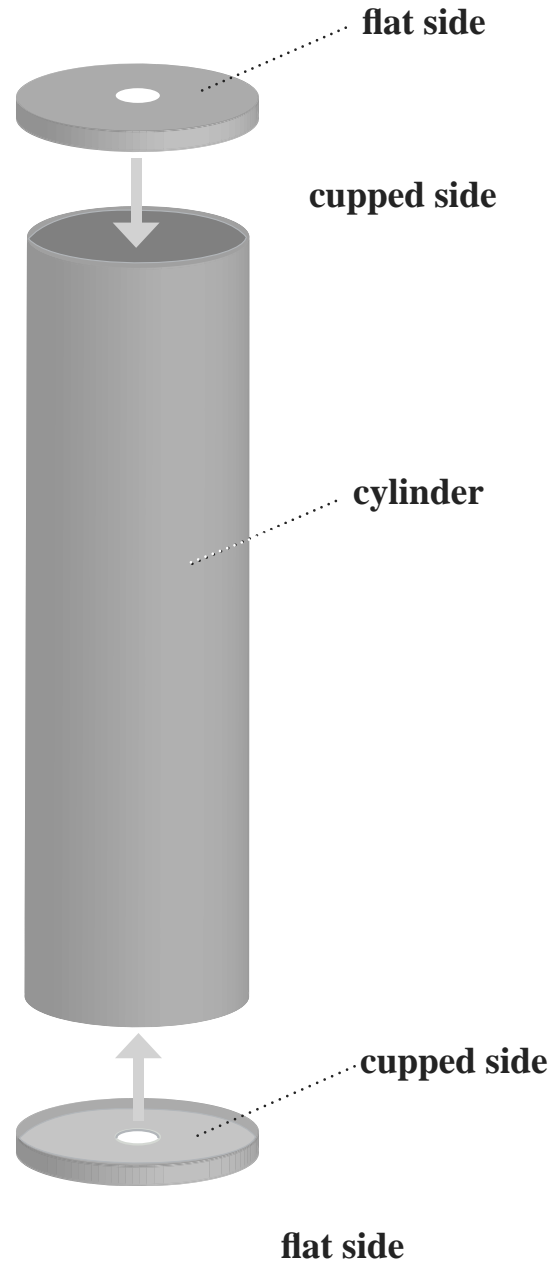

finished cylinder assembly

