

DP Plasma A/V Component Rack

Page 1 of 7

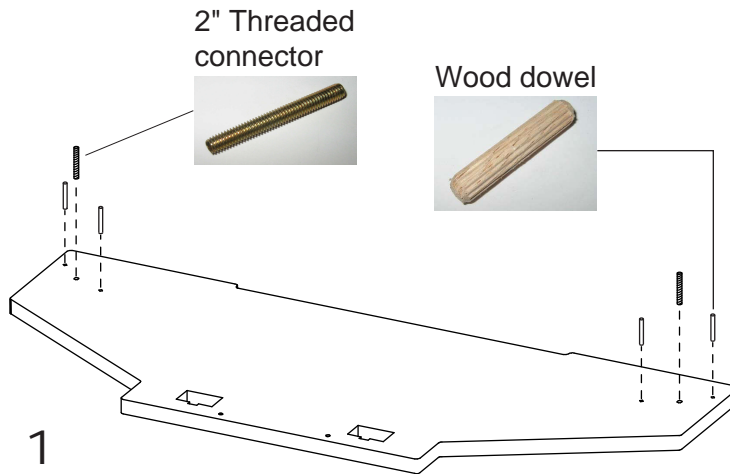

Lay the top shelf on a soft surface upside down. Then screw two threaded connectors into the threaded inserts and push in 4 wood dowels as shown.

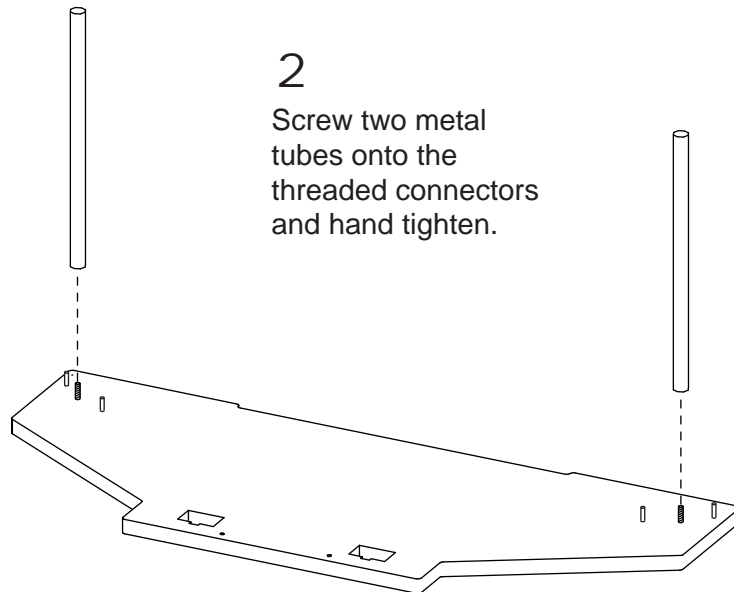

DP Plasma A/V Component Rack

Page 2 of 7

3

Slide the wood pillar over the metal tube and gently press the pillar in place over the wood dowels as shown here.

The pillar should have a sticker here that says "bottom"

Bottom

BE CERTAIN THAT THE PILLAR IS INSTALLED WITH THE SLOTS IN THIS POSITION DURING THIS STEP.

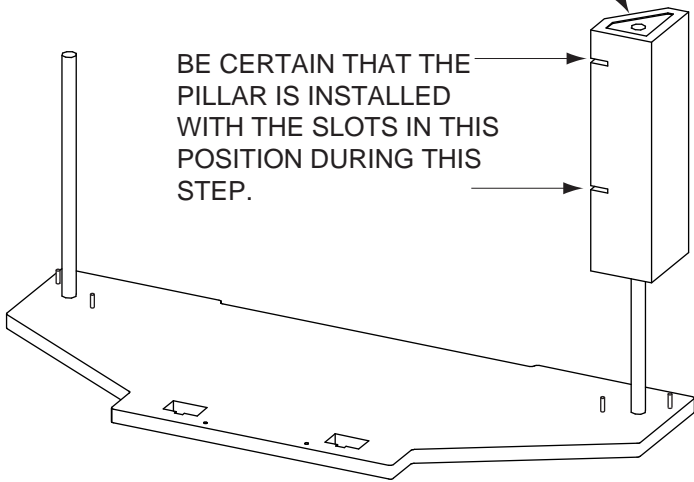

4

Then lower the other wood pillar into position over the other metal tube while guiding the remaining ends of the shelf frames into the holes in this pillar. See step 5 for more detail on this step. You should see a sticker that says 'Bottom' on the frames. This sticker should be facing up for this step.

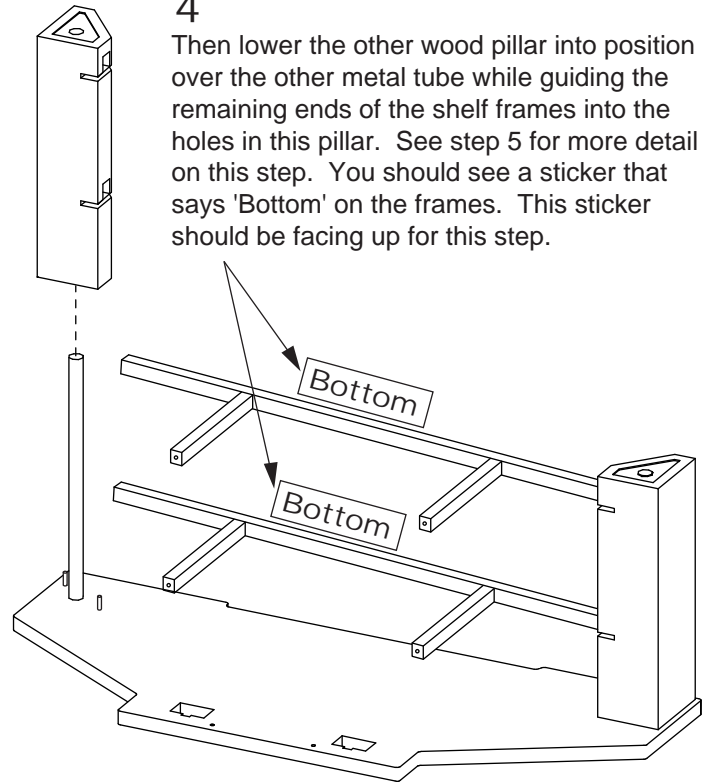

5

Gently guide the remaining ends of the frames into the holes in the remaining pillar while lowering it in place.

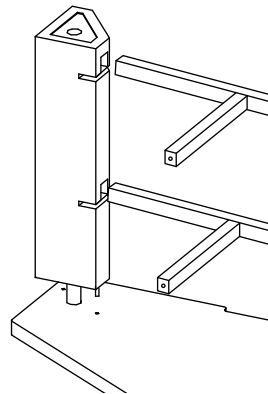

DP Plasma A/V Component Rack

Page 3 of 7

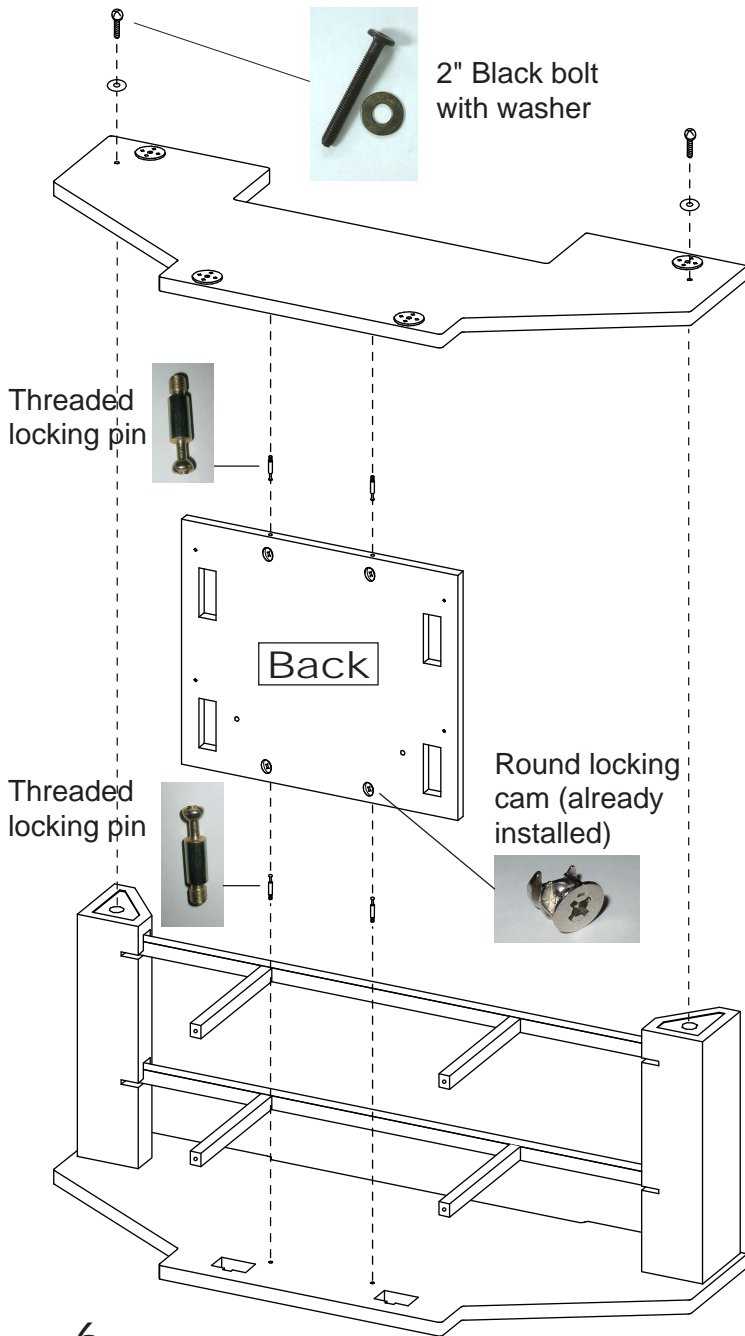

6

Next install 2 threaded pins into the top and bottom wood panels as shown here. Then lower the back panel over these pins and lock the panel in place by turning the cam insert in the back panel clockwise.

Then put the base of the rack on and secure it in place with the cam inserts in the back panel and bolts and washers in the wood pillars as shown here.

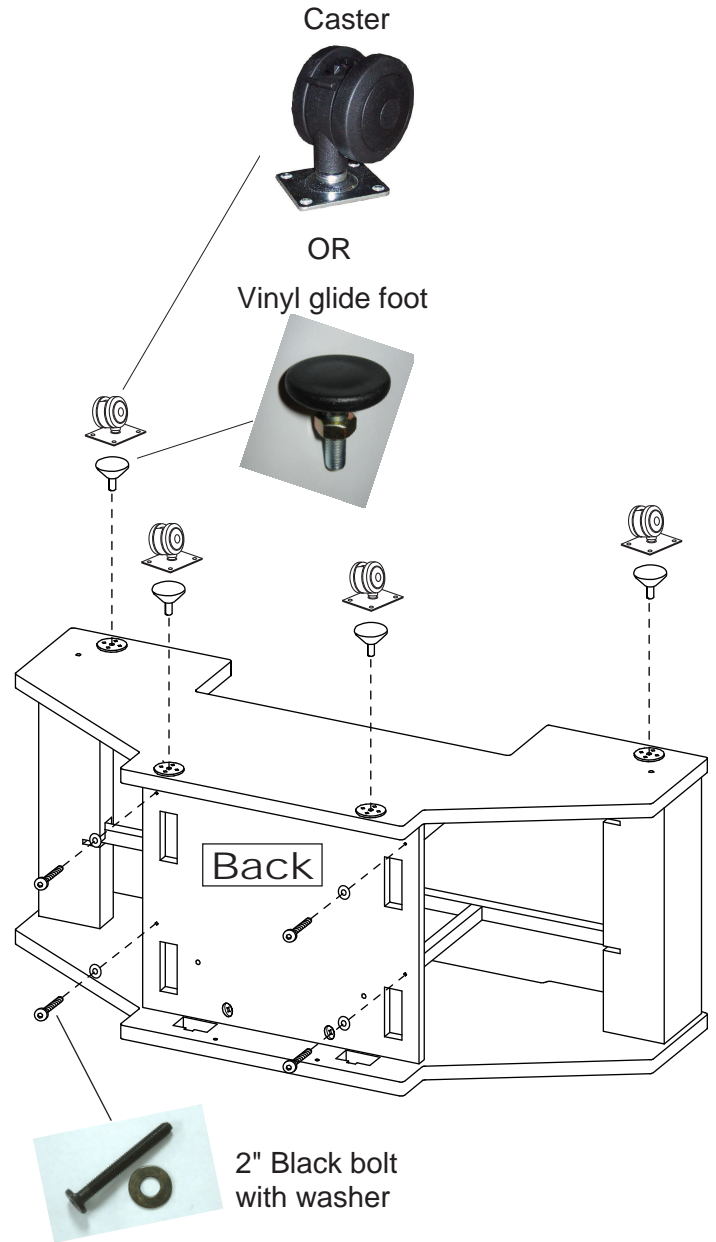

7

Install 4 2" bolts with washers through the back panel into the ends of the metal shelf support frames as shown here. Then install the 4 vinyl glide feet into the metal disks on the base as shown here.

NOTE: If you are using the optional rolling casters, install them in place of the vinyl glide feet. The casters are installed with 4 screws per caster in pre-drilled holes next to the metal disks used for the glide feet.

DP Plasma A/V Component Rack

Page 4 of 7

8

Turn the rack over and slide the glass shelves in place in the front of the rack as shown here. Once in place, secure each shelf with 2 bolts and washers each. NOTE: Do not overtighten these bolts. They can break the glass shelf if overtightened.

You will note that there are 2 holes in the shelf frames for the bolts along the back edge of the glass. If you require more depth for equipment you can pull the shelf forward and use the forward most holes to give more depth to the shelf.

If you are using the optional metal pillars and mounting board, proceed to step 9. If you are using the DP as a table top rack, install the wood caps into the holes otherwise used for the metal pillars as shown here.

Silver bolt
with washer

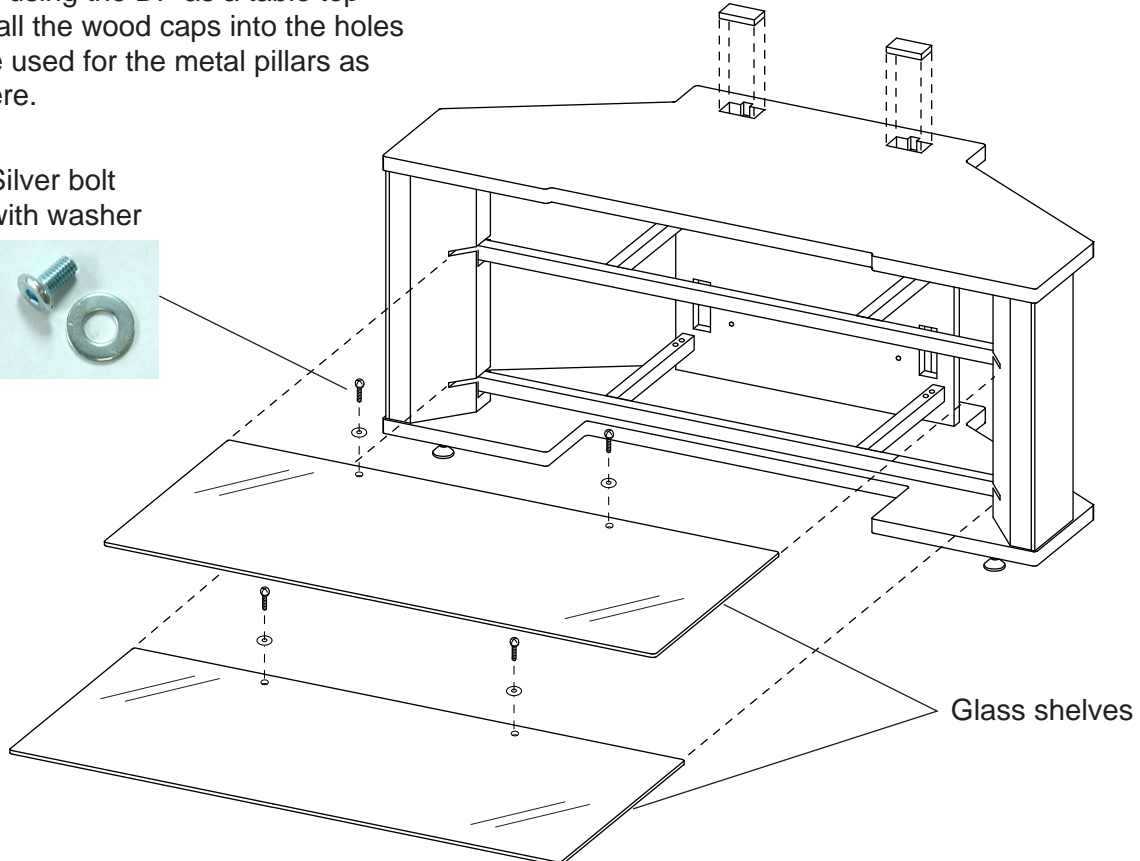

DP Plasma A/V Component Rack

Page 5 of 7

Optional metal pillars for mounting board.

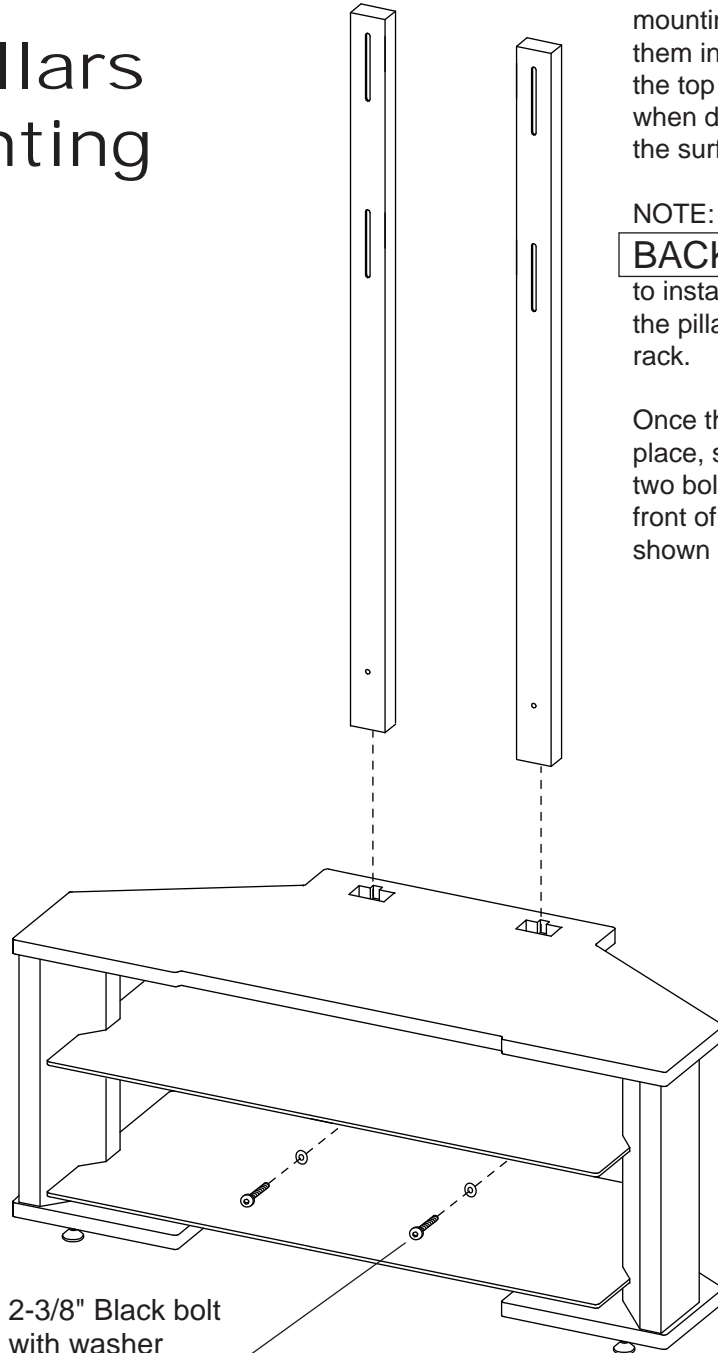

2-3/8" Black bolt
with washer



9

The metal pillars used with the mounting board install by sliding them into the holes in the back of the top shelf of the DP. Use caution when doing this as not to scratch the surface of the wood.

NOTE: The pillars should have a **BACK** sticker on them. Be sure to install the pillars with the back of the pillars facing the back of the rack.

Once the pillars are lowered in place, secure them to the rack with two bolts and washers through the front of the rack and back panel as shown here.

Optional mounting board

DP Plasma A/V Component Rack

Page 6 of 7

10

Attach the mounting board with bolts, washers and metal disks as shown here.

NOTE: THERE ARE 4 HOLES WITH THREADED INSERTS PRE-INSTALLED ON THE FRONT FOR THIS STEP BUT ATTACH THE MOUNTING BOARD WITH THE BACKSIDE FACING THE PILLARS.

BE CERTAIN TO ATTACH THE MOUNTING BOARD WITH THE BACK SIDE FACING THE PILLARS AS SHOWN HERE.

The slots in the pillars are designed to allow the mounting board to move up and down. Pick 2 of the 4 holes with the threaded inserts for this step depending on the height of the mounting board you require based on the size of the plasma you are mounting on the board. These holes are shown here as solid.

The mounting board is pre-drilled with holes that fit popular wall mounting hardware for plasma displays. This hardware must be purchased separately. The mounts typically come with a wall plate and a plasma frame. The wall plate attaches to the mounting board with bolts, washers and T nuts provided and shown below. Follow the instructions that come with the mount to attach the rest of the mounting hardware to the wall mount.

NOTE: FOR THIS STEP, BE CERTAIN THAT THE T NUTS ARE USED ON THE BACKSIDE OF THE MOUNTING BOARD AS SHOWN HERE.

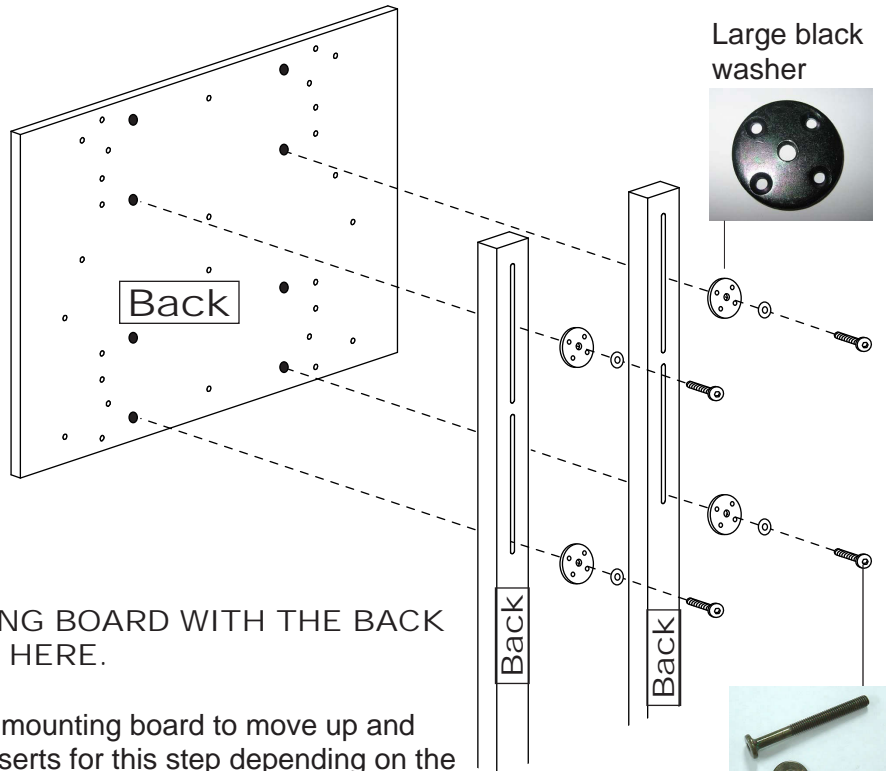

Large black washer



2-3/8" Bolt with washer

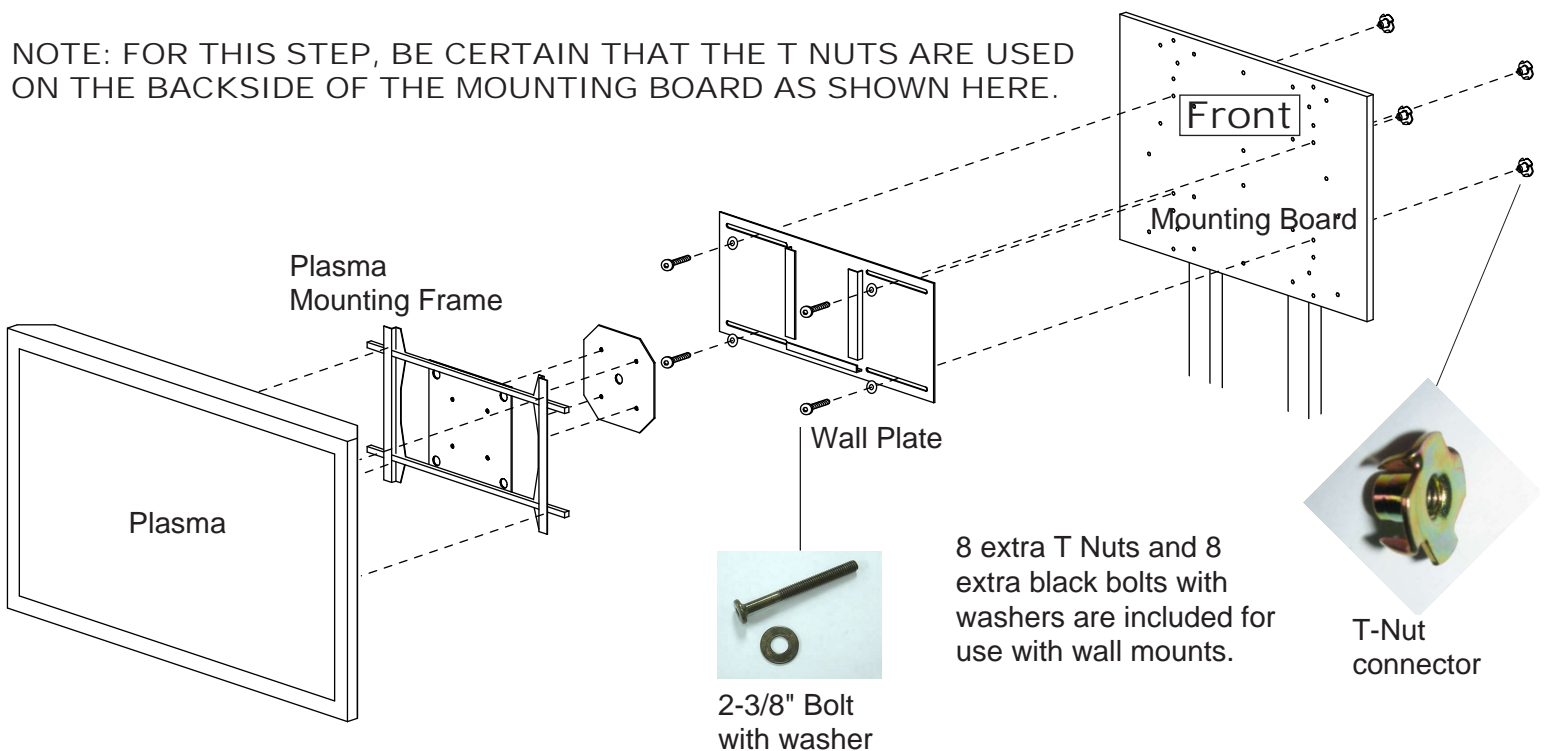

T Nuts on Backside of mounting board



T-Nut connector



2-3/8" Bolt with washer

8 extra T Nuts and 8 extra black bolts with washers are included for use with wall mounts.

DP Plasma A/V Component Rack

Parts List



6 PCS - 2" BLACK BOLT WITH WASHER.
(PART #1)



4 PCS - 1/2" SILVER BOLT WITH WASHER.
(PART #4)



2 PCS - 2" THREADED CONNECTOR.
(PART #5)



4 PCS - WOOD DOWEL. (PART #6)



4 PCS - 3/8" VINYL GLIDE FOOT. (PART #7)



4 PCS - THREADED LOCKING PIN. (PART #14)



4 PCS - ROUND LOCKING CAM. (PART #15)



2 PCS - WOOD CAP



1 PC - GOLD ALAN WRENCH. (PART #11)



8 PCS - BLACK PLASTIC CAP
(PART #16 - 6983)

Optional parts for rolling caster kit



4 PCS - ROLLING CASTER (2 PCS),
LOCKING ROLLING CASTER (2 PCS)



16 PCS - SCREWS FOR ROLLING CASTERS

Optional parts for mounting board & pillars



14 PCS - 2-3/8" BLACK BOLT WITH WASHER.



4 PCS - LARGE BLACK WASHER. (PART #8)



8 PCS - T-NUT CONNECTOR. (PART #10)



1 PC - GOLD ALAN WRENCH. (PART #11)