

CARTON CONTENTS

3 □ Wood Shelves	8 □ Carpet Spikes
8 □ 4" Tubes	□ with brass feet
8 □ 7" Tubes	□ and locking nuts
8 □ 9" Tubes	8 □ Brass Feet
8 □ A Connectors	8 □ Vinyl Glide Feet
16 □ B Connectors	□ Wire Snake

1

Begin assembly with the top shelf upside down. Be sure to put the top shelf on a soft surface as not to damage the finish of the top shelf. Next install the A-connectors as shown here with the small threaded end of the connector inserted into the wood shelf. It is important that you install the connector this way. If the long threads are used the connector may damage the top surface of the shelf. Then attach the 7" tubes to these connectors and twist in place. Do not over tighten these tubes.

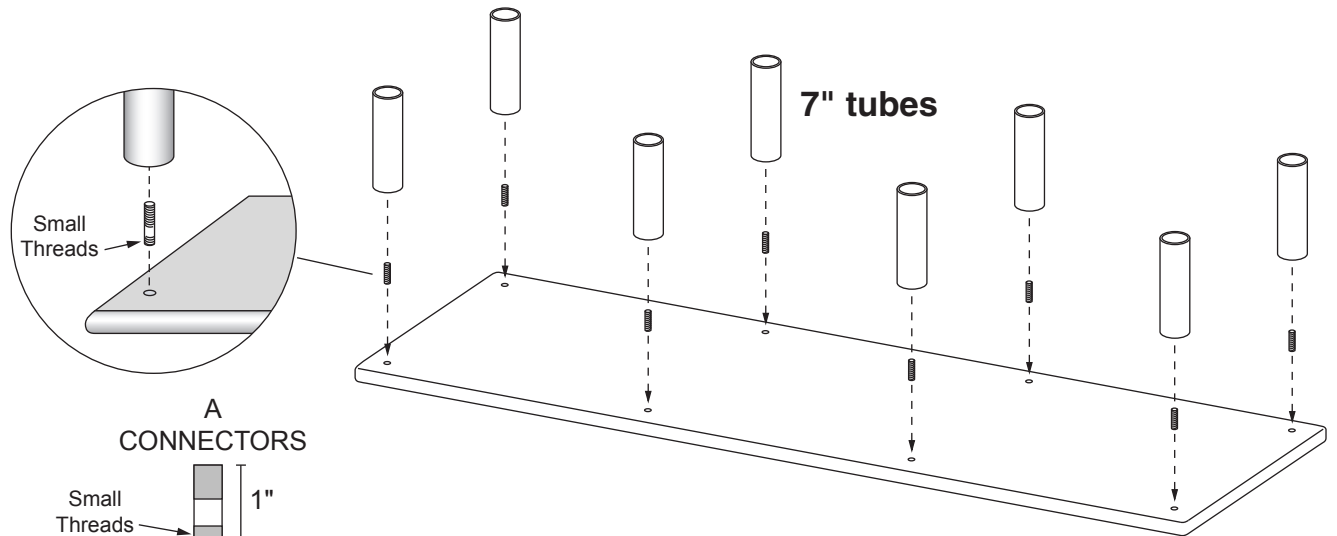

2

Next attach the 9" tubes with the B connectors as shown here.

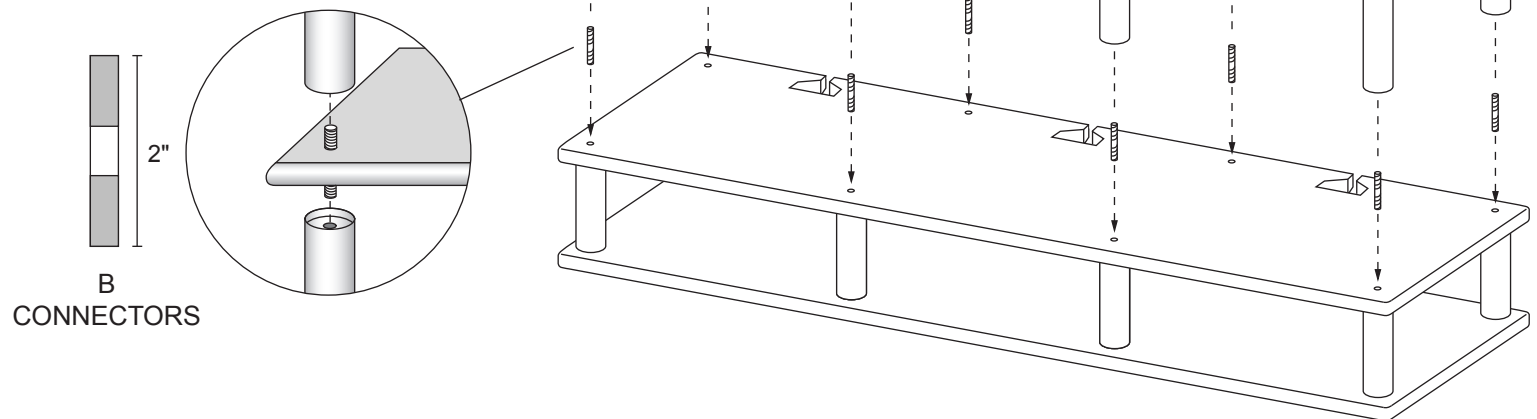

3

Next attach the 4" tubes with the B connectors as shown here.

All HF racks come standard with brass carpet spikes and vinyl glides (for hardwood floors). Rolling casters are optional and can be purchased from your local dealer or from StudioTech directly.

Vinyl Glide  OR  Carpet Spike

Optional
Rolling Caster

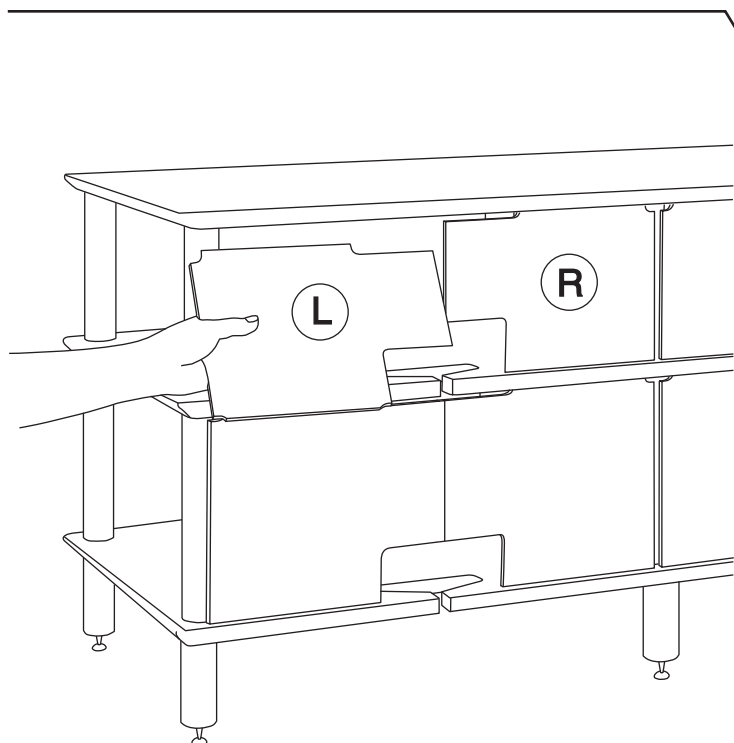
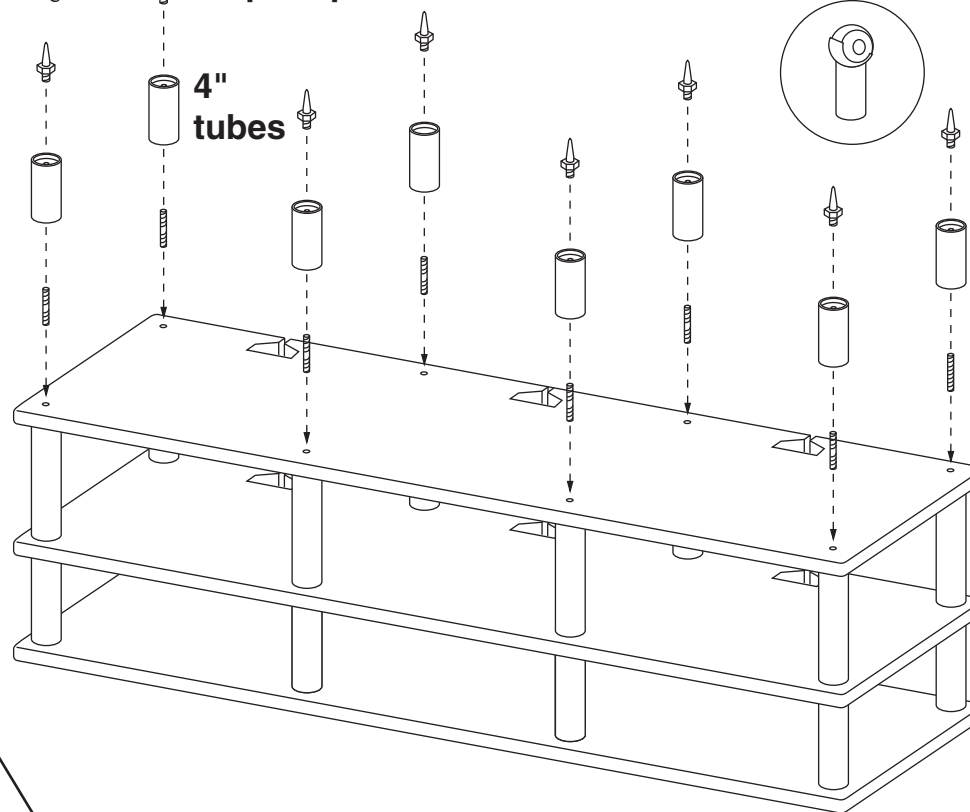

4

The back panels provided simply slip in the slots in each shelf as show here. Start by putting the top edge of the back panel into the underside of the shelf above. Then lower the panel into the slot in the top of the shelf below. Note that there is a right and left panel for each opening. Install as shown here.

Each shelf also has large wire openings in each shelf should you not choose to use the back panels. Our flexible plastic wire snake is also provided for additional cable management.

Limited Lifetime Warranty

Thank you for choosing StudioTech product.

StudioTech is a premier Audio/Video Furniture manufacturer and we offer a full line of Audio/Video Furniture. The product you have just purchased has been designed and manufactured with great care and attention to detail. We are pleased to offer you a Limited Lifetime Warranty on this product as outlined below.

Lifetime Warranty

StudioTech Inc., warrants to the original retail purchaser, that this product is to be free from defective materials and workmanship, when used in normal applications, for the life of the product. StudioTech warrants that it will repair or replace, at its option, any such defective product at no charge for parts or labor provided the product is delivered intact by the owner, postage prepaid to StudioTech. Inspection must disclose that all defects are as specified. If we repair this product, we may use new or remanufactured replacement parts. If we choose to replace this product, we may replace it with a new or remanufactured product of the same or similar design. If you are not registered in our Customer Care Program, Proof of Purchase is required. This Limited Warranty extends only to the original first retail purchaser of the product and is not assignable or transferable to any subsequent purchaser/end-user. No StudioTech dealer, agent, or employee is authorized to make any modification, extension, or addition to this warranty.

Limitations:

THIS WARRANTY AND REMEDIES SET FORTH HEREIN ARE EXCLUSIVE AND IN LIEU OF ALL OTHER WARRANTIES, REMEDIES AND CONDITIONS, WHETHER ORAL OR WRITTEN, EXPRESS OR IMPLIED. This warranty is limited to this StudioTech product and specifically excludes consequential damages to other components or premises which may result for any reason from the failure of the product. This warranty is null and void for products not used in accordance with StudioTech's instructions and shall also be null and void for products misused, neglected, abused, modified, altered or damaged by accident or otherwise not in accordance with StudioTech's instructions. This warranty does not cover cosmetic damage including paint damage by accidental or normal wear during use.

StudioTech assumes no liability for any costs or fees incurred for any services performed where nothing is wrong with the product, nor does StudioTech cover the cost of set up, installation, or adjustment. This warranty does not cover time,

transportation or compensate for inconvenience or loss of the product. In no event shall StudioTech be liable, whether in contract or tort (including negligence) for damages in excess of the purchase price of the product, or for any indirect, incidental, special or consequential damages of any kind, or loss of revenue or profits, loss of business, loss of information or data, or other financial loss arising out of or in connection with the ability or inability to use the product, to the full extent these damages may be disclaimed by law.

This warranty gives you specific legal rights, and you may also have other rights that vary by state or province. STUDIOTECH SPECIFICALLY DISCLAIMS ANY AND ALL IMPLIED WARRANTIES, INCLUDING, WITHOUT LIMITATION, WARRANTIES OF MERCHANTABILITY AND FITNESS FOR A PARTICULAR PURPOSE, OR OTHERWISE. STUDIOTECH, INC. SHALL IN NO CASE BE RESPONSIBLE FOR INCIDENTAL OR CONSEQUENTIAL DAMAGES OTHER THAN SET FORTH ABOVE. Some states do not allow limitations on how long a warranty applies and/or exclusions or limitations of incidental or consequential damages, so the above limitations may not apply to you.

Returns:

In the event you believe this StudioTech product may be defective in the course of the warranty period, you must contact StudioTech to receive Return Authorization. We will either ship you a replacement part for your product or we will issue an RA for you to return the product to us. Once you have received Return Authorization, you are responsible for delivery of product with a copy of the completed return authorization form and the original Bill of Sale, postage prepaid to StudioTech for repair or replacement. Remember to pack all parts carefully and in the original carton if possible and mark the RA # clearly on the outside of the carton near the address label. We suggest you insure the package as StudioTech is not responsible for loss or damage caused in shipment while product is in transit to StudioTech or by improper packaging. Additional charges may be added to product which requires new packaging materials for return shipment. No returns will be accepted without proper Return Authorization from StudioTech. This authorization may not be given by any other party. Unauthorized returns will be refused and the purchaser will be liable for shipping charges in both directions. Repaired product will be shipped back to you postage prepaid within the continental U.S.A. StudioTech reserves the right to make changes in warranty, product design, and specifications at any time.

Thank you again for purchasing StudioTech products.