



Owner's Manual and Instructions

"Big Bertha" Circulating Construction Heaters



MODELS	OUTPUT (Btuh)	FUEL
334	400,000	L.P. Gas Vapor Withdrawal
336	365,000	Natural Gas



Congratulations!

You have purchased the finest circulating construction heater available.

Your new L.B. White heater incorporates the benefits from the most experienced manufacturer of heating products using state-of-the-art technology.

We, at L.B. White, **thank you** for your confidence in our products and welcome any suggestions or comments you may have...call us, toll-free, at 1-800-345-7200.

ATTENTION ALL USERS

This heater has been tested and evaluated by L.B. White Co., Inc as a direct fired circulating construction heater with intended use for primarily the temporary heating of buildings under construction, alteration, or repair. If you are considering using this product for any applications other than its intended use, then please contact your fuel gas supplier or the L.B. White Co., Inc.



Quality heaters you can count on.

W6636 L.B. White Rd., Onalaska, WI 54650 ■ (800) 345-7200 ■ (608) 783-5691 ■ (608) 783-6115, fax ■ info@lbwhite.com



GENERAL HAZARD WARNING

- Failure to comply with the precautions and instructions provided with this heater, can result in:
 - Death
 - Serious bodily injury or burns
 - Property damage or loss from fire or explosion
 - Asphyxiation due to lack of adequate air supply or carbon monoxide poisoning
 - Electrical shock
- Read this Owner's Manual before installing or using this product.
- Only properly-trained service people should repair or install this heater.
- Save this Owner's Manual for future use and reference.
- Owner's Manuals and replacement labels are available at no charge. For assistance, contact L.B. White at 800-345-7200.



WARNING

- Proper gas supply pressure must be provided to the inlet of the heater.
- Refer to data plate for proper gas supply pressure.
- Gas pressure in excess of the maximum inlet pressure specified at the heater inlet can cause fires or explosions.
- Fires or explosions can lead to serious injury, death, or building damage.
- Gas pressure below the minimum inlet pressure specified at the heater inlet may cause improper combustion.
- Improper combustion can lead to asphyxiation or carbon monoxide poisoning and therefore serious injury or death.



WARNING

Fire and Explosion Hazard

- Not for home or recreational vehicle use.
- Installation of this heater in a home or recreational vehicle may result in a fire or explosion.
- Fire or explosions can cause property damage or loss of life.

FOR YOUR SAFETY

If you smell gas:

1. Open windows.
2. Don't touch electrical switches.
3. Extinguish any open flame.
4. Immediately call your gas supplier.

FOR YOUR SAFETY

Do not store or use gasoline or other flammable vapors and liquids in the vicinity of this or any other appliance.



WARNING

Fire and Explosion Hazard

- Keep solid combustibles a safe distance away from the heater.
- Solid combustibles include wood or paper products, building materials and dust.
- Do not use the heater in spaces which contain or may contain volatile or airborne combustibles.
- Volatile or airborne combustibles include gasoline, solvents, paint thinner, dust particles or unknown chemicals.
- Failure to follow these instructions may result in a fire or explosion.
- Fire or explosions can lead to property damage, personal injury or loss of life.



SECTION	PAGE
General Information	3
Heater Specifications	4
Safety Precautions	5
Installation Instructions	
General	7
Burner and Gas Control Installation	8
Hose and Regulator Assembly	9
Start-Up Instructions	9
Shut-Down Instructions	9
Cleaning Instructions	10
Maintenance Instructions	10
Troubleshooting Information	14
Heater Component Function	15
Parts Identification	
Parts Schematic	16
Parts List	17
Warranty Policy	18
Replacement Parts and Service	18

General Information

This Owner's Manual includes all options and accessories commonly used on this heater. However, depending on the configuration purchased, some options and accessories may not be included.

When calling for technical service assistance, or for other specific information, always have model number, configuration number and serial number available. This information is contained on the dataplate.

This manual will instruct you in the operation and care of your unit. Have your qualified installer review this manual with you so that you fully understand the heater and how it functions.

The gas supply line installation, installation of the heater, and repair and servicing of the heater requires continuing expert training and knowledge of gas heaters and should not be attempted by anyone who is not so qualified. See page 6 for definition of the necessary qualifications.

Contact your local L.B. White distributor or the L.B. White Co., Inc. for assistance, or if you have any questions about the use of the equipment or its application.

The L.B. White Co., Inc. has a policy of continuous product improvement. It reserves the right to change specifications and design without notice.

Heater Specifications

SPECIFICATIONS	Model	
	334	336
Fuel Type	L.P. Gas	Natural Gas
Maximum Input (BTUH)	400,000	365,000
Ventilation Air Required to Support Combustion	1,600 CFM	1,600 CFM
Inlet Gas Supply Pressure Acceptable at the Inlet of the Pilot Safety Control Valve (PSIG)	MAX.	18
	MIN.	18
Fuel Consumption Per Hour	18.5 lbs.	336 cu. ft.
Sleeve Bearing		
Motor Characteristics	1/4 H.P. 1725 RPM	
Electrical Supply (Volts/Hz/Phase)	115/60/1	
Amp Draw	STARTING	12.0
	CONTINUOUS OPERATION	4.0
Dimensions (Inches) L x W x H	46 x 35 x 25	
Minimum Safe Distances From Nearest Combustible Materials	TOP	7 ft.
	SIDES	5 ft.
	BACK	5 ft.
	BLOWER OUTLET	9 ft.
	GAS SUPPLY	L.P. Gas Supply - 6 ft.
Net Weight (lbs.)	150	155
Shipping Weight (lbs.)	156	161

Safety Precautions

WARNING **Asphyxiation Hazard**

- Do not use this heater for heating human living quarters.
- Do not use in unventilated areas.
- The flow of combustion and ventilation air must not be obstructed.
- Proper ventilation air must be provided to support the combustion air requirements of the heater being used.
- Refer to the specification section of the heater's Owner's Manual, heater dataplate, or contact the L.B. White Company to determine combustion air ventilation requirements of the heater.
- Lack of proper ventilation air will lead to improper combustion.
- Improper combustion can lead to carbon monoxide poisoning leading to serious injury or death. Symptoms of carbon monoxide poisoning can include headaches, dizziness and difficulty in breathing.

FUEL GAS ODOR

LP gas and natural gas have man-made odorants added specifically for detection of fuel gas leaks.

If a gas leak occurs, you should be able to smell the fuel gas.

THAT'S YOUR SIGNAL TO GO INTO IMMEDIATE ACTION!

- Do not take any action that could ignite the fuel gas. Do not operate any electrical switches. Do not pull any power supply or extension cords. Do not light matches or any other source of flame. Do not use your telephone.
- Get everyone out of the building and away from the area immediately.
- Close all propane (LP) gas tank or cylinder fuel supply valves, or the main fuel supply valve located at the meter if you use natural gas.
- Propane (LP) gas is heavier than air and may settle in low areas. When you have reason to suspect a propane leak, keep out of all low areas.
- Use your neighbor's phone and call your fuel gas supplier and your fire department. Do not re-enter the building or area.
- Stay out of the building and away from the area until declared safe by the firefighters and your fuel gas supplier.
- **FINALLY**, let the fuel gas service person and the firefighters check for escaped gas. Have them air out the building and area before you return. Properly trained service people must repair the leak, check for further leakages, and then relight the appliance for you.

ODOR FADING -- NO ODOR DETECTED

- **Some people cannot smell well. Some people cannot smell the odor of the man-made chemical added to propane (LP) or natural gas. You must determine if you can smell the odorant in these fuel gases.**
- Learn to recognize the odor of propane (LP) gas and natural gas. Local propane (LP) gas dealers will be more than happy to give you a scratch and sniff pamphlet. Use it to become familiar with the fuel gas odor.
- Smoking can decrease your ability to smell. Being around an odor for a period of time can affect your sensitivity to that particular odor. Odors present in animal confinement buildings can mask fuel gas odor.
- The odorant in propane (LP) gas and natural gas is colorless and the intensity of its odor can fade under some circumstances.
- If there is an underground leak, the movement of gas through the soil can filter the odorant.
- Propane (LP) gas odor may differ in intensity at different levels. Since propane (LP) gas is heavier than air, there may be more odor at lower levels.
- **Always be sensitive to the slightest gas odor.** If you continue to detect any gas odor, no matter how small, treat it as a serious leak. Immediately go into action as discussed previously.

ATTENTION -- CRITICAL POINTS TO REMEMBER!

- Propane (LP) gas has a distinctive odor. Learn to recognize these odors. (Reference Fuel Gas Odor and Odor Fading sections above.)
- If you have not been properly trained in repair and service of propane (LP) gas then do not attempt to light heater, perform service or repairs, or make any adjustments to the heater on the propane (LP) gas fuel system.
- Even if you are not properly trained in the service and repair of the heater, ALWAYS be consciously aware of the odors of propane (LP) gas and natural gas.
- A periodic sniff test around the heater or at the heater's joints; i.e. hose, connections, etc., is a good safety practice under any conditions. If you smell even a small amount of gas, CONTACT YOUR FUEL GAS SUPPLIER IMMEDIATELY. DO NOT WAIT!

1. Do not attempt to install, repair, or service this heater or the gas supply line unless you have continuing expert training and knowledge of gas heaters.

Qualifications for service and installation of this equipment are as follows:

- a. To be a qualified gas heater service person, you must have sufficient training and experience to handle all aspects of gas-fired heater installation, service and repair. This includes the task of installation, troubleshooting, replacement of defective parts and testing of the heater. You must be able to place the heater into a continuing safe and normal operating condition. You must completely familiarize yourself with each model heater by reading and complying with the safety instructions, labels, Owner's Manual, etc., that is provided with each heater.
 - b. To be a qualified gas installation person, you must have sufficient training and experience to handle all aspects of installing, repairing and altering gas lines, including selecting and installing the proper equipment, and selecting proper pipe and tank size to be used. This must be done in accordance with all local, state and national codes as well as the manufacturer's requirements.
2. All installations and applications of L.B. White heaters must meet all relevant local, state and national codes. Included are L.P. gas, natural gas, electrical, and safety codes. Your local fuel gas supplier, a local licensed electrician, the local fire department or similar government agencies, or your insurance agent can help you determine code requirements.
 - ANSI/NFPA 58, latest edition, Standard for Storage and Handling of Liquefied Petroleum Gas and/or
 - ANSI Z223.1/NFPA 54, National Fuel Gas Code
 - ANSI/NFPA 70, National Electrical Code.
 3. We cannot anticipate every use which maybe made of our heaters. Check with the local fire safety authority if you have questions about applications.
 4. Forced air heaters shall not be directed toward any LP gas container within 20 feet (6.10 meters). Do not wash the heater. Use only compressed air, a soft brush or dry cloth to clean the interior of the heater and it's components.
 5. The heater shall be installed so that it is not directly exposed to water spray, rain, or dripping water.
 6. Do not locate fuel gas containers or fuel supply hoses anywhere near the blower outlet of the heater.

7. Do not block air intakes or discharge outlets of the heater. Doing so may cause improper combustion or damage to heater components leading to property damage.
8. The hose assembly shall be visually inspected on a daily basis after heater relocation and when the heater is in use. If it is evident there is excessive abrasion or wear, or if the hose is cut, it must be replaced prior to the heater being put into operation. The hose assembly shall be protected from building materials, and contact with hot surfaces during use. The hose assembly shall be that specified by the manufacturer. See parts list.
9. Check for gas leaks and proper function upon heater installation, when relocating, and after servicing. Refer to leak check instructions within installation section of this manual.
10. This heater should be inspected for proper operation by a qualified service person before each use and at least annually.
11. Always turn off the gas supply to the heater if the heater is not going to be used in the heating of the work space.
12. This heater is equipped with a three-prong (grounding) plug for your protection against shock hazard and must be plugged directly into a properly grounded three-prong receptacle. Failure to use a properly grounded receptacle can result in electrical shock, personal injury, or death.
13. If gas flow is interrupted and flame goes out, do not relight the heater until you are that all gas that may have accumulated has cleared away. In any event, do not relight the heater for at least 5 minutes.
14. Minimum LP gas supply cylinder size to be used shall be 3 (three) - 100 pound cylinders properly manifolded together for single point withdrawal. When using a cylinder supply system, the system must be arranged to provide vapor withdrawal from the operating cylinder.
15. When the heater is to be stored indoors, the connection between the L.P. gas supply cylinder(s) and the heater must be disconnected and the cylinder(s) removed from the heater and stored in accordance with Chapter 5 if the Standard for the Storage and Handling of Liquefied Petroleum Gases, ANSI/NFPA 58.
16. L.P. gas supply containers have left handed threads. Always use the appropriate wrench to make a connection to tighten or loosen the P.O.L. fitting at the cylinders' gas supply valve.



WARNING

Fire and Explosion Hazard

Can cause property damage, severe injury or death

1. To avoid dangerous accumulation of fuel gas, turn off gas supply at the heater service valve before starting installation, and perform gas leak test after completion of installation.
2. Do not force the gas control pilot button. Use only your hand to depress the pilot button. Never use any tools. If the button will not operate by normal hand pressure the control should be replaced by a qualified service technician. Force or attempted repair may result in fire or explosion.

1. Read all safety precautions and follow L. B. White recommendations when installing this heater. If during the installation or relocating of heater, you suspect that a part is damaged or defective, call a qualified service agency for repair or replacement.
2. Make sure the heater is properly installed before use. Observe and obey all minimum safe distances of the heater to the nearest combustible materials. Safe distances are given on the heater dataplate and on page 4 of this manual.
3. The heater is approved for indoor use only.
4. The heater shall not be used with ductwork.
5. The heater's gas pressure regulator (with pressure relief valve) must be protected from adverse weather conditions (rain, ice, snow) as well as from building materials (tar, concrete, plaster, etc.) which can affect safe operation and could result in property damage or injury.
6. Heaters used in the vicinity of combustible tarpaulins, canvas, plastics, wind barriers, or similar coverings shall be located at least 10 feet from the coverings. The coverings shall be securely fastened to prevent ignition or upsetting of the heater due to wind action on the covering or other material.

ATTENTION

Check all connections for gas leaks using approved gas leak detectors. Gas leak testing is performed as follows:



WARNING

Fire and Explosion Hazard

- Do not use open flame (matches, torches, candles, etc.) in checking for gas leaks.
- Use only approved leak detectors.
- Failure to follow this warning can lead to fires or explosions.
- Fires or explosions can lead to property damage, personal injury or loss of life.

- Check all pipe connections, hose connections, fittings and adapters upstream of the gas control with approved gas leak detectors.
- In the event a gas leak is detected, check the components involved for cleanliness and proper application of pipe compound before further tightening.
- Furthermore tighten the gas connections as necessary to stop the leak.
- After all connections are checked and any leaks are stopped, turn on the main burner.
- Stand clear while the main burner ignites to prevent injury caused from hidden leaks that could cause flashback.
- With the main burner in operation, check all connections, hose connections, fittings and joints as well as the gas control valve inlet and outlet connections with approved gas leak detectors.
- If a leak is detected, check the components involved for cleanliness in the thread areas and proper application of pipe compound before further tightening.
- Tighten the gas connection as necessary to stop the leak.
- If necessary, replace the parts or components involved if the leak cannot be stopped.
- Ensure all gas leaks have been identified and repaired before proceeding.

7. A qualified service agency must check for proper operating gas pressure upon installation of the heater.
8. Light according to instructions on heater or within owner's manual.
9. Make sure the heater has the proper gas regulator for the application. A regulator must be connected to the gas supply so that gas pressure at the inlet to the gas valve is regulated within the range specified on the dataplate at all times. Contact your gas supplier, or the L.B. White Co., Inc. if you have any questions.
10. This heater is configured for use for L.P. gas vapor withdrawal or natural gas. Do not use the heater in an L.P. gas liquid withdrawal system or application. If you are in doubt, contact the L.B. White Co., Inc.
11. Eventually, like all electrical/mechanical devices, the thermostat can fail. For heaters so equipped, thermostat failure may result in an underheating condition which may allow or cause damage to construction materials, such as cement or drywall. The thermostat should be tested to make sure it turns the heater on and off within a temperature differential of $\pm 3^{\circ}\text{F}$.
12. Take time to understand how to operate and maintain the heater by using this Owner's Manual. Make sure you know how to shut off the gas supply to the building and also to the individual heater. Contact your fuel gas supplier if you have any questions.
13. Any defects found in performing any of the service or maintenance procedures must be eliminated and defective parts replaced immediately. The heater must be retested by properly qualified service personnel before placing the heater back into use.

BURNER AND GAS CONTROL ASSEMBLY INSTALLATION

1. Place the preassembled burner and gas control assembly in the channel located in bottom of heater so:
 - Two tabs of channel are located within venturi openings of burner head. See Fig. 1.
 - Manual main burner valve on torch is facing up. See Fig. 1.
 - Torch handle is positioned into torch hold down bracket. See Fig. 1 & 2.
2. Secure torch into position by tightening bolt. See Fig. 2.

FIG. 1

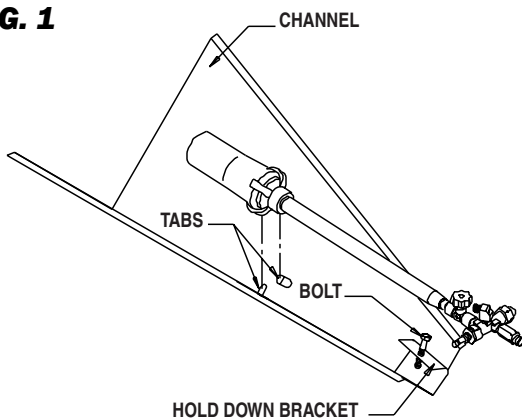
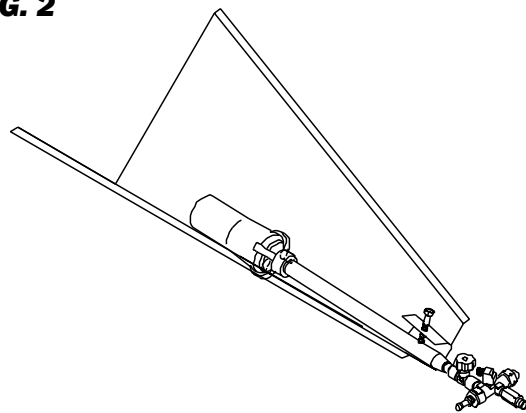

FIG. 2



THERMOSTAT INSTALLATION

WARNING
Electrical Shock Hazard

- Disconnect the electrical supply before connecting the thermostat to the heater.
- Failure to follow this warning can result in electrical shock, leading to personal injury or death.

Optional thermostatic control kits are available as field installed accessories. Installation instructions are provided with each kit. The kit part numbers are as follows:

Model	Kit Part
334	500-00015
336	500-00019

MANUAL SHUT-OFF VALVE, HOSE AND REGULATOR ASSEMBLY

1. Always use approved pipe thread compound suitable for use with L.P. gas or natural gas on the threaded connections.
2. Assemble the components together according to the figure. This view is to show general assembly of the components only.
3. Tighten all connections securely.
4. **Check all connections for gas leaks using approved gas leak detectors.**

FIG. 3

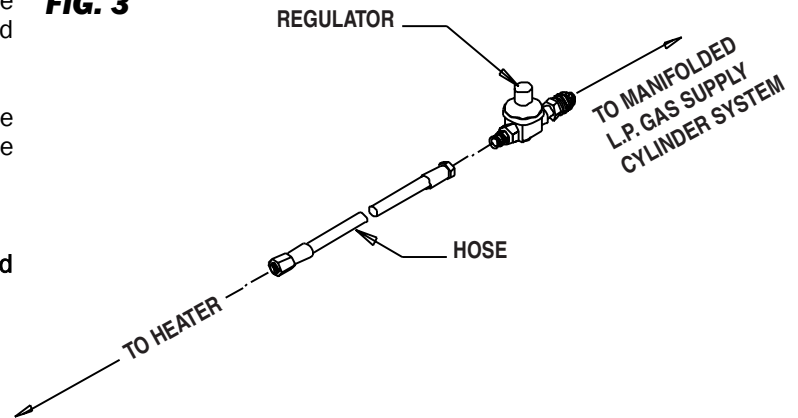

Start-Up Instructions

WARNING
Burn Hazard

- Close the manual main burner valve before lighting the pilot.
- Failure to do so will result in the main burner igniting when the pilot is being lit.
- Serious injury or death by burns may occur.

1. Slowly open the LP Gas supply container valve.
2. Fully depress the button on the pilot safety control valve while applying flame to the pilot.

ATTENTION

- On new installations it may take a short time for gas to purge out any air in the pilot line before the pilot stays lit.
3. Keep the pilot button depressed for about 30 seconds to allow the thermocouple to warm up so the pilot stays lit after the pilot button is released.

4. Connect the heater's power cord to an approved electrical supply.
5. Fully open the manual main burner valve located between electrical solenoid valve and burner. The main burner will light.

FIG. 4

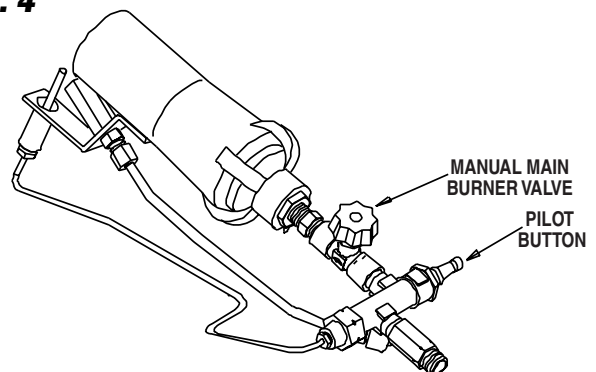

Shut-Down Instructions

1. Close the gas supply valve located on the LP gas supply container.
2. Allow the heater to burn off any fuel gas remaining in the gas supply line.
3. Close the manual main burner valve on the heater.
4. Disconnect the heater from its gas and electrical supplies.

Cleaning Instructions



WARNING Fire, Burn, and Explosion Hazard

- This heater contains electrical and mechanical components in the gas management, and safety systems.
- Such components may become inoperative or fail due to dust, dirt, wear and aging.
- Periodic cleaning and inspection as well as proper maintenance are essential to avoid serious injury or property damage.

1. Before cleaning, shut off all gas supply valves and disconnect electrical supply.
2. The heater should have dirt or dust removed periodically:
 - a. Before each use give the heater a general cleaning using compressed air or a soft brush or dry rag on its case and internal components. At this time, dust off the motor case to prevent the motor from over-heating.
 - b. At least once a year, give the heater a thorough cleaning. At this time, remove the fan and motor assembly and brush or blow off the fan blade assembly. Additionally, make sure the burner casting is free of dust accumulation.



WARNING

Do not use a pressure washer, water, or liquid cleaning solution on any gas controls. Use of a pressure washer, water, or liquid cleaning solution on the control components can cause severe personal injury or property damage due to water and/or liquids:

- * In electrical components, and wires causing electrical shock or equipment failure.
- * On gas control valves causing corrosion which can result in gas leaks and fire or explosion from the leak.

Clean all components of the heater with pressurized air, a dry brush or a dry cloth.

Maintenance Instructions

1. The area surrounding the heater shall be kept clear and free from combustible materials, gasoline, and other flammable vapors and liquids.
2. Have your gas supplier check all gas piping annually for leaks or restrictions in gas lines.
3. Regulators must be periodically inspected to make sure the regulator vents are not blocked. Debris, insects, insect nests, snow, or ice on a regulator can block vents and cause excess pressure at the appliance.
4. Regulators can wear out and function improperly. Have your gas supplier check the date codes on all regulators installed and check delivery pressures to the appliance to make sure that the regulator is reliable.
5. Check all wiring associated terminals and electrical components within the heater for corrosion, frayed or cut insulation, tight connections, etc. Repair or replace as necessary.
6. Review all heater markings (i.e. warnings, start-up, shut-down, etc.) at the time of maintenance for legibility. Make sure none are cut, torn, or otherwise damaged. Any damaged markings must be replaced immediately by contacting the L.B. White Co., Inc. Dataplates, start-up and shut-down instructions and warnings are available at no cost. A nominal charge will be applied for wiring diagrams.
7. The motor should be oiled prior to the heating season. Remove the oil port plugs and place several drops of SAE 20 non-detergent oil in each port.

Service Instructions

A. BURNER ORIFICE

1. Initial Preparation
 - a. Close fuel supply valves to heater.
 - b. Allow heater to burn off remaining fuel in its gas supply line.
 - c. Disconnect hose from heater.
 - d. Allow heater to cool.
2. Orifice Removal
 - a. Loosen retaining bolt which secures burner assembly to burner channel. Pull burner assembly from heater.
 - b. Disconnect compression nut from brass elbow at pilot control valve and thermocouple from pilot control valve. See Fig. 5.

FIG. 5

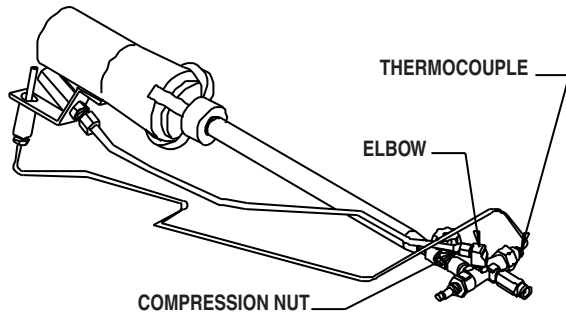

- c. Carefully reposition pilot line and thermocouple away from safety control valve.
- d. Disassemble the following: See Fig. 6.
 - Pilot control with manual valve from inlet of torch handle using appropriate wrench.
 - Torch handle from burner casting. Use a pipe wrench.
 - Burner orifice from burner casting. Use a 1/2 in. socket.

FIG. 6

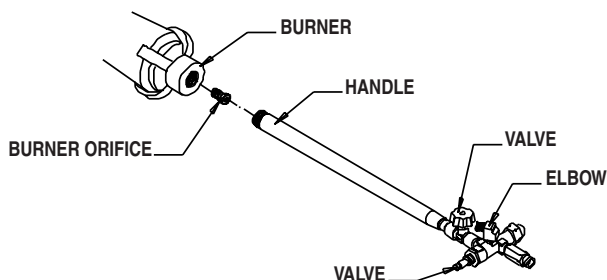

- e. Ensure orifice hole is not plugged with dirt or other materials. Clean the burner orifice or replace if necessary.

ATTENTION

- Use only a soft brush, a dry rag, or compressed air to clean the burner orifice.
- Do not push instruments into the orifice hole. Doing so may enlarge or distort the hole, creating improper combustion.

3. Completion

- a. To assemble, reverse these procedures.
- b. Tighten all connections securely.
- c. Open fuel supply valves to the heater.
- d. Light the heater and check for gas leaks.

B. PILOT ASSEMBLY

1. Initial Preparation

- a. Close fuel supply valves to heater.
- b. Allow heater to burn off remaining fuel in its gas supply line.
- c. Disconnect hose from heater.
- d. Allow heater to cool.

2. Pilot Orifice

- a. Using the appropriate wrench, loosen compression nut at pilot orifice and carefully reposition pilot tube away from the orifice. See Fig. 7.
- b. Remove pilot orifice from pilot head.

(Continued on page 12)

FIG. 7

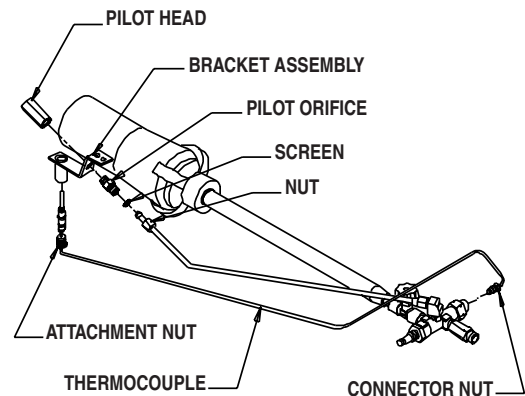

- c. Remove the pilot orifice screen at the inlet of the orifice prior to cleaning. Reinstall the screen after cleaning.
- d. Ensure pilot orifice holes are not plugged with dirt or other materials. Clean the pilot orifice or replace if necessary. The replacement orifice ships with an orifice screen.

ATTENTION

- Do not insert sharp instruments into the pilot orifice hole.
- Clean the orifice only with compressed air, soft brush, or dry rag.

3. Thermocouple

- a. Using appropriate wrench, loosen the thermocouple's attachment nut at thermocouple holder on pilot bracket. See Fig. 7.
- b. Loosen thermocouple connector nut from pilot safety control valve.
- c. Remove thermocouple from burner assembly.

ATTENTION

- Do not use pliers when removing or tightening the thermocouple's attachment or connector nuts. Doing so will round off the nuts creating service problems. Always use the appropriate wrench.
- Ensure the thermocouple is fully and firmly positioned in the pilot bracket by its attachment nut.
- Do not make sharp kinks or bends in the thermocouple lead. Doing so may damage the thermocouple.
- Thread the thermocouple's connector nut into the safety control valve fingertight. Snug it in place with appropriate wrench.

4. Completion

- a. To assemble, reverse these procedures.
- b. Tighten all gas connections securely.
- c. Open fuel supply valves to the heater.

C. MOTOR AND FAN ASSEMBLY

1. Initial Preparation

- a. Close fuel supply valves to heater.
- b. Disconnect heater from its electrical supply.

2. Motor and Fan Assembly Removal

- a. Remove the four bolts which secure the motor to the motor mounting bracket. See Fig 8.
- b. Pull motor and fan assembly from heater.
- c. Loosen set screw on hub of fan.
- d. Pull fan blade from motor shaft.
- e. To assemble, reverse these procedures.

FIG. 8

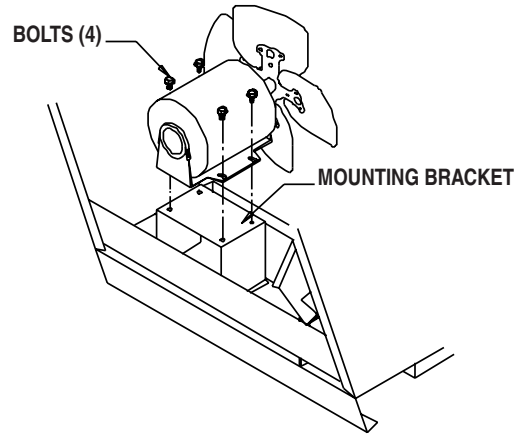

ATTENTION

- Ensure set screw of fan is positioned at flat of motor shaft before tightening.
- Position fan before tightening set screw so its hub is flush with end of motor shaft. See Fig 9.

FIG. 9

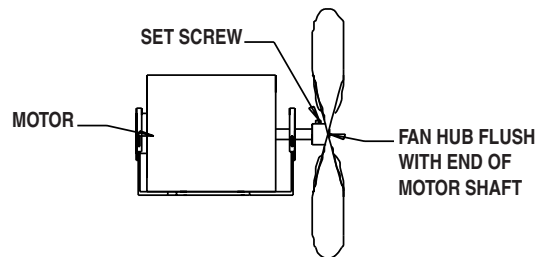

Gas Pressure Checks

ATTENTION

This procedure is to be done once a year prior to the heating season, anytime the heater is moved from one job location to the next, or after servicing the heater.

WARNING

- Do not disassemble the pilot safety control valve.
- Do not attempt to replace any components of the pilot safety control valve.
- The pilot safety control must be replaced if any physical damage occurs to it.
- Failure to follow this warning will result in fire or explosions, leading to injury or death, and building damage.

MATERIALS REQUIRED

(To be secured through local purchase)

Quantity	Description
1	High Pressure Gas Gauge capable of reading up to 35 PSIG
1	1/4 in. Tee
1	1/4 in. Nipple

A. PREPARATION

1. Close fuel supply valve at LP gas supply container.
2. Allow heater to burn off gas remaining in it's gas supply line..
3. Close manual main burner valve on heater.
4. Remove gas hose from heater.
5. Remove hose adapter from inlet of pilot safety control valve.

B. GAUGE INSTALLATION

1. Connect the following materials together in the order as given. See Fig. 10.
 - Tee to inlet of pilot safety control.
 - Nipple to tee.
 - Hose adapter (as removed earlier) to nipple.
 - Gas hose to hose adapter.

FIG. 10

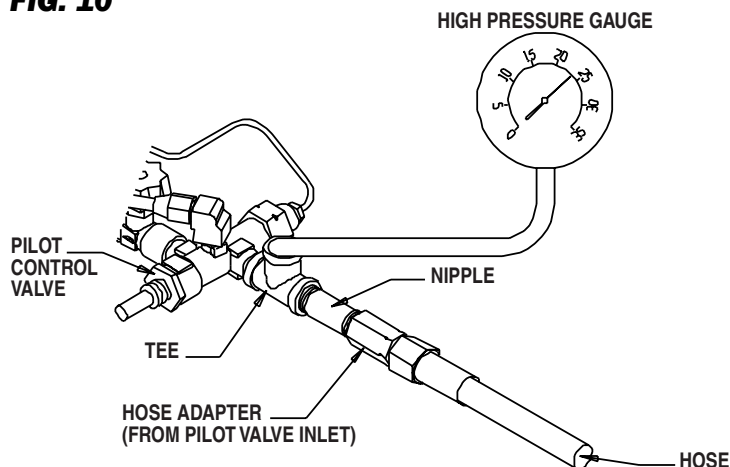

2. Tighten all connections securely.
3. Connect gauge to tee.

C. READING PRESSURES

1. Start the heater. With the heater operating, the pressure gauge should read the pressure specified on the dataplate or in the specification section of this owner's manual.
2. Does the pressure reading at the inlet of the safety control agree with that given on the dataplate? If so, no further checking or adjustment is required. Proceed to section D.
3. If the inlet pressures do not agree with that specified on the dataplate, then check the following:
 - Improper regulator for heater.
 - Blockage in gas hose.
 - Insufficient size or quantity of LP gas supply containers.

D. COMPLETION

1. Once the proper inlet pressure has been confirmed, close fuel supply valves.
2. Allow heater to burn off fuel remaining in gas supply line.
3. Remove gauge, hose adapter, nipple and tee.
4. Reconnect hose adapter to inlet of safety control valve and hose to hose adapter.
5. Tighten all connection securely and check for gas leaks.

Troubleshooting Information

<u>PROBLEMS</u>	<u>CAUSES</u>	<u>REMEDIES</u>
1. Pilot will not light.	<ul style="list-style-type: none"> * LP-Gas tank empty. * Gas supply valve closed. * Pilot control valve button not fully depressed. * Restriction in gas hose. * Pilot light orifice or screen plugged. * Air in gas line. * Excess flow valve in P.O.L. stem closed. * Pilot control valve defective. 	<ul style="list-style-type: none"> * Fill LP-Gas tank. * Open supply valve. * Fully depress the pilot button. * Replace hose or blow out with compressed air. * Clean orifice or screen with compressed air, or replace orifice or screen if necessary. * Depress pilot button on pilot control valve to bleed the air from the gas line. Usually necessary at time of installation. * Close LP-Gas tank valve, wait 5 minutes and reopen valve slowly. * Replace pilot control valve.
2. Pilot light will not stay lit when pilot control valve is released.	<ul style="list-style-type: none"> * Restriction in gas hose. * Loose thermocouple. * Weak or defective thermocouple. * Pilot light orifice or screen partially plugged. * Defective pilot control valve. * Debris plugging up pilot screen. 	<ul style="list-style-type: none"> * Replace hose or blow out with compressed air. * Tighten thermocouple.(1) * Replace thermocouple.(1) * Clean orifice or screen with compressed air replace pilot orifice or screen if necessary. * Replace pilot control valve. * Replace pilot screen.
3. Pilot light will not stay lit when main burner and blower are operating.	<ul style="list-style-type: none"> * Pilot light orifice or screen partially plugged. * Improper gas pressure. * Weak or defective thermocouple. * Loose thermocouple. 	<ul style="list-style-type: none"> * Clean orifice or screen with compressed air or replace pilot orifice or screen if necessary. * Set pressure according to Owner's Manual or dataplate on heater. * Replace thermocouple.(1) * Tighten thermocouple connection.(1)
4. Heater blowing cold air with pilot light out.	<ul style="list-style-type: none"> * LP-Gas tank empty. * Obstruction in gas line. * Freeze up of LP gas tank. 	<ul style="list-style-type: none"> * Fill LP-Gas tank. * Clean the gas line. * Use larger LP gas tank. Keep tank full on cold nights.
5. Motor overheating and shutting off.	<ul style="list-style-type: none"> * Thermal overload switch in motor is opening. 	<ul style="list-style-type: none"> * Thermal overload switch in motor opening due to: <ul style="list-style-type: none"> a. High voltage - check voltage supply against heater voltage requirements. b. Dirty motor - clean motor housing. c. If motor has oil ports, put several drops of SAE 20 wt. non-detergent oil in each oil hole.
6. Heater blowing cold air with pilot light burning.	<ul style="list-style-type: none"> * Main burner valve not open 	<ul style="list-style-type: none"> * Open main burner valve
(1) Tighten the thermocouple nut <u>finger tight</u> and <u>snug in place</u> with appropriate wrench. DO NOT OVERTIGHTEN.		
(2) With any electrical problem, all wiring should be checked for good connections and proper voltage and repaired if a problem is found.		

Heater Component Function

Burner

Cast iron component used to channel gas and provide an area at which the fuel may ignite.

Burner Orifice

Brass metering device used to feed gas to burner at a specific rate.

Fan

Component used in conjunction with the motor to pull the hot air from heater and blow it into room for heating.

Gas Hose

Flexible connector used to convey gas from supply line in building to heater.

Motor

Electric device used to force preheated air through the heater and to circulate heat within a certain area. Converts electrical energy into mechanical energy.

Pilot Light Orifice

A metering device used to supply gas for the dual purpose of igniting the main burner and heating the thermocouple.

Pilot Safety Control Valve

A gas control valve which is held open by electrical power supplied by a pilot generator and which closes automatically to shut off the flow of gas to the main burner when the pilot flame is extinguished or becomes too small to light the main

burner.

Pilot Tube

Formed copper tube used to convey gas from the safety control valve to the pilot light orifice. The tube is internally "tinned" when natural gas is used to resist the effects of sulphur in the fuel.

Regulator

The heart of any gas supply installation. Used to deliver a working pressure to the appliance under varying conditions in tank pressure.

Thermocouple

A thermoelectric device that converts heat energy directly into electrical energy. Works in conjunction with the electromagnet in the gas control valve thereby providing gas supply for the pilot light.

Thermostat

Electrical device used as an automatic "on/off" switch which will respond to changes in temperature in a certain area. Can be wired so contacts in the thermostat open or close on temperature increase or decrease.

PARTS IDENTIFICATION
PARTS SCHEMATIC

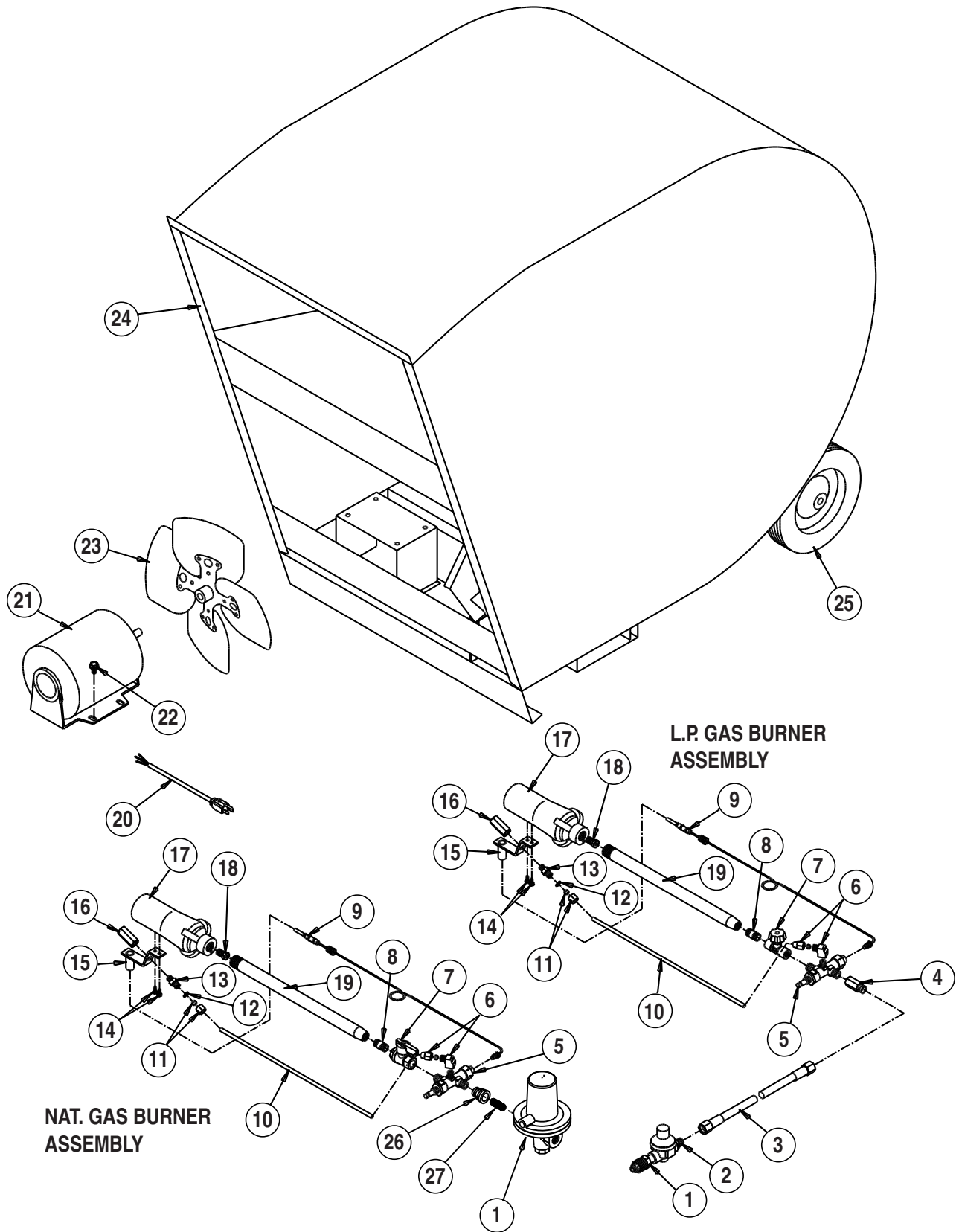

PARTS LIST

Item	Description	Model		
		334	336	
1	Regulator	L.P. Gas	21788	--
		Nat. Gas	--	01104
2	Adaptor, Hose		01098	--
3	Hose	1/4 in. x 10 ft.	22129	--
		1/2 in. x 10 ft.	--	20704*
4	Adaptor, Hose		07970	--
5	Valve, Pilot Safety		-----07966-----	
6	Ell, w/ Nut & Sleeve		-----07968-----	
7	Valve, Manual		20229	09698
8	Nipple		-----01142-----	
9	Thermocouple	30 in.	01020	--
		36 in.	--	03066
10	Pilot Tube w/ Nuts & Sleeves		-----07075-----	
11	Nut & Sleeve		-----01168-----	
12	Screen		-----01722-----	
13	Orifice, Pilot		01230	01520
14	Screws		-----01213-----	
15	Bracket, Pilot		-----03202-----	
16	Head, Pilot		-----01079-----	
17	Burner		-----01014-----	
18	Orifice, Burner		03416	01081
19	Handle		-----01018-----	
20	Cord, Power		-----04645-----	
21	Motor, 1/4 H.P.		-----07181-----	
22	Bolt		-----02747-----	
23	Fan		-----01342-----	
24	Case Assembly w/ Labels		22513	22514
25	Wheel		-----01099-----	
26	Reducer, Bell		--	23646
27	Nipple		--	01305

* Optional Accessory

Warranty Policy

EQUIPMENT

L.B. White Co., Inc. warrants that the component parts of its heater are free from defects in material and workmanship, when properly installed, operated, and maintained in accordance with the Owner's Manual safety guides and labels contained with each unit. If, **within 12 months from the date of purchase by the end user**, any component is found to be defective, L.B. White Co., Inc. will at its option, repair or replace the defective part or heater, with a new part or heater, F.O.B., Onalaska, Wisconsin.

A warranty card on file at L.B. White will automatically qualify the heater and its component parts for warranty consideration. If a warranty card is not on file, a copy of the bill of sale will be required to establish warranty qualification. If neither is available, the warranty period will be 12 months from date of shipment from L. B. White.

PARTS

L.B. White Co., Inc. warrants that replacement parts purchased from the company and used on the appropriate L. B. White heater are free from defects both in material and workmanship for **12 months from the date of purchase by the end user**. Warranty is automatic if a component is found defective within 12 months of the date code marked on the part. If the defect occurs more than 12 months later than the date code but within 12 months from the date of purchase by the end user, a copy of a bill of sale will be required to establish warranty qualification.

The warranty set forth above is the exclusive warranty provided by L.B. White, and all other warranties, including any implied warranties or merchantability or fitness for a particular purpose, are expressly disclaimed. In the event any implied warranty is not hereby effectively disclaimed due to operation of law, such implied warranty is limited in

duration to the duration of the applicable warranty stated above. The remedies set forth above are the sole and exclusive remedies available hereunder. L.B. White will not be liable for any incidental or consequential damages directly or indirectly related to the sale, handling or use of the heater, and in any event L.B. White's liability in connection with the heater, including for claims based on negligence or strict liability, is limited to the purchase price.

Some states do not allow limitations on how long an implied warranty lasts, so the above limitation may not apply to you. Some states do not allow the exclusion or limitation of incidental or consequential damages, so the above limitation or exclusion may not apply to you. This warranty gives you specific legal rights, and you may also have other rights which vary from state to state.

Replacement Parts and Service

Contact your local L.B. White dealer for replacement parts and service or call the L.B. White Co., Inc. at 1-800-345-7200

for assistance. Be sure that you have your heater model number and configuration number when calling.