

OPERATOR MANUAL

Includes Safety, Service and Replacement Part Information

**Model 240
One Man Hole Digger**

**Form: GOM26010601
Version 2.0**

Do not discard this manual. Before operation, read and comprehend its contents. Keep it readily available for reference during operation or when performing any service related function. When ordering replacement parts, please supply the following information: model number, serial number and part number. For customer service assistance, telephone 800.533.0524, +507.451.5510. Our Customer Service Department telefax number is 877.344.4375 (DIGGER 5), +507.451.5511. There is no charge for customer service activities .

Internet address: <http://www.generalequip.com>.
E-Mail location: general@generalequip.com.

Copyright 2006, General Equipment Company.



620 Alexander Dr. S.W. • PO Box 334
Owatonna, Minnesota 55060
800.533.0524 • +507.451.5510
Fax +507.451.5511
Toll-Free Fax 877.344.4375 (Digger 5)
Web: www.generalequip.com
E-mail: general@generalequip.com
Can you really afford anything less?



Congratulations on your decision to purchase a General light construction product. From our humble beginnings in 1955, it has been a continuing objective of General Equipment Company to manufacture equipment that delivers uncompromising value, service life and investment return. Because of this continuous commitment for excellence, many products bearing the General name actually set the standards by which competitive products are judged.

When you purchased this product, you also gained access to a team of dedicated and knowledgeable support personnel that stand willing and ready to provide field support assistance. Our team of sales representatives and inhouse factory personnel are available to ensure that each General product delivers the intended performance, value and investment return. Our personnel can readily answer your concerns or questions regarding proper applications, service requirements and warranty related problems.

General Equipment Company places great emphasis upon not only product performance, but also on product safety. It is important to remember that this product will only be as safe as the operators which utilize it. It just makes good, common sense to take the time to read and fully understand the contents of this manual before attempting to utilize this product in service. If you ever do have any questions or concerns about this product, please feel free to contact our Customer Service Department at the telephone numbers listed below for assistance.

If there is anything that I can do to assist your efforts when utilizing this product, please do not hesitate to contact me. For assistance after normal business hours, telephone me at 507.451.9409 or 507.363.1033. If I am not immediately available, I will attempt to return your call as soon as possible.

Sincerely,

GENERAL EQUIPMENT COMPANY

Dennis Von Ruden
President

Table of Contents

DESCRIPTION	PAGE
<i>Notice to Operators</i>	3
<i>Operator Instructional Data Sheet</i>	5
<i>Safety Precautions</i>	6
PREPARATION.	6
OPERATION.	7
MAINTENANCE, REPAIR, AND STORAGE.	9
<i>Assembly</i>	10
<i>Before Starting the Engine</i>	10
FILLING THE ENGINE GASOLINE TANK.	10
FILLING THE ENGINE CRANKCASE WITH OIL.	11
<i>Digging Operation</i>	11
OPERATIONAL DISCLAIMER.	11
CALIFORNIA PROPOSITION 65 DISCLAIMER.	11
SPARK ARRESTOR DISCLAIMER.	11
INFORMATION RELATIVE TO MINIMUM COMPONENT STANDARDS FOR THE OPERATION OF THE HOLE DIGGER.	11
GENERAL TRANSPORTATION INFORMATION.	12
DETERMINATION OF POTENTIAL SUBSURFACE HAZARDS IN THE PROPOSED DIGGING LOCATION(S).	12
SET-UP FOR DIGGING.	13
STARTING THE ENGINE WITH THE AUGER CONNECTED TO THE AUGER DRIVESHAFT.	13
OPERATING THE HOLE DIGGER.	14
UNDERSTANDING KICKBACK.	15
MINIMIZING KICKBACK FROM AN OPERATIONAL STANDPOINT.	15
MINIMIZING KICKBACK FROM A DESIGN STANDPOINT.	17
OPERATING THE HOLE DIGGER CONTINUED.	18
STOPPING THE HOLE DIGGER.	20
TEMPORARY STORAGE FOR THE HOLE DIGGER WHILE ON THE JOB SITE.	20
ADDING AND REMOVING THE NONFLIGHTED AUGER EXTENSION.	21
<i>Service</i>	22
CHANGING THE HOLE DIGGER TRANSMISSION LUBRICANT.	22
ENGINE SERVICE.	24
<i>Troubleshooting</i>	24
ENGINE.	24
OPERATIONAL PROBLEMS.	24
<i>Storage</i>	25
<i>Specifications</i>	25
<i>Replacement Parts Diagrams</i>	27

Notice to Operators

IF YOU CAN NOT READ OR DO NOT FULLY UNDERSTAND THE CONTENTS OF THIS MANUAL, PLEASE CONTACT THE FACTORY FOR PROPER ASSISTANCE BEFORE ATTEMPTING TO OPERATE THIS PRODUCT.

SI TU NO PUEDES LE'ER O NO COMPRENDES EL CONTENIDO DE ESTE MANUAL FAVOR DE PONERSE EN CONTACTO CON LA. FABRICA PARA ASISTENCIA- A PROPIA ANTES DE INTENTAR PARA OPERAR ESTE PRODUCTO.

SOLLTEN SIE DIESE GEBRAUCHSANWEISUNG NICHT LESEN KOENNEN ODER ES NICHT VOLLKOMMEN VERSTEHEN, WENDEN SIE SICH BITTE AN DEN HERSTELLER FUER RICHTIGE HILFE EHE SIE VERSUCHEN DIESES PRODUKT ZU OPERIEREN.

SI VOUS NE LISEZ OU NE COMPRENDRE ENTIEREMENT LES MATIERES DE CE MANUEL, S'IL VOUS PLAIT, CONTACTEZ L'USINE POUR L'ASSISTANCE APPROPRIEE AVANT D'UTILISER LE PRODUIT.



DANGER



CAUTION

These safety alert symbols identify important safety messages in this manual. When you see these symbols, be alert to the possibility of personal injury and carefully read the message that follows.

Do not allow anyone to operate the Hole Digger without first reading this Operator Manual and becoming familiar with its operation. The manufacturer of this Hole Digger has gone to great extremes to provide the owner(s) and/or operator(s) with the finest equipment available for its intended job function of digging holes in ice and earth formations. Yet, the possibility exists that the Hole Digger can be utilized in and/or subjected to job applications not perceived and/or anticipated by the manufacturer. Such misuse and/or misapplication of the Hole Digger can lead to the possibility of serious damage, injury or even death. It is the responsibility of the owner(s) and/or operator(s) to determine that the Hole Digger is being utilized and/or operated within the scope of its intended job function. It is the responsibility of the owner(s) and/or operator(s) to establish, monitor and constantly upgrade all safety programs and/or practices utilized in and for the operation of the Hole Digger. The purpose of such programs is to provide for owner(s)' and/or operator(s)' safety. Operators must be instructed to recognize and avoid unsafe conditions associated with their work (29 CFR 1926.21 (b)(2)) and/or applicable updated revisions. It is the responsibility of the owner(s) and/or operator(s) to determine that no modifications and/or alterations have been made to the Hole Digger. Modifications and/or alterations can lead to the possibility of serious damage, injury or even death. It is the responsibility of the owner(s) and/or operator(s) to make this Operator Manual available for consultation during all phases of operation. Refer to OSHA 2207 which contains all OSHA job safety and health rules and regulations (1926 and 1910) covering construction.



CAUTION

The concept of portable, one and two man operated, hole digging equipment has been successfully utilized for over forty years as a practical solution to many types of hole digging job requirements. The basic concept is proven and well accepted within the associated marketplaces as an alternative method to manual labor and/or larger, mounted earth drilling machinery. Use of a Hole Digger requires strenuous work activity. This type of work activity can be considered to be greater in magnitude than that experienced with the use of many other types of both light construction and

lawn and garden related equipment. This type of work activity should only be attempted by operators of adequate physical size and stature, mental awareness and physical strength and condition. Each operator is required to supply a resultant force that counteracts/balances and/or resists the natural torque and kickback forces generated during the hole digging process. The body parts most noticeably affected during the digging process are the arms, hands, wrists, shoulders, lower back and legs. The hole digging process can also produce excessive stress/strain directly to the back muscles, spinal vertebrae and many other body parts. Back related pain can be a side effect of the hole digging process. An operator with a chronic back related problem or a history of back and/or other medically related problems should not attempt to utilize the Hole Digger. Use of the Hole Digger may only aggravate this and any other medically related problem. The torque and kickback forces generated and/or encountered correspond to the natural laws of physics and are inherent to the hole digging process. They can not be changed or totally eliminated with portable one and two man operated, hole digging equipment of this design. Proper operating positions and techniques, as outlined in this manual, can be successfully utilized to minimize the effects of the torque and kickback forces upon the human body. Because of the diverse type of prevailing digging conditions, operator experience levels and operator physical characteristics, no warranty, guarantee, representation and/or liability is made by the factory as to the absolute correctness or sufficiency of any operational procedure, operational position and/or technique. There is no absolute guarantee that an operator of any given experience level, physical size and/or physical condition will be immune to the possibility of and/or probable physical side effects of the normal hole digging process. The normal hole digging process includes the auger striking buried obstructions (roots, rocks, etc.) and the resulting torque and kickback forces created. Each potential operator of the Hole Digger must be made aware of and assume the operational and physical liability described and/or associated with the hole digging process when utilizing the Hole Digger. Each potential operator not willing to assume the operational and physical liability described and/or associated with the hole digging process should not operate the Hole Digger. Proper levels of operator experience, skill and common sense are essential for maximizing the safe and efficient operation of the Hole Digger.

Record the Hole Digger and engine serial numbers in the spaces provided below.

_____ **Model Number**

_____ **Serial Number**

_____ **Engine Serial Number**

_____ **Date of Purchase**

Specifications and design are subject to change without notice or obligation. All specifications are general in nature and are not intended for specific application purposes. General Equipment Company reserves the right to make changes in design, engineering or specifications and to add improvements or discontinue manufacture at any time without notice or obligation. General Equipment Company and its agents accept no responsibility for variations which may be evident in actual products, specifications, pictures and descriptions contained in this publication.

Operator Instructional Data Sheet

The following undersigned operators of the Hole Digger described and/or pertaining to this Operator Manual have received formal safety and operational information/instruction from the undersigned owner(s)/instructor(s) in accordance to OSHA 29 CFR 1926.21 (b)(2) and/or applicable updated revisions pertaining to, but not necessarily limited to the:

- 1) **READING, COMPREHENSION AND ACKNOWLEDGEMENT OF THE MATERIAL COMPRISING THE ENTIRE CONTENTS OF THE APPLICABLE OPERATOR MANUAL FOR THE HOLE DIGGER.**
- 2) **FORMALIZED OPERATOR'S SAFETY PROGRAM TO BE DEvised BY THE OWNER OF THE HOLE DIGGER IN CONJUNCTION WITH THE CONTENTS OF THE APPLICABLE OPERATOR MANUAL FOR THE HOLE DIGGER.**
- 3) **OSHA RULES AND REGULATIONS RESEARCHED FOR AND/OR BY THE OWNER OF THE HOLE DIGGER AND DEEMED APPLICABLE TO THE SAFE AND PROPER USE AND/OR OPERATION OF THE THE HOLE DIGGER FOR ANY SPECIFIC JOB APPLICATION.**
- 4) **LOCAL LAWS, REGULATIONS AND CUSTOMS RESEARCHED FOR AND/OR BY THE OWNER OF THE HOLE DIGGER AND DEEMED APPLICABLE TO THE SAFE AND PROPER USE AND/OR OPERATION OF THE HOLE DIGGER FOR ANY SPECIFIC JOB APPLICATION.**
- 5) **FORMALIZED MAINTENANCE PROGRAM FOR THE HOLE DIGGER TO BE DEvised BY THE OWNER OF THE HOLE DIGGER IN ACCORDANCE WITH, BUT NOT NECESSARILY LIMITED TO, THE SPECIFICATIONS, GUIDELINES AND OPERATIONAL INFORMATION CONTAINED IN THE APPLICABLE OPERATOR MANUAL.**
- 6) **COMPREHENSIVE OPERATIONAL INSTRUCTIONS FOR THE CORRECT AND PROPER USE OF THE HOLE DIGGER AS PER THE CONTENTS OF THE APPLICABLE OPERATOR MANUAL.**

_____ Operator	_____ Owner/Instructor	_____ Date
_____ Operator	_____ Owner/Instructor	_____ Date
_____ Operator	_____ Owner/Instructor	_____ Date
_____ Operator	_____ Owner/Instructor	_____ Date
_____ Operator	_____ Owner/Instructor	_____ Date
_____ Operator	_____ Owner/Instructor	_____ Date

NOTE: INSERT COPIES OF THIS PAGE WITHIN THE OPERATOR MANUAL IF SPACE FOR ADDITIONAL OPERATORS IS REQUIRED.

Safety Precautions



DANGER

THE FOLLOWING SAFETY PRECAUTIONS PROVIDE SOME COMMON SENSE GUIDES TO PROMOTE SAFETY AND EFFICIENCY WITH THE 200 SERIES HOLE DIGGERS. NO WARRANTY, GUARANTEE OR REPRESENTATION IS MADE BY THE MANUFACTURER AS TO THE ABSOLUTE CORRECTNESS OR SUFFICIENCY OF ANY INFORMATION OR STATEMENT. THESE SAFETY PRECAUTIONS ARE INTENDED TO DEAL PRINCIPALLY WITH COMMON PRACTICES AND CONDITIONS ENCOUNTERED IN THE USE OF THE HOLE DIGGER AND ARE NOT INTENDED TO BE ALL INCLUSIVE. PROPER LEVELS OF OPERATOR EXPERIENCE, SKILL AND COMMON SENSE ARE ESSENTIAL FOR SAFE AND EFFICIENT OPERATION.



DANGER

THE ENGINE EXHAUST FROM THIS PRODUCT CONTAINS CHEMICALS KNOWN TO THE STATE OF CALIFORNIA TO CAUSE CANCER, BIRTH DEFECTS OR OTHER REPRODUCTIVE HARM. THIS STATEMENT IS MADE IN COMPLIANCE TO CALIFORNIA PROPOSITION 65.



DANGER

INCORRECT USE OF THE HOLE DIGGER CAN RESULT IN PROPERTY DAMAGE, PERSONAL INJURY OR EVEN DEATH. TO REDUCE THIS POSSIBILITY, GIVE COMPLETE AND UNDIVIDED ATTENTION TO THE JOB AT HAND AND FOLLOW THESE SAFETY PRECAUTIONS:

PREPARATION.

1) The 200 Series Hole Diggers are a specialized type of powered equipment, designed for a specific job function and requires adequate and thorough instruction BEFORE it is operated. The size, power, complexity and operating characteristics of this type of powered equipment would dictate that each operator must receive adequate, professional instruction regarding the proper operation of this Hole Digger before being allowed to utilize it. BEFORE attempting to utilize this Hole Digger, read this Operator Manual, view the applicable Safety and Operational Information Video and the material supplied by the engine manufacturer to familiarize each operator with its

correct operating procedures. Avoid the urge not to take the necessary time to read this Operator Manual before operating the Hole Digger. DO NOT OPERATE THE HOLE DIGGER UNTIL EACH OPERATOR COMPLETELY COMPREHENDS THE CONTENTS OF THIS MANUAL, THE APPLICABLE SAFETY AND OPERATIONAL INFORMATION VIDEO, APPLICABLE SUPPLEMENTAL INFORMATION AND THE INFORMATION SUPPLIED BY THE ENGINE MANUFACTURER.

2) Develop a comprehensive program for the safe operation of the Hole Digger by its owner(s) and/or operator(s). Such a program will include, but is not limited to: instructional requirements for operation, applicable OSHA requirements, local laws and regulations, job site safety and a Hole Digger maintenance program. Constantly examine and upgrade this program to guarantee owner(s) and/or operator(s) safety. Each operator must be fully instructed regarding the specifics of this safety program.

3) Determine that the Hole Digger is in its original, factory configuration and has not been modified in any manner. Many modifications can result in potentially dangerous configurations that can lead to property damage and/or personal injury. If there are any questions about possible modifications made to the Hole Digger, contact the Customer Service Department for specific information BEFORE utilization. There is no charge for this service.

4) Minors should never be allowed to operate the Hole Digger. Bystanders, especially children and animals, should not be allowed in the area where the Hole Digger is in use. The hole digging process can result in flying particles being emitted at high velocity and striking the operator and/or onlookers. This can lead to the possibility of property damage and/or personal injury. Keep all body parts, loose clothing, foreign objects and onlookers clear of the rotating auger and/or auger extensions.

5) Operators must be in proper physical condition, mental health and not under the influence of any substance (drugs, alcohol, etc.) which might impair vision, dexterity or judgment. Working with the Hole Digger is strenuous. If you have any condition that might be aggravated by strenuous work, check with your doctor BEFORE operating the Hole Digger. Guard against the possibility of back related injuries. Always lift the Hole Digger with leg muscles and not with the back. Operators must be of adequate height so that for any given operating configuration, the operator handle(s) remain below their shoulder sockets. Do not operate the Hole Digger if this condition is not satisfied. The 200 Series Hole Diggers require that the operator be of proper height, weight and strength to maximize

digging efficiency and minimize the possibility of personal injury.

6) Prolonged use of the Hole Digger (or other, similar machines) exposes the operator to vibrations which may produce Whitefinger Disease (Raynaud's Phenomenon). This phenomenon reduces the hand's ability to feel and regulate temperature, produces numbness and burning sensations and may cause nerve and circulation damage and tissue necrosis. Antivibration systems do not guarantee that you will not sustain Whitefinger Disease. Therefore, continuous and regular users should closely monitor the condition of their hands and fingers. After each period of use, exercise to restore normal blood circulation. If any of the symptoms appear, seek medical advice immediately.

7) Clothing must be sturdy and snug fitting, but allow complete freedom of movement. Never wear loose fitting jackets, scarves, neckties, jewelry, flared or cuffed pants or anything that could become caught on controls or moving parts. Wear long pants to protect your legs. Protect your hands with heavy duty, nonslip gloves to improve your grip. Good footing is most important when operating the Hole Digger. Wear sturdy boots with nonslip soles. Steel-toed safety shoes are highly recommended. Keep shoes properly laced. Never wear tennis shoes or other, similar type shoes which afford little or no protection. Wear an approved safety hard hat to protect the operator's head where there is a danger of head injuries. Noise, generated by the engine of the Hole Digger and the actual process itself, can damage your hearing. Wear approved sound barriers (ear plugs or ear muffs) to protect your hearing. Continuous and regular operators should have their hearing checked regularly.

8) Visually inspect the Hole Digger, auger(s), auger extension, and accessories for damaged or worn parts. Inspect each auger for the proper screw bit and blade. Look for loose and/or damaged handle grip areas. Check for loose and/or broken parts. Determine that operator controls work freely, all safety devices are operative and information/safety decals are readable. Check to determine that the Hole Digger and all related accessories are in good mechanical condition BEFORE utilization.

9) Contact appropriate representatives to determine if/where electrical cables, gas lines and other hazardous items are buried under the work surface BEFORE utilization. Some Hole Diggers feature operator handles constructed of a non metallic, composite material. Use of this material does not guarantee the operator will be properly insulated from contact with charged electrical cables. The Hole Digger and related accessories are not classified as being insulated. Contact with buried electrical cables, gas

lines and other hazardous items can result in electrocution and/or an explosion.

10) Know how the controls operate. Know how to stop the engine quickly in an emergency. Always start the engine according to the instructions as outlined in this manual to minimize the possibility of unexpected or uncontrolled auger rotation. Unexpected auger rotation can cause loss of machine control, and the possibility of property damage and/or personal injury.

11) Never exceed the recommended capacities of the Hole Digger. Refer to the **Specifications** section of this manual for more detailed information. Always utilize the correct auger and auger extension series designed for use with the Hole Digger. Some Hole Diggers can utilize specially designed augers intended for drilling holes through ice. Such an auger will find limited success when utilized to dig earth. Earth augers are not designed to drill through ice. Use of an incorrect auger or auger series can result in property damage and/or personal injury.

12) The 200 Series Hole Diggers are powered by gasoline engines which produce Carbon Monoxide fumes during the combustion process. Carbon Monoxide fumes are poisonous. Breathing Carbon Monoxide fumes while operating the Hole Digger can result in property damage and/or personal injury. The normal operation of the Hole Digger is outdoors where the potential effects of Carbon Monoxide to the operator are minimized. If the Hole Digger is operated in a closed area (indoors or outdoors), determine if supplemental ventilation is required to minimize the potential effects of Carbon Monoxide to the operator. Follow all current OSHA regulations pertaining to ventilation.

OPERATION.

1) Give complete and undivided attention to the job at hand. Do not chew gum, smoke and/or use smokeless tobacco while utilizing the Hole Digger. Do not attempt to eat and/or drink while utilizing the Hole Digger. Determine that eyeglasses and/or hearing aid devices are properly secured.

2) Gasoline is an extremely flammable fuel. Use extreme caution when handling gasoline or mixing fuel. Always utilize UL® approved containers for the storage and/or transportation of fuel. Do not smoke or bring any fire or flame near the fuel. Always shut off the engine and allow it to cool before refueling. Never remove the gasoline tank filler cap while the engine is running. Never operate an engine without a gasoline tank filler cap. Select bare ground for fueling and move at least 10 feet from the fueling spot before starting the engine.

Wipe off any spilled fuel before starting the engine and check for leakage. If a fuel or oil leak is found, do not start or run the engine until the leak is fixed and the spillage has been wiped away. Take care not to get fuel or oil on your clothing. If this happens, change your clothing immediately. Some 200 Series Hole Diggers utilize a 2 Stroke gasoline engine. Two Stroke engines require the addition of oil mixed with the gasoline for lubrication. The 240 Hole Digger utilizes a Four Stroke engine and does not require oil to be mixed with gasoline. Before operating the Hole Digger, refer to the **Specifications** section of this manual for more detailed information regarding gasoline and lubrication requirements.

3) Operate the Hole Digger with the correct number of personnel required for the specific unit. Refer to the **Specifications** section of this manual for more detailed information. Never attempt to utilize a two man Hole Digger with only one operator. One operator can not exercise adequate and safe control of the Hole Digger. Personal injury will result. Use of a one man Hole Digger by more than one operator can lead to confusion and loss of control, resulting in damage and/or personal injury. Use of a two man Hole Digger by more than two operators can lead to confusion and loss of control, resulting in damage and/or personal injury. If it is felt that a greater number of operators is required to furnish additional "down pressure" to the auger, STOP and contact the Customer Service Department for specific operational and service/maintenance information. There is no charge for this service.

4) Do not operate the Hole Digger with onlookers close by. Caution all onlookers to stand clear. Keep all body parts, loose clothing and foreign objects clear of the rotating auger. Do not utilize a shovel and/or foreign object to remove the loose soil from a hole area while the Hole Digger is in use. Such a practice can cause the shovel and/or foreign object to become entrapped by the rotating auger, leading to the possibility of property damage and/or personal injury. Replacing Pengo® type auger teeth requires that they be installed with a hammer. Use only a soft type hammer to install these types of teeth. Guard against the possibility of injuries: wear safety glasses and appropriate safety clothing. Caution all onlookers about the possibility of flying debris.

5) Start the Hole Digger by utilizing proper procedures. The 240 Hole Digger is designed for the engine to be started by the operator s left hand only. The operator s right hand controls the twist grip throttle and engine speed. Reversing the process by starting the engine

with the right hand will position the hot engine muffler in close proximity to the operator s body. This is not an approved configuration because it can result in injury from the hot muffler and/or breathing Carbon Monoxide fumes during operation. If you have any questions regarding proper starting procedures, contact the Customer Service Department BEFORE utilization. There is no charge for this service.

6) Start and operate the Hole Digger only in a well ventilated, outdoor area. Operate the Hole Digger only when/where visibility and light are adequate for the job at hand. Work carefully. Always hold the Hole Digger firmly with both hands. Wrap your fingers around the handle grips/gripping areas, keeping the grips/gripping areas cradled between your thumbs and forefingers. Always make sure the operator handle and grips/gripping areas are in good condition and free of moisture, pitch, oil or grease. Wear gloves to improve your grip. Never leave the Hole Digger running unattended.

7) Stop the engine between each hole to minimize the potential of personal injury. Special care must be exercised in slippery conditions and in difficult, overgrown terrain. Watch for hidden obstacles such as tree stumps, roots and ditches to avoid stumbling. Keep proper footing and balance at all times. The normal use of the Hole Digger is on level ground. Other digging terrains can be dangerous and should be avoided. Only properly trained operators should attempt these techniques.

8) Contact with a hot engine muffler can cause property damage and/or personal injury. Remain clear of a hot, engine muffler at all times. Do not overspeed the engine by altering the governor setting or by disconnecting the engine governor (if so equipped). Serious damage to the engine and/or personal injury can result.

9) Because this Hole Digger is classified as a low cost, hand held, low horsepower, portable type machine, it is limited in the number of practical and/or suitable job applications for this type of equipment. A particular job site, actual soil conditions, job specifications and operator experience/skill/common sense may dictate that a different type of machine (with characteristics of higher purchase cost, being mounted to a carrier vehicle, with greater horsepower and less mobility), method and/or process be utilized to properly complete the job with the degree of efficiency and safety required. Contact the Customer Service Department for specific information regarding suitable job applications, job sites, soil conditions and operator

experience/skill/common sense recommendations for this Hole Digger BEFORE utilization. There is no charge for this service.

MAINTENANCE REPAIR AND STORAGE.

1) Use only genuine, approved replacement parts for maintenance and repair. Use of parts manufactured by others can result in property damage and/or personal injury.

2) Follow the **Service** instructions as outlined in the appropriate section of the Operator Manual.

3) Always stop the engine and disconnect the spark plug wire BEFORE checking or working on the Hole Digger.

4) Always properly maintain the Hole Digger. Frequently check all fasteners and individual parts. Built in safety features are effective only if they are maintained in good working condition. Determine that the engine throttle control/throttle cable assembly is not damaged and allows for complete freedom of movement. Do not operate the Hole Digger with a damaged engine throttle control/throttle cable assembly. Determine that the centrifugal clutch assembly is not damaged, modified or worn past its useful service life. Replace any questionable part or assembly with a genuine, approved replacement part. Do not forego proper maintenance for the price of a few replacement parts. Proper maintenance does not cost--it actually pays dividends. Do not attempt any maintenance or repair work not described in the Operator Manual. Have such work performed at your dealer's servicing shop.

5) Replace the auger teeth/blade and screw bit when signs of excessive wear are seen. When such parts are not replaced at proper intervals, undue wear will occur at the boring head and auger flighting. The end result is an inverted cone configuration for the auger, which usually requires complete replacement. FIGURE 1. Digging with equipment that is past its useful service life and/or has not been properly maintained can cause property damage and/or personal injury. Auger service life can be greatly extended with constant auger wear part maintenance.

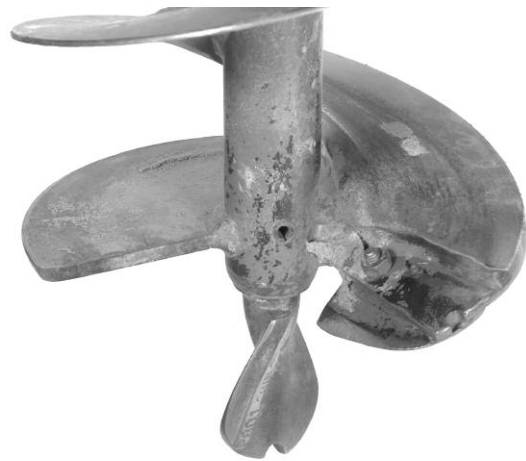

FIGURE 1

6) Utilize only the factory supplied auger pin for connecting the auger and auger extension to the Hole Digger. Use of any other connecting device, including cap screws, bolts, pins, etc., can result in damage to the Hole Digger driveshaft and/or auger drive hub. Improper connecting devices can cause property damage and/or personal injury.

7) A worn or damaged engine muffler is a fire hazard and may cause loss of hearing. Check to see that the muffler is in good condition. If the muffler is equipped with a spark arresting device, determine that it is in proper working condition at regular service intervals. Replace the spark arresting device with an approved replacement if there is any question of its integrity. It is the responsibility of the owner(s) and/or operator(s) to provide for and properly maintain a USDA approved, spark arresting muffler in an area where specified by law. Check with appropriate governing agencies for more specific information. The Hole Digger must not be operated if the muffler is faulty or has been removed. Contact with a hot muffler can cause property damage and/or personal injury. Remain clear of a hot engine muffler.

8) Consult the material supplied by the engine manufacturer for specific information relative to proper engine oil and gasoline recommendations for the engine utilized on the Hole Digger.

9) Consult the material supplied by the engine manufacturer for specific information relative to long term storage of the engine utilized on the Hole Digger.

Assembly

Open the shipping carton immediately upon receipt. Visually inspect the contents of the carton for freight damage and/or missing parts. If shipping damage is evident, contact the delivering carrier immediately to arrange for an inspection of the damage by their claims representative. Federal law requires that a claim be filed within a specified time period. If missing parts are detected, notify your dealer who will assist you in obtaining them.

Included in the shipment should be the following:

- 1 each, engine/handle/transmission assembly.
- 1 each, bottle of engine oil.
- 1 each, bag containing the Operator Manual and other publications.

The Hole Digger is shipped from the factory completely assembled. The transmission is lubricated at the factory and will not require further servicing prior to the initial usage. Visually inspect the throttle control, throttle cable assembly and the carburetor for signs of damage. Rotate the throttle control to determine that the spring mechanism allows the throttle lever of the carburetor to travel from its low speed to the high speed and back position without any restriction and/or binding.

DANGER

DETERMINE THAT ALL COMPONENTS OF THE ENGINE THROTTLE CONTROL ASSEMBLY ALLOW FOR PROPER FUNCTION. THE THROTTLE LEVER OF THE CARBURETOR MUST RETURN THE ENGINE TO THE IDLE SPEED AS STATED IN THE SPECIFICATION SECTION OF THIS MANUAL WHEN THE TWIST GRIP THROTTLE IS RELEASED BY THE OPERATOR. IF THIS DOES NOT OCCUR, CONTACT YOUR DEALER OR THE CUSTOMER SERVICE DEPARTMENT FOR SPECIFIC INFORMATION RELATIVE TO CORRECTING THIS OCCURANCE. DO NOT OPERATE THE HOLE DIGGER UNTIL THIS OCCURANCE HAS BEEN CORRECTED. AN IMPROPERLY FUNCTIONING THROTTLE CONTROL CAN RESULT IN PROPERTY DAMAGE AND/OR PERSONAL INJURY.

Check all fasteners for security. Consult a fastener torque chart for the proper torque value if any fastener is found to require retorquing.

Before Starting the Engine

FILLING THE ENGINE GASOLINE TANK.

Tools Required:

- 1 each, small, clean funnel.

CAUTION

The 240 Hole Digger utilizes an all-position, Four Stroke, gasoline engine. While this engine may have the same physical appearance of a conventional Two Stroke engine, the lubrication systems are completely different. The Subaru EH035 engine does not require oil to be mixed with gasoline. The crankcase oil does not function as a reservoir for an oil injection system.

- 1) Carefully clean the filler cap and surrounding area to insure that no dirt or debris falls into the gasoline tank.
- 2) Fill the fuel tank with fresh, clean, unleaded automotive gasoline. Leaded "regular" grade gasoline is an acceptable substitute. **DO NOT USE GASOLINE CONTAINING METHANOL (WOOD ALCOHOL).** Gasoline containing a maximum of 10 per cent ethanol or grain alcohol (sometimes referred to as Gasohol) may be used but requires special care when the engine is stored for extended periods.
- 3) Use of a properly blended gasoline for operation during the intended season will result in easier engine starting. Do not use gasoline left over from the previous season of operation.
- 4) Never fill the fuel tank completely full. Instead, fill the fuel tank to within 1/4 to 1/2 inch of the top of the tank to provide space for fuel expansion. Always wipe any fuel spillage from the engine and the Hole Digger before starting the engine.

DANGER

DO NOT SMOKE NEAR THE GASOLINE TANK. DO NOT FILL THE GASOLINE TANK WITH THE ENGINE RUNNING OR IF IT IS HOT. ALLOW AMPLE TIME BETWEEN EACH REFUELING FOR THE ENGINE TO COOL.

FILLING THE ENGINE CRANKCASE WITH OIL.

Tools Required:

1 each, small, clean funnel with a flexible extension spout.

Filling the engine crankcase with oil will require a level working platform of sufficient size and appropriate height. As alternative, the transmission driveshaft can be securely mounted in a suitable bench vice.

- 1) Wipe any dust or dirt from the crankcase dipstick/filler plug area. Remove the dipstick/filler plug.
- 2) Using the funnel, add oil to the engine crankcase. For proper classifications and/or amount, consult the material supplied by the engine manufacturer for specific information.
- 3) Replace the dipstick/filler plug and tighten. Wipe off any excess spilled oil. Properly dispose of the spilled oil.
- 4) Consult the material supplied by the engine manufacturer for other service related information including oil change interval.



CAUTION

Do not operate the Hole Digger unless proper oil level is maintained. Improper oil level can result in property damage and/or personal injury. Consult the material supplied by the engine manufacturer for information relative to proper maintenance procedures.

Digging Operation

OPERATIONAL DISCLAIMER.

THE MANUFACTURER OF THIS HOLE DIGGER MAKES NO WARRANTY OR GUARANTEE THAT IT IS MERCHANTABLE AND/OR SUITABLE FOR ANY SPECIFIC JOB APPLICATION AND THAT IT WILL HAVE THE POWER REQUIRED TO DIG A SPECIFIC DIAMETER HOLE DOWN TO A SPECIFIC DEPTH IN A SPECIFIC SOIL CLASSIFICATION.

CALIFORNIA PROPOSITION 65 DISCLAIMER.



DANGER

THE ENGINE EXHAUST AND DUSTS/BY-PRODUCTS FROM THE OPERATIONAL PROCESS OF THIS PRODUCT CONTAINS CHEMICALS KNOWN TO THE STATE OF CALIFORNIA TO CAUSE CANCER, BIRTH DEFECTS, OR OTHER REPRODUCTIVE HARM.

SPARK ARRESTOR DISCLAIMER.



DANGER

DO NOT OPERATE THE HOLE DIGGER ON ANY FOREST COVERED, BRUSH COVERED OR GRASS COVERED, UNIMPROVED LAND UNLESS AN APPROVED SPARK ARRESTOR IS INSTALLED ON THE MUFFLER. THE SPARK ARRESTOR MUST BE MAINTAINED IN PROPER WORKING ORDER BY THE OWNER AND/OR OPERATOR. IN THE STATE OF CALIFORNIA, THE ABOVE IS REQUIRED BY LAW. OTHER STATES MAY HAVE SIMILAR LAWS. FEDERAL LAWS WILL APPLY ON FEDERAL LANDS.

INFORMATION RELATIVE TO MINIMUM COMPONENT STANDARDS FOR THE OPERATION OF THE HOLE DIGGER.

For operational safety and overall productivity considerations, it is required that specific Hole Digger components meet minimum acceptable operational standards BEFORE utilization:

- 1) Operator handle be properly mounted to the transmission and be of proper structural integrity. If cracking or deformation is detected, replace the operator handle with a factory approved replacement part only.
- 2) The twist grip throttle control be equipped with a properly fitting handle grip of sufficient integrity to allow for proper job function as outlined within this manual. A loose fitting grip or a grip without a full end cap is not permitted.
- 3) Throttle cable is in proper mechanical condition that allows it to perform its intended job function as outlined within this manual. A cable with bends, abrasions or other damage that restricts or limits inner wire movement must be replaced with a factory approved replacement part only.

4) Throttle control is installed in the correct operating position and be in a mechanical condition that allows it to perform its intended job function as outlined within this manual. A worn or damaged throttle control hand grip or any other, internal part must be replaced with a factory approved replacement part only. Do not operate the Hole Digger with the cover plate not properly installed or missing. Do not allow foreign material to accumulate within the throttle control assembly. Clean all throttle control components and repair as necessary according to a regular maintenance schedule.

5) An engine ON/OFF ignition switch that allows it to perform its intended job function as outlined within this manual. Replace any damaged engine ON/OFF ignition switch with a factory approved replacement part only.

6) Centrifugal clutch assembly in proper mechanical condition that allows it to perform its intended job function as outlined within this manual. Replace any centrifugal clutch assembly with operational characteristics that do not allow it to properly disengage at the specific engine idle speed or properly slip during overload conditions.

7) Each auger is in a structural condition that allows it to perform its intended job function as outlined within this manual. Bent auger axles should not exceed established limits. Bent axles exceeding established limits should be properly discarded.

8) Each auger has replaceable wear parts (screw bit and blade) that allows it to perform its intended job function as outlined within this manual. An auger with a screw bit and/or blade worn past normal service life limits is not to be utilized under any circumstances.

DANGER

OPERATION OF A HOLE DIGGER UTILIZING COMPONENTS NOT MEETING MINIMUM OPERATIONAL STANDARDS CAN RESULT IN PROPERTY DAMAGE AND/OR PERSONAL INJURY.

GENERAL TRANSPORTATION INFORMATION.

When transporting the Hole Digger in/on a motor vehicle, the gasoline tank breather vent (if so equipped) must be completely closed to eliminate the accidental seepage of fuel and resulting potential fire

hazard. In order to minimize the possibility of damage to the Hole Digger, always transport it to the job site with the auger disconnected. All equipment must be secured in/on vehicles with suitable strapping or tie downs. Personnel should not be transported in the same compartment as equipment and fuel supplies. Consult applicable OSHA regulations for specific information.

CAUTION

An improperly secured Hole Digger and related accessories can fall from a moving vehicle and result in property damage and/or personal injury.

DETERMINATION OF POTENTIAL SUBSURFACE HAZARDS IN THE PROPOSED DIGGING LOCATION(S).

DANGER

BEFORE ATTEMPTING TO DIG WITH THE HOLE DIGGER, DETERMINE THE POTENTIAL SUBSURFACE HAZARDS WHICH MAY EXIST IN THE PROPOSED DIGGING LOCATIONS(S). POTENTIAL SUBSURFACE HAZARDS MAY INCLUDE, BUT NOT BE LIMITED TO, THE FOLLOWING:

- 1) ROCKS OF ANY SPECIFIC SIZE.
- 2) DIFFERENCES AND/OR VARIANCES IN SPECIFIC SOIL CLASSIFICATIONS.
- 3) ROOTS OF ANY SPECIFIC SIZE.
- 4) BURIED MATERIALS SUCH AS GARBAGE AND OTHER DEBRIS.
- 5) BURIED PRESSURIZED PIPELINES CONTAINING SUCH MATERIALS AS NATURAL GAS, PROPANE, ETC.
- 6) BURIED ELECTRICAL CABLES.

DANGER

BEFORE ATTEMPTING TO DIG WITH THE HOLE DIGGER IN THE PROPOSED LOCATION(S), CONTACT ALL APPROPRIATE AGENCIES TO DETERMINE THE EXACT LOCATION(S) OF ALL BURIED PIPELINES, POWER LINES AND MATERIAL DEBRIS. MANY UTILITIES AND OTHER AGENCIES WILL PERFORM THIS TASK FOR A MINIMAL COST OR AT NO COST. HAVE ALL SUBSURFACE HAZARDS MARKED FOR EASY

RECOGNITION. DIRECT CONTACT WITH THESE AND OTHER SUBSURFACE HAZARDS CAN RESULT IN PROPERTY DAMAGE AND/OR PERSONAL INJURY.

SET UP FOR DIGGING.

1) The Hole Digger is designed for one operator to transport it by the operator handle to, while on, and from the job site. Connect the auger to the Hole Digger with the correct, factory-supplied auger pin. All 200 Series Hole Diggers utilize the 3/8 inch (9.5 mm) diameter pin, PN 2121 Auger Pin.

CAUTION

The auger pin supplied with the Hole Digger is designed to withstand the high stress encountered while digging. Use of any other connecting device, including cap screws, bolts, pins, etc., can result in damage to the Hole Digger driveshaft and/or auger drive hub. Improper connecting devices can cause property damage and/or personal injury.

DANGER

DO NOT CONNECT THE AUGER TO THE HOLE DIGGER WITH THE ENGINE RUNNING. A SUDDEN CHANGE IN THE ENGINE SPEED WILL RESULT IN HOLE DIGGER DAMAGE AND/OR PERSONAL INJURY.

DANGER

THE 240 HOLE DIGGER IS DESIGNED FOR ONE MAN OPERATION. USE BY MORE THAN ONE OPERATOR WILL LEAD TO CONFUSION AND LOSS OF CONTROL, RESULTING IN HOLE DIGGER DAMAGE AND/OR PERSONAL INJURY. THE CONTROLS ARE DESIGNED FOR THE OPERATOR TO CHOKE AND START THE ENGINE WITH HIS LEFT HAND WHILE OPERATING THE THROTTLE CONTROL WITH HIS RIGHT HAND. WITH THIS INTENDED OPERATING POSITION, THE ENGINE EXHAUST MUFFLER WILL FACE OPPOSITE THAT OF THE OPERATOR. THE RESULTING FUMES AND HEAT WILL BE DIRECTED AWAY FROM THE OPERATOR. DO NOT OPERATE THE HOLE DIGGER WITH THE ENGINE EXHAUST MUFFLER/SHIELD FACING TOWARD THE OPERATOR. THIS OPERATION POSITION WILL ALLOW THE OPERATOR TO COME IN

CONTACT WITH THE HOT SURFACE OF THE ENGINE MUFFLER/SHIELD AND RESULT IN PROPERTY DAMAGE AND/OR PERSONAL INJURY. IT WILL ALSO ALLOW THE OPERATOR TO INHALE HIGH LEVELS OF CARBON MONOXIDE THAT CAN RESULT IN PERSONAL INJURY.

STARTING THE ENGINE WITH THE AUGER CONNECTED TO THE AUGER DRIVESHAFT.

1) Grass and other overgrowth conditions will hamper the digging characteristics of any earth auger by becoming "clogged" around the auger blade and screw bit. Removal of such obstructions from the hole location will increase digging efficiency and overall productivity.

2) Place the Hole Digger on the desired hole location. The engine throttle is intended to be controlled by the operator's right hand. The engine is intended to be started by the operator's left hand. Do not operate the Hole Digger with the engine throttle control being controlled by the operator's left hand. The operator should position himself on firm footing. FIGURE 2.



FIGURE 2

3) Turn the engine ON/OFF ignition switch to the ON position. The switch is located near the underside of the engine carburetor. FIGURE 3.



FIGURE 3

4) Depress the engine primer system bulb 7 to 10 times to help feed fuel directly into the carburetor. FIGURE 4.



FIGURE 4

5) If the engine is cold or the ambient temperature is low, move the choke control lever to the left/closed position (away from the fuel tank) to deploy the engine choke mechanism. A warm (previously run) engine may not require choking. FIGURE 5.

6) Using the right hand, rotate the engine throttle control to the one half open position. This procedure is to be followed regardless of the ambient temperature.

7) Using the left hand, pull the engine starter handle slowly, until resistance is felt. This is the compression point. Return the starter handle to its original position and pull swiftly. Do not pull the rope out to its maximum, extended length. Repeat as necessary for the engine to start. Allow the starter handle to retract slowly. If the engine does not start after five pulls, stop



FIGURE 5

and consult the material supplied by the engine manufacturer.

8) Allow the engine to properly "warm up" and operate without the requirement for engine choke. As the engine warms up, move the choke lever up to the right/open position (toward the fuel tank). In cold weather, initial starting will require more pulls because an extremely rich fuel/air mixture is required. Check for proper centrifugal clutch operation, excessive transmission noise and/or vibration.

9) Stopping the Hole Digger is accomplished by releasing the twist grip throttle control to its maximum, closed (engine idle speed) position and then turning the engine ON/OFF ignition switch to the OFF position. The switch is located near the underside of the engine carburetor.

CAUTION

If the Hole Digger and/or an individual component/accessory does not appear to be functioning properly, STOP and do not further operate the Hole Digger until the corrective action has been completed. If there are any questions regarding the proper operation of the Hole Digger, contact the dealer or the Customer Service Department for assistance BEFORE further utilization. There is no charge for this service.

OPERATING THE HOLE DIGGER.

1) Do not attempt to begin digging with the Hole Digger until the operator is ready to begin the process and is in full control of the machine.

2) Rotate the twist grip throttle control counterclockwise to increase the engine speed. The

auger will begin to rotate when the engine speed reaches the centrifugal clutch initial engagement speed.

3) Normal operating procedure for the Hole digger is to dig with the engine operating at full speed. This will allow the centrifugal clutch to become more firmly engaged. This procedure will transmit more usable power to the auger, resulting in greater productivity and less component wear.



CAUTION

When digging in areas filled with known buried obstructions such as tree roots, rocks and other debris, operate the Hole Digger at less than full (an intermediate) speed to insure a more rapid release of the centrifugal clutch when an obstruction is encountered. This is an industry wide operating procedure.

4) The Hole Digger is equipped with a centrifugal clutch assembly within the transmission, designed to slip whenever overloaded or if the auger comes in contact with a buried obstruction. Newton's Laws of Physics allow the centrifugal clutch assembly to ALWAYS slip whenever overloaded or if the auger comes in direct contact with a buried obstruction. The term slippage is not intended to infer that the centrifugal clutch assembly becomes fully disengaged with no horsepower and torque is being transmitted to the auger. In the slipping mode, a centrifugal clutch still transmits a specific amount of horsepower and torque to the auger. This specific amount of horsepower and torque directly proportional to many factors including: the mechanical condition of the centrifugal clutch assembly and the rotational speed of the centrifugal clutch assembly when the initial slippage occurs. The response time for the centrifugal clutch assembly to react to an overload condition is directly proportional to its rotational speed. The higher the rotational speed (RPM) of the centrifugal clutch at the time of overload, the greater amount of time it requires to react and actually slip. This phenomenon is inherent with all centrifugal clutch assemblies. It is also inherent with all powered equipment incorporating such a device.



DANGER

STRIKING BURIED OBSTRUCTIONS SUCH AS TREE ROOTS, ROCKS AND OTHER DEBRIS AT ANY SPECIFIC ENGINE OPERATING SPEED CAN

CAUSE THE HOLE DIGGER TO TRANSMIT REACTIONARY TYPE "IMPACT" LOADS TO THE OPERATOR. THESE TYPES OF LOADS ARE CHARACTERIZED BY A SHARP, PULSATING MOVEMENT OF THE HOLE DIGGER IN A COUNTERCLOCKWISE DIRECTION (AS VIEWED BY THE OPERATOR). SUCH LOADS CAN LEAD TO THE LOSS OF OPERATOR CONTROL AND RESULT IN PERSONAL INJURY. THE OPERATIONAL EFFECTS ARE ALIKE TO THAT OF UTILIZING A COMMON ELECTRIC DRILL AND OTHER, ROTATION TYPE, POWERED EQUIPMENT. THE RELATED PHENOMENON IS INHERENT WITH ALL SUCH TYPES OF ROTATION TYPE, POWERED EQUIPMENT AND IS TERMED AS KICKBACK.

UNDERSTANDING KICKBACK.

The operation of the Hole Digger involves engine torque being transmitted and multiplied by the transmission to the auger. The energy is then used to dig holes. But to every force (action), there is always a reaction force in the opposite direction. Thus, if the auger contacts a buried obstruction, the operator will feel the left side of the handle of the Hole Digger being "thrust" toward him. This "thrusting" force experienced by the operator is called kickback. The speed that the handle moves (and magnitude of the resulting impact force) is directly proportional to the amount/speed of the kickback force experienced by the operator. The torque and kickback generated by the digging process is inherent with a portable, one man Hole Digger of this type. The operational effects are alike to that of utilizing a common, electric drill and other, rotation type, powered tools.

MINIMIZING KICKBACK FROM AN OPERATIONAL STANDPOINT.

The operator should keep the left side of the handle as close to his body (left hip and leg areas) as possible to minimize machine "kickback" when a buried obstruction is encountered by the auger. Assume operating positions that allow exercising reactive "body english" against the torque sensation created by the digging process. Keep upper arms as close to the upper body as possible to maximize mechanical leverage. An operator should position his back as vertical as possible by bending the legs as required during the digging process. Positioning the left foot ahead of the right foot at a comfortable distance will enhance proper body position. Maintaining proper operating position is one of the most IMPORTANT and EFFECTIVE procedures for controlling kickback. Improper operating positions only aggravate the effects

of kickback upon the operator. FIGURE 6 depicts a proper operator position. FIGURE 7 depicts an improper operator position.



FIGURE 6

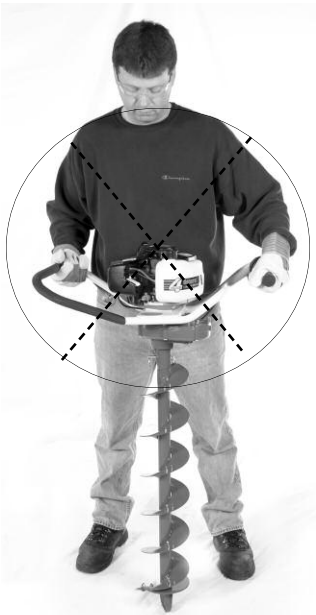

FIGURE 7

Keep a firm, but steady, grip on the operator handle. Wrap your fingers around the handle and handle grip areas, keeping them cradled between the thumbs and forefingers. REMEMBER- PROPER OPERATOR POSITIONS ENHANCE THE CONTROL OF THE HOLE DIGGER, REDUCE OPERATOR FATIGUE, AND INCREASE OVERALL PRODUCTIVITY.

CAUTION

Always make sure the operator handle and throttle control handle grip areas are in good condition and free of moisture, pitch, oil or grease. Wear gloves to improve your grip. Bent and damaged handles, a throttle control with a damaged/no grip or handles without the gripping area material (PVC coating) aggravate the effects of kickback upon the operator by limiting control and comfort. Do not operate the Hole Digger until such damage has been repaired and/or replaced.

CAUTION

Always assume that any digging site can include some form of buried obstruction. Always be prepared for unexpected auger contact with buried tree roots, rocks, etc. Under certain operating conditions, striking a buried obstruction can produce a severe and/or sudden kickback force to the hip and/or leg areas. It is possible that this kickback force can have the magnitude to "throw" the operator from the Hole Digger. The operator must maintain physical and mental alertness and be prepared to accommodate this phenomenon. Failure to properly accommodate this phenomenon can result in property damage and/or personal injury.

DANGER

IF, DURING THE HOLE DIGGING PROCESS THE OPERATOR LOOSES FULL CONTROL OF THE HOLE DIGGER FOR ANY REASON THE FOLLOWING PROCEDURE IS SUGGESTED:

AS A GENERAL RULE, AS SOON AS THE OPERATOR REALIZES THAT HE IS IN THE PROCESS OF LOOSING FULL CONTROL OF THE HOLE DIGGER, HE SHOULD "PUSH" HIMSELF FREE AND CLEAR FROM THE OPERATOR HANDLE. THE PROCEDURE REQUIRES THE OPERATOR TO FULLY COMPREHEND THAT HE IS LOOSING CONTROL OF THE HOLE DIGGER AND TO REACT ACCORDINGLY WITH APPROPRIATE BODY MOVEMENT. IMPROPER REACTIONS TO THIS PHENOMENON CAN RESULT IN PROPERTY DAMAGE AND/OR PERSONAL INJURY.

A HOLE DIGGER WITH AN IMPROPERLY MAINTAINED ENGINE THROTTLE CONTROL WILL "SPIN" ABOUT ITS AXIS WHEN THE OPERATOR LOOSES PARTIAL AND/OR FULL CONTROL. IN THE EVENT OF THIS OCCURRENCE, DO NOT ATTEMPT TO STOP THE ENGINE BY GRASPING THE ROTATING OPERATOR HANDLE. DO NOT INTRODUCE ANY FOREIGN OBJECT IN AN ATTEMPT TO STOP AND/OR BLOCK THE ROTATING HANDLE. INSTEAD, ALLOW THE ENGINE TO EXHAUST ITS FUEL SUPPLY. DETERMINE THAT ALL COMPONENTS OF THE ENGINE THROTTLE CONTROL ASSEMBLY ALLOW FOR PROPER FUNCTION BEFORE ATTEMPTING TO FURTHER UTILIZE THE HOLE DIGGER.

MINIMIZING KICKBACK FROM A DESIGN STANDPOINT.

1) The 240 Hole Digger features the widest operator handle of any machine in its class. The handle is biomechanically positioned to enhance control by allowing the operator to exert "body english" against the torque and kickback generated by the digging process.

2) The Hole Digger utilizes an antivibration material (PVC coating) that is applied to the operator handle during the manufacturing process. This material is intended to enhance control and help dampen the torque and kickback experienced by the operator during the digging process.

3) The Hole Digger utilizes a twist grip throttle control. This type of throttle control device was selected over other configurations (for the operator handle configuration utilized and specific digging power) because it allows the operator to wrap his thumb around the forefinger and effectively maximize the strength in his right hand. This design feature affords the operator greater control of the machine when counteracting the effects of torque and kickback during the digging process.

4) The Hole Digger is designed to utilize the General Equipment Company PN 2121 Auger Pin to retain the earth auger to the transmission driveshaft. This pin is not intended to shear and absorb kickback related forces when the earth auger comes in sudden contact with a buried object. The pins are utilized for the following reasons:

a) Such an occurrence (pin shear) would result in extensive physical damage to the driveshaft and auger drive hub.

b) Even if the physical damage to the Hole Digger could be eliminated and/or minimized from the actual process, it could require an unknown (and potentially large) number of auger pins to complete the digging process for any specific hole.

c) Even if the cost of replacement auger pins is not a factor, the resulting productivity produced by the actual process would not be deemed acceptable by industry and/or social standards for the Hole Digger.

d) Given the infinite number of soil conditions which could be encountered during the actual process, it is impossible to design and supply a specific auger pin to shear at a specific torque value which would produce acceptable operational results for the Hole Digger.

e) Given the infinite number of potential operators and their methods utilized during the actual process, it is impossible to design and supply a specific auger pin to shear at a specific torque value which would produce acceptable operational results for the Hole Digger.

f) Given the infinite number of combinations of soil conditions, auger diameters, auger boring head conditions, digging depths, mechanical operating conditions, operators and operator methods encountered during the actual process, it is impossible to design and supply a specific auger pin to shear at a specific torque value which would produce acceptable operational results for the Hole Digger.

6) For comparison purposes, it is interesting to note that portable electric drills do not utilize any torque limiting or clutch device to allow the drill bit to slip at any specific torque value for drilling purposes. As with a Hole Digger, such a device would make the drill a useless tool because of the infinite number of potential operating configurations and the inability to design specific components to meet the requirements of each operating configuration.

7) Many portable electric screwdrivers incorporate a torque limiting or clutch device which allows the operator to preset the torque output of the tool to a specific value. This is especially useful and desirable when hardware can be secured to specific torque values according to industry published standards.

8) Portable electric drills and screwdrivers are two separate tools designed for different and specific job applications. The drilling process has different requirements than the fastening process offered by screwdrivers. The operational characteristics of portable electric screwdrivers can not be confused

and/or substituted for the operational characteristics of the Hole Digger.

OPERATING THE HOLE DIGGER CONTINUED.

5) Auger boring heads are designed for digging in a wide variety of soil types and/or conditions. Each boring head design represents a compromise in overall digging efficiency, productivity and service life for any given soil condition. As a general rule, pressing down on the operator handle is not required to initiate and/or sustain the digging process. In most soils of moderate Proctor Densities, augers will dig at rates that will not cause the centrifugal clutch to overload and slip. In most soft soils of low Proctor Densities (sandy, etc.), it may be necessary to hold up on the operator handle to reduce the digging rate of the auger. The natural tendency of any auger design, in low Proctor Density soil conditions, is to dig at a rate which causes the centrifugal clutch to overload and slip. In most hard soils of high Proctor Densities (hard clay, etc.), it may be necessary to press down on the operator handle to establish and maintain acceptable digging rates. Proper digging procedure for any given soil condition is the accumulation of actual experience, skill and common sense. For any given soil condition, allow the auger to dig at the rate most comfortable to the operator, yet not causing the centrifugal clutch to overload and slip.

CAUTION

An improper operating procedure can allow the auger to "bind" and/or "bury" itself in the hole. This is usually the result of allowing the auger to feed at an excessive rate. This phenomenon is also characteristic of digging with smaller (2 to 4 inch) diameter augers. In this operating condition, the Hole Digger is not capable of transmitting ample power to "free" the auger. Do not continue to overload and slip the centrifugal clutch assembly.

CAUTION

Damage to property and/or personal injury can result if the operator loses partial and/or full control of the Hole Digger while in this configuration. STOP the Hole Digger and remove it from the buried auger. The buried auger can then be retrieved by various, industry accepted methods. Contact the Customer Service Department for specific information. There is no charge for this service.

6) Some soil conditions may require more power to dig the hole than the Hole Digger is capable of delivering for a given auger diameter. This problem is more noticeable in areas of semiconsolidated soils or compacted soils having high Proctor Densities. Examples of such soil types include: soft shale, hard pan and caliche. The power required to dig a hole is directly proportional to the soil resistance encountered by the auger and the square of the auger diameter. For example: an 8 inch diameter auger requires almost 2 times the power than that of a 6 inch diameter, given identical soil conditions. This problem is best minimized by the addition of suitable down force by the operator and by utilizing augers equipped with new, replacement screw bits and teeth. The manufacturer makes no guarantee that the Hole Digger is capable of digging a hole of specific diameter in any given soil condition. Contact the Customer Service Department for information relative to your specific requirements. There is no charge for this service.

DANGER

IT IS A MISCONCEPTION THAT A LARGER DIAMETER HOLE CAN BE OBTAINED BY FIRST DIGGING AN INITIAL HOLE WITH A SMALLER "PILOT" AUGER AND THEN UTILIZING A LARGER DIAMETER AUGER TO "REAM" THE HOLE TO THE DESIRED SIZE. THIS METHOD WILL NOT ALLOW THE AUGER SCREW BIT TO PRODUCE SUFFICIENT DIRECTIONAL STABILITY FOR THE LARGER DIAMETER AUGER DURING THE "REAMING" PROCESS. THIS METHOD WILL RESULT IN PROPERTY DAMAGE, LOSS OF OPERATOR CONTROL AND/OR PERSONAL INJURY.

7) When digging in areas filled with tree roots, small rocks or other, buried obstructions, allow the auger blade to "chip away" at the obstruction until the auger can pass by (by working the object loose) or go through it (as in the case of penetrating tree roots). This technique usually involves holding up on the operator handle and establishing a minimal feed rate for the auger. Proper operator position will minimize the effects of kickback being generated by the auger blade contacting the object. As with any hole digging procedure, the mechanics of this technique require the accumulation of actual experience and common sense to maximize its effectiveness. Many times the size and nature of the buried object will simply prevent the auger from passing by or going through it. Continued use of the Hole Digger will only contribute to equipment damage and/or personal injury. Instead, remove the

buried object with a shovel or other suitable tool and proceed to dig the hole with the Hole Digger to the desired depth.



CAUTION

Some job applications may encounter buried obstructions on the job site that are too large in size to allow the usage of a machine such as and/or with the operating limitations of the Hole Digger. Utilization of the Hole Digger on these job sites can cause property damage and/or personal injury. Exercise proper common sense by selecting the proper size and/or type of equipment for the intended job application.

8) To minimize the amount of loose soil that remains at the bottom of the hole, stop the rotation before retracting the auger. In most soil conditions, the auger will retract with less effort if allowed to rotate at a slow speed. This procedure, however, will leave more loose soil at the bottom of the hole. Proper procedures for obtaining the cleanest, most usable hole for any soil condition requires the accumulation of actual experience and common sense.

9) The twist grip throttle controls the digging process by regulating the engine speed. Keep a firm grip on it at all times. As with any safety device, it requires constant and proper maintenance to function as intended.

10) Attempting to restart the Hole Digger's engine with the auger in a partially or completely dug hole requires extra caution. In this configuration, the throttle control can be advanced beyond the idle speed position before the operator can exercise proper control of the Hole Digger. The more accepted procedure (when not utilizing the nonflighted auger extension) is to first remove the unit from the hole and restart the engine according to the described method. Return the unit to the hole with the engine running at idle speed (the auger should not be rotating) and proceed to dig the hole to the desired depth.



CAUTION

Restarting the engine with the auger in a partially or completely dug hole requires a higher degree of operator experience, skill and common sense over that of an introductory or novice level of expertise. The manufacturer is aware that many operators elect to restart the Hole Digger's engine with the

auger in a partially or completely dug hole on a regular basis while in the field. The manufacturer also realizes that this procedure must be utilized when the nonflighted auger extension is utilized to extend the digging depth. The manufacturer has no control over the experience, skill and common sense levels of each operator of the Hole Digger. The manufacturer has no control over each job site or specific job application for the Hole Digger.

Individual operator experience, skill, common sense, job site location and specific job application must affect the final decision on specific operating procedures for the Hole Digger. Each operator must decide if he possesses adequate/proper experience, skill and common sense for operating the Hole Digger for any given and/or specific job application.

11) Both the auger blade and screw bit must be replaced when signs of excessive wear are visible. A regularly scheduled maintenance program will increase the service life of the auger and increase overall productivity by substantially reducing operator fatigue. An auger requiring replacement of the blade and screw bit is depicted in FIGURE 8.



CAUTION

Do not utilize an auger with the blade and screw bit worn past their specific service limits. Excessive wear to the blade and screw bit will allow the auger flighting to wear in a tapered or inverted cone configuration. The work boring head may actually be only capable of digging a hole 60 to 75 percent of the nominal diameter of the auger. This configuration will allow the auger flighting to "bind" within the hole and substantially reduce operator control and productivity.

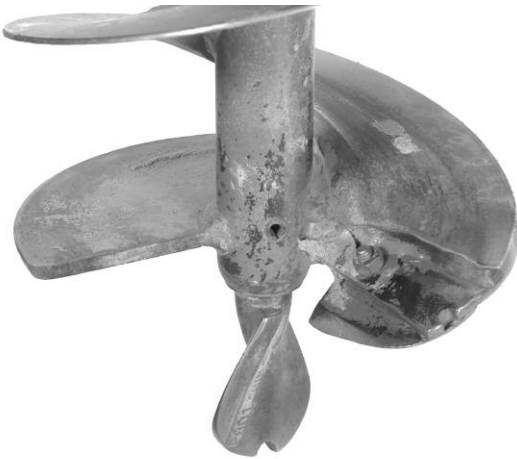

FIGURE 8

12) Avoid placing serious stress to the back and lower body members. Always lift in a straight line with your legs. Maintain the back in a vertical position as much as allowed by the digging process. Proper wrist position during the digging process can minimize and/or reduce stress and strain related damage potential to this body area. Operator control can be enhanced and fatigue reduced by attempting to keep wrists as perpendicular to the operator handle as feasible during the digging process. FIGURE 9.



FIGURE 9

13) Stop the engine between each hole to minimize the possibility of personal injury. Special care must be exercised in slippery conditions and in difficult, overgrown terrain. Store the Hole Digger on the job site by digging a shallow hole or by disconnecting it from the auger and/or nonflighted auger extension. Close the gasoline tank breather vent (if so equipped) when the Hole Digger is not in use.

STOPPING THE HOLE DIGGER.

Stopping the Hole Digger is accomplished by rotating the twist grip throttle control to its maximum, closed position and allowing the engine to return to its idle speed. Turn the engine ON/OFF ignition switch to the OFF position. With the throttle control functioning properly, the engine can be brought to idle speed and the auger rotation stopped when the throttle control lever is fully closed or suddenly released. If this is not occurring, check the throttle control, throttle cable, carburetor lever, and engine idle speed for binding and/or proper adjustment.

TEMPORARY STORAGE FOR THE HOLE DIGGER WHILE ON THE JOB SITE.

The Hole Digger can be temporarily stored on the job site by one of three acceptable methods. The chosen method is to be determined by the operator based upon personal preference and/or job site conditions:

- a) Digging a shallow hole and leaving the Hole Digger connected to the auger.
- b) Disconnecting the Hole Digger from the auger and/or auger extension and storing it in a level configuration. FIGURE 10.



FIGURE 10

- c) Storing the Hole Digger while connected only to a lead auger with the engine spark plug facing upward. This configuration minimizes the potential for the hot muffler and/or muffler heat shield area igniting grass or other combustible materials. FIGURE 11.

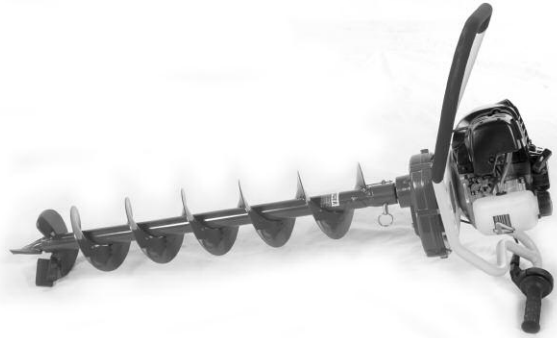

FIGURE 11

ADDING AND REMOVING THE NONFLIGHTED AUGER EXTENSION.

Many digging jobs require a hole deeper than that provided by standard length augers. For many such requirements, a nonflighted auger extension is available. The nonflighted auger extension extends the digging depth by an additional 15 inches (381 mm).

CAUTION

Utilization of the nonflighted auger extension requires additional operator experience, skill and common sense over that of an introductory or novice level of expertise. The manufacturer has no control over the experience, skill and common sense levels of each operator of the Hole Digger. Utilization of the nonflighted auger extension requires the accumulation of actual hole digging experience, skill and common sense. Each operator must decide if his experience, skill and common sense level is sufficient to allow him to proceed with the utilization of the nonflighted auger extension for any given and/or specific job application.

Follow this accepted procedure for utilizing the nonflighted auger extension to extend the digging depth:

- 1) Dig to the approximate full depth of the auger utilizing the described operating instructions. Remove as much loose soil from the hole as possible utilizing the described operating instructions.
- 2) STOP the engine and remove the auger from the hole. Disconnect the spark plug wire to prevent accidental engine starting. Close the gasoline tank breather vent (if so equipped).

- 3) Disconnect and remove the Hole Digger from the

auger. Place the auger in the hole. Attach the auger extension to the auger and secure with an auger pin. The Hole Digger can now be connected to the auger extension and secured with an auger pin. Reconnect the spark plug wire.

- 4) Follow the instructions outlined for starting and operating the Hole Digger. Use extra caution when starting the Hole Digger's engine with the auger in the hole. Proceed to dig to the desired depth or to the full depth of the auger extension.

DANGER

NEVER UTILIZE MORE THAN ONE NONFLIGHTED AUGER EXTENSION TO INCREASE THE DIGGING DEPTH OF THE AUGER. THIS EXTENSION IS NOT EQUIPPED WITH AUGER FLIGHTING TO ELEVATE THE LOOSE BORINGS FROM THE HOLE. CONSEQUENTLY, MULTIPLE USE OF NONFLIGHTED AUGER EXTENSIONS WILL ALLOW THE AUGER TO "BURY" ITSELF IN THE HOLE. SUCH USE CAN LEAD TO THE LOSS OF OPERATOR CONTROL AND/OR PERSONAL INJURY.

After the desired digging depth has been achieved, the nonflighted auger extension is removed by utilizing this accepted procedure:

- 1) Remove as much loose soil from the hole as possible with the auger rotating at an intermediate speed. STOP the engine and disconnect the spark plug wire to prevent accidental engine starting. Close the gasoline tank breather vent (if so equipped).

- 2) Lift the auger extension and the Hole Digger up far enough out of the hole so that the auger extension is clear. Block the remaining auger with an auger fork to prevent it from falling back into the hole. Disconnect the Hole Digger from the auger extension. Remove the auger extension and auger from the hole. FIGURE 12.



FIGURE 12

3) Reconnect the engine spark plug wire.



DANGER

THE PROCEDURE OUTLINED FOR THE USE OF THE NONFLIGHTED AUGER EXTENSION OFFERS THE MOST ADAPTABLE METHOD OF EXTENDING THE DIGGING DEPTH FOR THE WIDEST CROSS SECTION OF PROBABLE OPERATORS. THIS PROCEDURE TAKES INTO ACCOUNT ANTICIPATED OPERATOR EXPERIENCE, SKILL AND COMMON SENSE. THE MANUFACTURER IS AWARE THAT NOT ALL OPERATORS WILL ELECT TO FOLLOW THIS PROCEDURE. THE MANUFACTURER HAS NO CONTROL OVER INDIVIDUAL OPERATION PROCEDURES AND/OR DECISIONS. MANY OPERATORS MAY ELECT TO UTILIZE THE NONFLIGHTED AUGER EXTENSION CONNECTED DIRECTLY TO THE AUGER AND BYPASS THE LONGER, MORE TIME CONSUMING PROCEDURE OUTLINED ABOVE. INDIVIDUAL OPERATORS MAY ELECT TO CHOOSE OTHER PROCEDURES IN AN EFFORT TO REDUCE THE ASSOCIATED PRODUCTION COSTS. THE RESULTING MACHINE CONFIGURATIONS CAN PLACE THE HANDLE ALMOST LEVEL WITH (OR EVEN ABOVE) THE SHOULDERS OF THE OPERATOR. AT THIS HEIGHT LEVEL, THE HOLE DIGGER IS DIFFICULT TO CONTROL AGAINST POSSIBLE KICKBACK FORCES. THIS IS NOT A MANUFACTURER APPROVED PROCEDURE BECAUSE IT REQUIRES EACH POTENTIAL OPERATOR TO HAVE EXCEPTIONAL HEIGHT AND

EXPERT WORK EXPERIENCE, SKILL AND COMMON SENSE. UNFORTUNATELY, THERE IS STILL NO REAL ASSURANCE THAT EACH AND EVERY OPERATOR WITH EXCEPTIONAL HEIGHT AND EXPERIENCE, SKILL AND COMMON SENSE CAN ALWAYS EXERCISE ADEQUATE CONTROL OF THE HOLE DIGGER TO GUARANTEE PERSONAL SAFETY. PERSONAL SAFETY CAN NEVER BE GUARANTEED FOR ANY GIVEN AND/OR SPECIFIC JOB APPLICATION FOR ANY TYPE OF POWERED EQUIPMENT. THE ACCEPTED PROCEDURE, AS OUTLINED IN THIS OPERATOR'S MANUAL, IS STRONGLY RECOMMENDED. THE MANUFACTURER CAN NOT CONDONE AND/OR APPROVE ANY OTHER PROCEDURE.

Service

CHANGING THE HOLE DIGGER TRANSMISSION LUBRICANT.

Tools Required:

- 1 each, 7/16 inch wrench
- 1 each, #2 Phillips head screwdriver
- 1 each, torque wrench, 120 inch pounds (13.5 N.m.) capacity with 7/16 inch socket
- 1 each, rubber hammer

Parts Required:

- 1 each, PN 240-0100 gasket.
- 1 each, PN 210-0720 grease product or 8 ounces (224g) of high temperature transmission or marine-grade, wheel bearing grease classified for extreme pressure (EP) applications. Fisk Brothers (Lubriplate brand) GR132 is an approved lubricant.

The 240 Hole Digger utilizes a fully enclosed, double reduction transmission for multiplying and transmitting engine torque to the auger. The principle involves engine horsepower and torque being transmitted through a centrifugal clutch and two sets of gear reductions into a final driveshaft. Grease is provided for lubrication and heat dissipation for the bearings, gears and clutch assembly.

A pressure relief valve, PN 5677, is located on the top surface of the transmission cover to relieve any excess pressure created in the transmission due to heat rise. Should this valve become plugged, the following problems can occur:

a) Lubrication grease can be forced out between the rings and the final driveshaft.

b) The gasket that separates the two halves of the transmission can push out, causing a loss of lubrication grease.

The potential for these problems can be minimized by cleaning the pressure relief valve at regular intervals with an approved safety solvent. The transmission is shipped from the factory filled with approximately 8 ounces (224g) of high temperature lubricant. This lubricant contains an extreme pressure additive which is designed to cling to the gear teeth at high rotational speeds.

1) Change the transmission lubricant every 50 hours of operation, or more often as necessary, if the Hole Digger is operated in extremely dusty or dirty conditions.

2) Drain the gasoline from the fuel tank into a UL® approved container. Wipe any excess spilled gasoline and dispose of properly.

3) Position the Hole Digger on a suitable work bench with the operator handle level with the ground. As an alternative, the transmission driveshaft can be securely mounted in a suitable bench vice. Wipe any dust or dirt from the area where the transmission separates.



DANGER

GASOLINE IS AN EXTREMELY FLAMMABLE FUEL. USE EXTREME CAUTION WHEN HANDLING GASOLINE. DO NOT SMOKE OR BRING FIRE OR FLAME NEAR THE FUEL.

4) Loosen and remove the six capscrews that fasten the transmission together. Using the rubber hammer, split and separate the transmission cover and case. Exercise caution not to damage the dowel pins. If the bearing journals of the secondary pinion, PN 210-0310, are difficult to remove from the ball bearings, remove the PN 37040200 Screw from both bearing housings. Insert a 1/4-20 UNC capscrew into the housing. Using the wrench, rotate the capscrew to thrust against the pinion bearing journal until it clears the pinion gear support bearing. Repeat the process with the remaining pinion gear bearing journal if necessary. FIGURE 13. Remove the PN 210-0100 gasket. Remove the primary gear and pinion assembly, PN 210-0340 and PN 210-0310.



FIGURE 13

5) Clean the interior surfaces of the transmission cover and case with an approved safety solvent.

6) Clean each gear with an approved safety solvent. Inspect the teeth for excess wear, cracks or fatigue. Replace each component as necessary.



CAUTION

Observe all applicable safety precautions for the solvent. Dispose of the used transmission lubricant according to all applicable laws and regulations.

6) If necessary, reinstall PN 37040200 Screw into the bearing housings. Properly secure with the provided hardware.

7) Fill the transmission cover and case with 8 ounces (224g) of high temperature transmission grease containing an extreme pressure additive. Part Number 210-0720 lubrication grease or Fisk Brothers GR-132 is an approved lubricant. FIGURE 14. If the Fisk Brothers lubricant can not be readily sourced, an acceptable alternative is a marine-grade wheel bearing grease that contains an EP (denoting extreme pressure) additive. Distribute the grease equally around all gear teeth. Do not utilize standard lithium based greases intended for common lubrication purposes. These types of grease are not formulated to operate at the higher operating temperatures encountered during the hole digging process. Such greases also do not contain an extreme pressure additive for use with gears.



FIGURE 14

7) Reinstall the primary gear and pinion assembly. Distribute the grease equally around all gear teeth. Replace the old transmission gasket with a new gasket, PN 210-0100. Align the transmission dowel pins when reinstalling the cover. Reinstall the fasteners with the hexagon nuts on the cover side of the transmission. Torque all fasteners to 96 in lbs (12 N.m.) in an "X" sequence.

8) Rotate the final driveshaft and check for excessive noise and/or binding. If excessive noise and/or binding is evident, disassemble the transmission and investigate for probable causes. Reassemble and retorqued to the specified amount. Recheck for excessive noise and/or binding.

9) Inspect the Hole Digger for loose, worn or damaged parts. Replace any questionable part or assembly with a genuine, approved replacement part. Do not attempt any maintenance or repair work not described in the Operator's Manual. Have such work performed at your dealer's servicing shop.

ENGINE SERVICE

Consult Instructions for Use Manual provided by the engine manufacturer for specific service and maintenance information regarding:

- 1) muffler
- 2) spark plug
- 3) air filter
- 4) carburetor adjustment
- 5) maintenance schedule
- 6) engine oil change
- 7) troubleshooting
- 8) short and long term storage

Keep this information stored with the Operator Manual for the Hole Digger so it will always be available for use when the engine requires service or maintenance. A properly maintained engine will add considerably to the service life and overall productivity of the Hole Digger.

Troubleshooting

ENGINE.

ENGINE FAILS TO START

Ignition switch in OFF position. Place in ON position.

Incorrect carburetor adjustment. See **Service** section.

Ignition wire to spark plug loose or disconnected. Reconnect.

Fuel supply exhausted. Refill fuel tank.

ENGINE LOOSES POWER

Incorrect carburetor adjustment. See **Service** section.

Water in fuel supply. Drain and replace fuel.

Plugged engine exhaust ports. See **Service** section.

Dirty spark plug. See **Service** section.

Incorrect throttle control/cable adjustment. See **Assembly** section.

Gasoline tank breather vent closed (if so equipped). Open vent.

Dirty air filter. See **Service** section.

ENGINE OVERHEATS

Incorrect carburetor adjustment. See **Service** section.

Incorrect fuel/oil mixture ratio. See **Before Starting The Engine** section.

Cooling fins clogged. Remove engine blower housing and clean cooling fins.

OPERATIONAL PROBLEMS.

HOLE DIGGER LACKS POWER

Incorrect amount of transmission lubricant. See **Service** section.

Centrifugal clutch assembly worn. Replace

Auger diameter too large for given soil condition. See **Digging Operation** section.

Incorrect throttle control/cable adjustment. See **Assembly** section.

AUGER ROTATES AT IDLE SPEED

Incorrect throttle control/cable adjustment does not permit proper engine idle speed. See **Assembly** section.

Centrifugal clutch worn. Replace.

Incorrect engine idle speed. See **Service** section.

Storage

Proper procedure for long term storage of the Hole Digger will protect it against the affects of corrosion and damage. If the Hole Digger is not to be operated for a period of 30 days or more, proceed to store as follows:

1) Clean all accumulated dirt and grease from the Hole Digger utilizing an approved safety solvent.



CAUTION

Observe all applicable safety precautions for the solvent

2) Follow the procedure as outlined in the material supplied by the engine manufacturer detailing long term storage of the engine.

3) Check all visible parts for wear, breakage or damage. Order any part required to make the necessary repair. This will avoid a needless delay when operating the Hole Digger at next use.

4) Apply a light coat of protective grease to the transmission final driveshaft to prevent the formation of rust.

5) Do not store the Hole Digger connected to an auger. Always store the Hole Digger with the operator handle level with the ground.

6) Store the Hole Digger inside. If the Hole Digger must be stored outside, protect it and each auger with a suitable covering.

Specifications

ENGINE.

TYPE	Subaru Robin EH035V
HIGH SPEED	9000 RPM (No Load)
IDLE SPEED	2900 RPM
SPARK PLUG GAP	.030 inch (.76 mm)
FUEL	Unleaded, automotive grade
GASOLINE TANK CAPACITY	24 US ounces (0.75 liter)

TRANSMISSION.

TYPE	Enclosed, spur geared, double reduction.
REDUCTION RATIO	42.5 to 1
LUBRICANT CAPACITY	8 US ounces (224 g)
LUBRICANT SPECIFICATION	High temperature transmission grease containing an extreme pressure (EP) additive.

CLUTCH 3 inch (76 mm) diameter, all-metal, automatic cam type centrifugal.

AUGER CAPACITY: 2 inch (51 mm) diameter up to and including 8 inch (203 mm) diameter. Refer to DIGGING OPERATION for specific information.

GENERAL.

MODEL	M240
REQUIRED NUMBER OF OPERATORS	1
LEAD AUGER SERIES TYPE/NUMBER	General® 2135
AUGER EXTENSION TYPE/SERIES NUMBER	General® 2135

Left Blank

Replacement Parts Diagrams

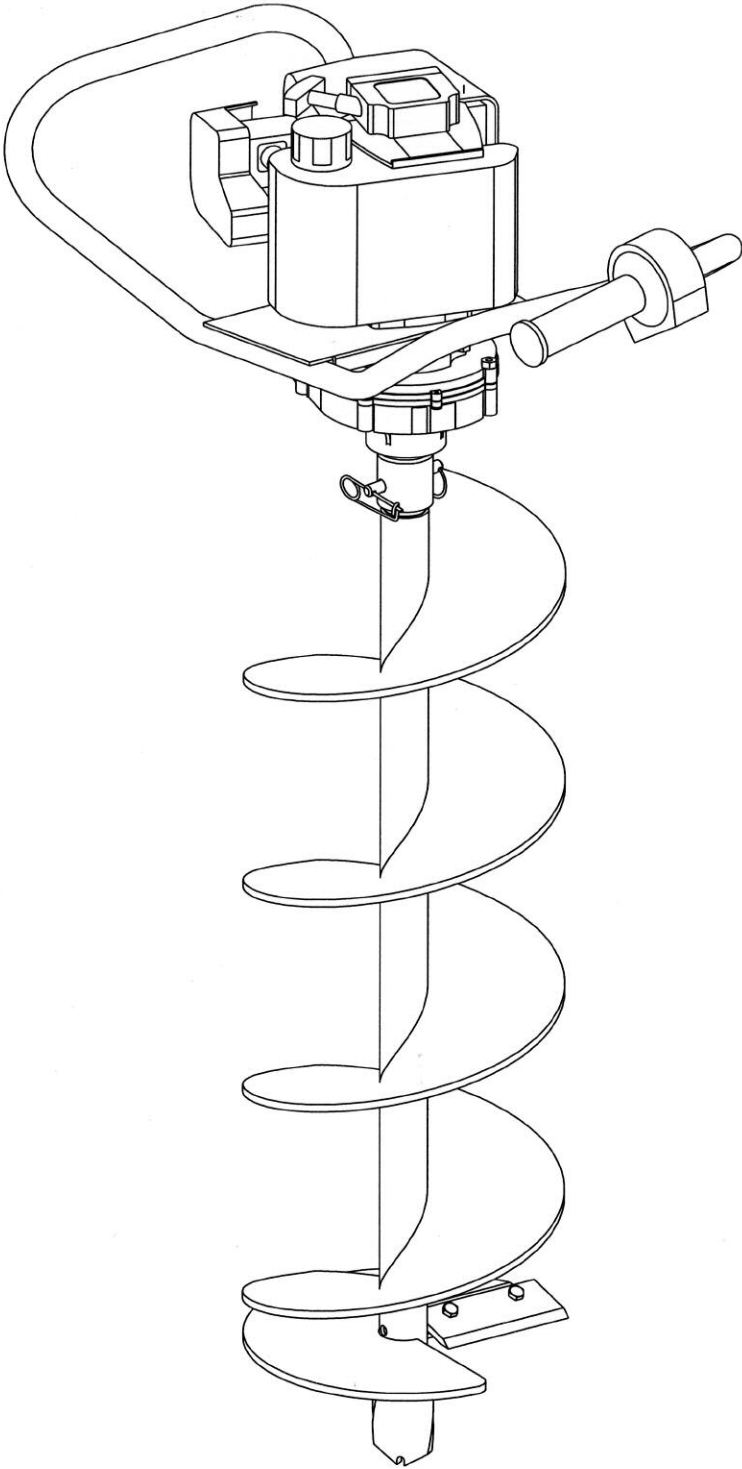

Transmission Assembly 240 Hole Digger [Serial Numbers 2550 Thru 28256]

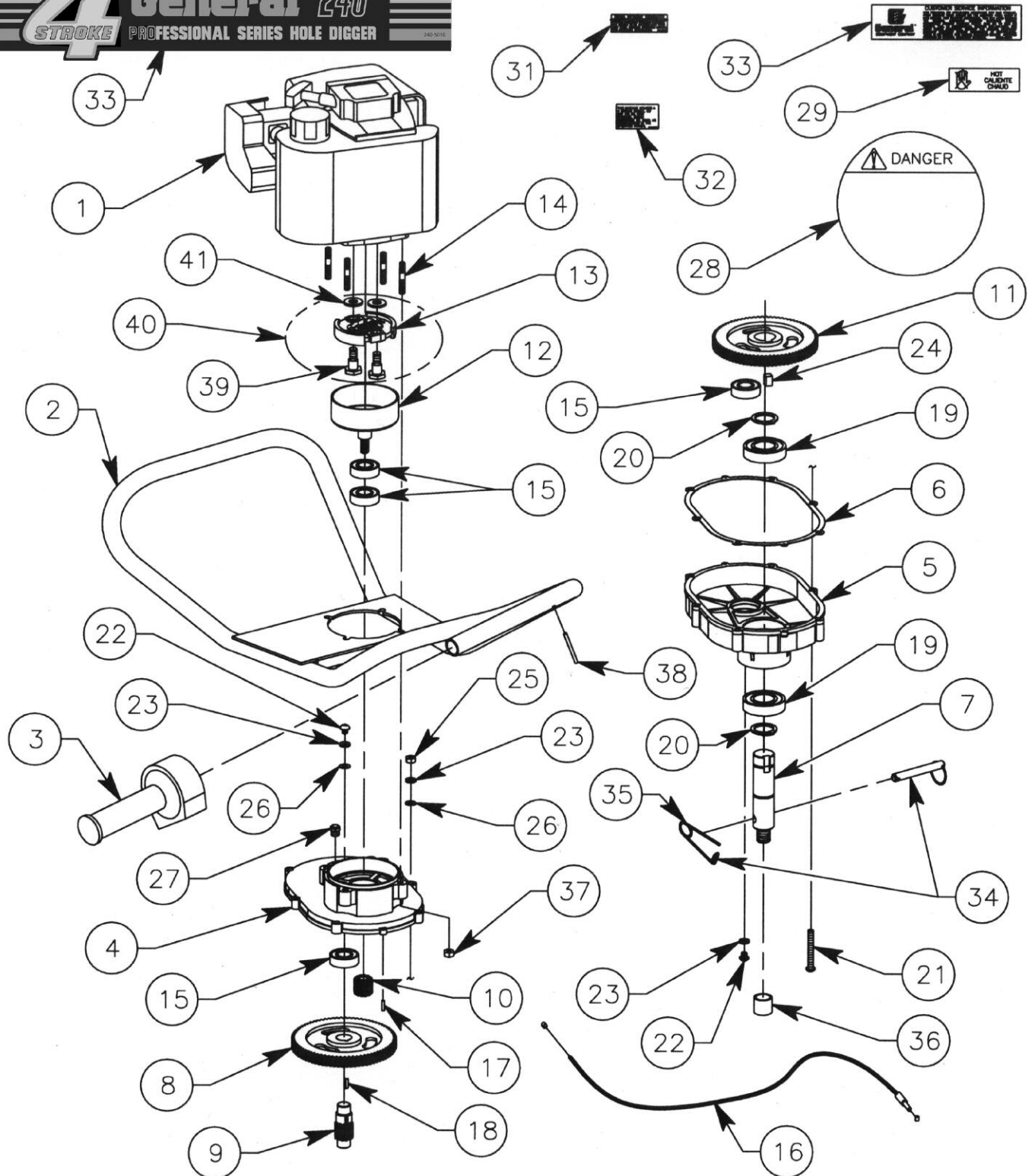

Transmission Assembly
240 Hole Digger
[Serial Numbers 2550 Thru 28256]

REFERENCE NUMBER	PART NUMBER	DESCRIPTION	QTY
1	EH035V	Engine, Robin Subaru, 1.6 HP	1
2	240-0090	Handle, Operator, Complete, Less Throttle Control	1
3	310-0030	Throttle, Twist Control, Plastic, Complete	1
4	240-0130	Cover, Transmission	1
5	240-0120	Case, Transmission	1
6	240-0100	Gasket, Transmission	1
7	210-0330	Shaft, Drive, 1" Round	1
8	240-0350	Gear, Secondary, 78 Tooth	1
9	210-0310	Gear, Pinion, Secondary	1
10	210-0320	Gear, Clutch, Primary	1
11	240-0340	Gear, Primary, 78 Tooth	1
12	240-0160	Drum, Clutch	1
13	240-0170	Rotor And Shoe Assembly, Clutch	1
14	240-0200	Stud, M6 x 1/4-28 UNF, Plated	4
15	99502H	Bearing, Sealed	4
16	240-0080	Cable, Throttle	1
17	51020400	Pin, Dowel, 1/8" x 1/2"	2
18	3	Key, Woodruff, 1/8" x 1/2", Alloy	1
19	99R16	Bearing, Sealed	2
20	5160-98	Ring, Snap	2
21	34041600	Screw, Machine, Round Head, Phillips, Plated	6
22	37040200	Screw, Panhead, Philips, 1/4-20 UNC x 5/16", Plated	2
23	16040000	Washer, Lock, 1/4" Plated	8
24	63050400	Key, Square, 5/16" x 1/2", Alloy	1
25	18040000	Nut, Hex, 1/4-20 UNC, Plated	6
26	AN-960-416L	Washer, AN Type, 1/4", Plated	8
27	5677	Valve, Pressure Release	1
28	210-5020	Decal, Danger	1
29	210-5040	Decal, Hot	1
30	SG24-5072	Decal, Assistance	1
31	240-5020	Decal, Starting	1
32	240-5030	Decal, 4 Stroke	1
33	240-5010	Decal, (Model 240)	1
34	2121	Pin, Auger, (Includes P/N AP-21-S)	1
35	AP-21-S	Pin, Safety	1
36	210-0010	Cap, Protective, Driveshaft	1
37	12040001	Nut, Hex. 1/4-28 UNF, Captivated Washer, Plated	4
38	20020900	Pin, Roll, 1/8" x 1-1/8"	1
39	240-0180	Bolt, Clutch Pivot	2
40	240-0170 KIT	Clutch Kit (Includes (1) P.N 240-0170, (2) P/N 240-0180, and (2) P/N 350-0190)	1
41	240-0190	Washer, Clutch	2
42	240-0150	Clip, Modified	2
43	48030401	Screw, Cap, Self Tap, #10-24 UNC x 1/2", Plate	2
44	210-0541	Decal, Caution	1
45	240-5080	Decal, Weight	1

Transmission Assembly 240 Hole Digger [Used Starting With Serial Numbers 28257]

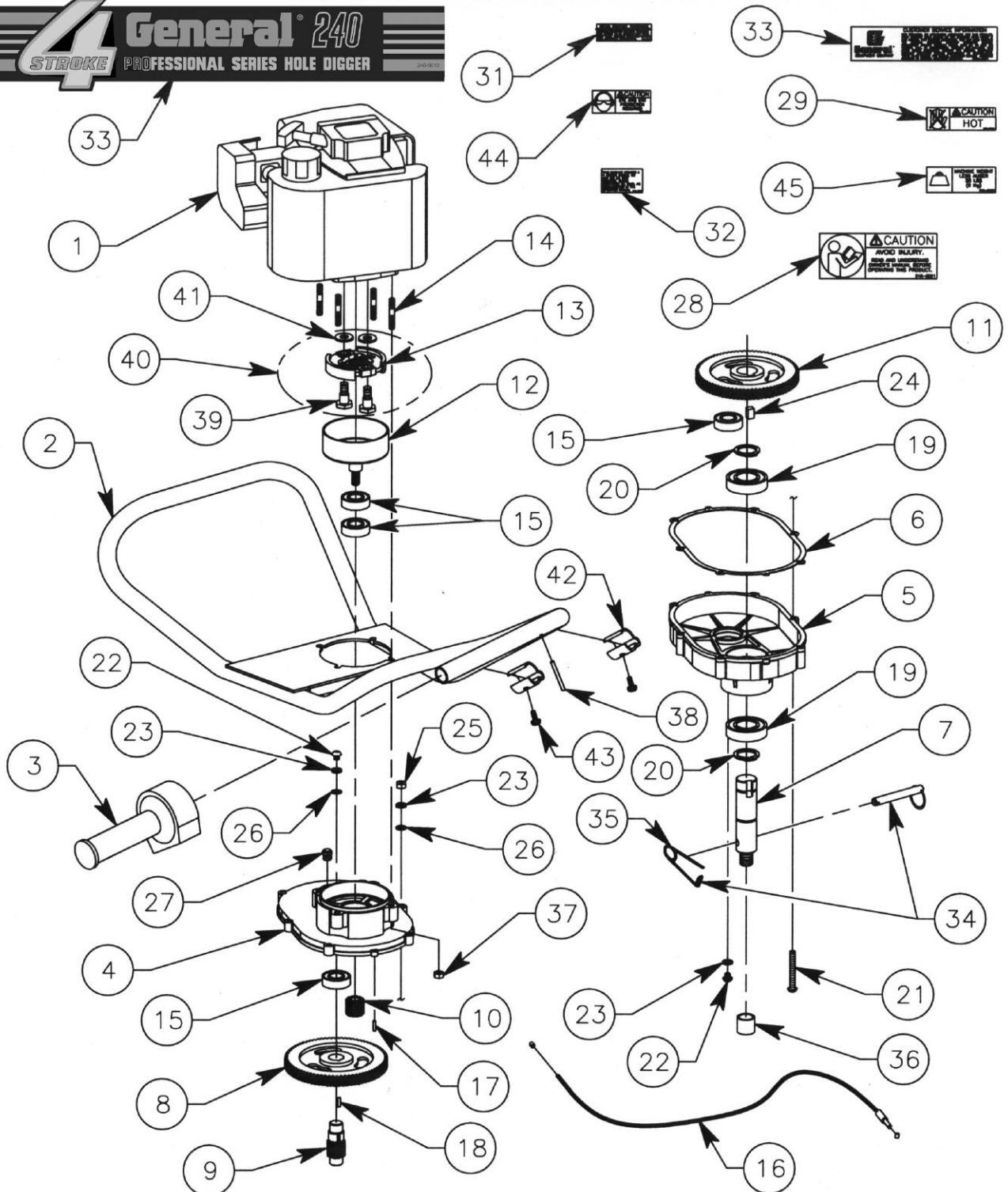

Transmission Assembly
240 Hole Digger
[Used Starting With Serial Numbers 28257]

REFERENCE NUMBER	PART NUMBER	DESCRIPTION	QTY
1	EH035V	Engine, Robin Subaru, 1.6 HP	1
2	240-0090	Handle, Operator, Complete, Less Throttle Control	1
3	310-0030	Throttle, Twist Control, Plastic, Complete	1
4	240-0130	Cover, Transmission	1
5	240-0120	Case, Transmission	1
6	240-0100	Gasket, Transmission	1
7	210-0330	Shaft, Drive, 1" Round	1
8	240-0350	Gear, Secondary, 78 Tooth	1
9	210-0310	Gear, Pinion, Secondary	1
10	210-0320	Gear, Pinion, Primary	1
11	240-0340	Gear, Primary, 78 Tooth	1
12	240-0160	Drum, Clutch	1
13	240-0170	Rotor And Shoe Assembly, Clutch	1
14	240-0200	Stud, M6 x 1/4-28 UNF, Plated	4
15	99502H	Bearing, Sealed	1
16	240-0080	Cable, Throttle	1
17	51020400	Pin, Dowel, 1/8" x 1/2"	2
18	3	Key, Woodruff, 1/8" x 1/2", Alloy	1
19	99R16	Bearing, Sealed	2
20	5160-98	Ring, Snap	2
21	34041600	Screw, Machine, Round Head, Phillips, Plated	6
22	37040200	Screw, Panhead, Philips, 1/4-20 UNC x 5/16", Plated	2
23	16040000	Washer, Lock, 1/4" Plated	8
24	63050400	Key, Square, 5/16" x 1/2", Alloy	1
25	18040000	Nut, Hex, 1/4-20 UNC, Plated	6
26	AN-960-416L	Washer, AN Type, 1/4", Plated	8
27	5677	Valve, Pressure Release	1
28	210-5021	Decal, Caution	1
29	210-5041	Decal, Caution	1
30	SG24-5072	Decal, Assistance	1
31	240-5020	Decal, Starting	1
32	240-5030	Decal, 4 Stroke	1
33	240-5010	Decal, (Model 240)	1
34	2121	Pin, Auger, (Includes P/N AP-21-S)	1
35	AP-21-S	Pin, Safety	1
36	210-0010	Cap, Protective, Driveshaft	1
37	12040001	Nut, Hex. 1/4-28 UNF, Captivated Washer, Plated	4
38	20020900	Pin, Roll, 1/8" x 1-1/8"	1
39	240-0180	Bolt, Clutch Pivot	2
40	240-0170 KIT	Clutch Kit (Includes (1) P.N 240-0170, (2) P/N 240-0180, and (2) P/N 350-0190)	1
41	240-0190	Washer, Clutch	2
42	240-0150	Clip, Modified	2
43	48030401	Screw, Cap, Self tap, #10-24 UNC x 1/2", Plated	2

Replacement Parts Diagrams 2135 Series Earth Augers

1" Diameter Round Drive Connection
For Use With 210/240 Series Hole Diggers

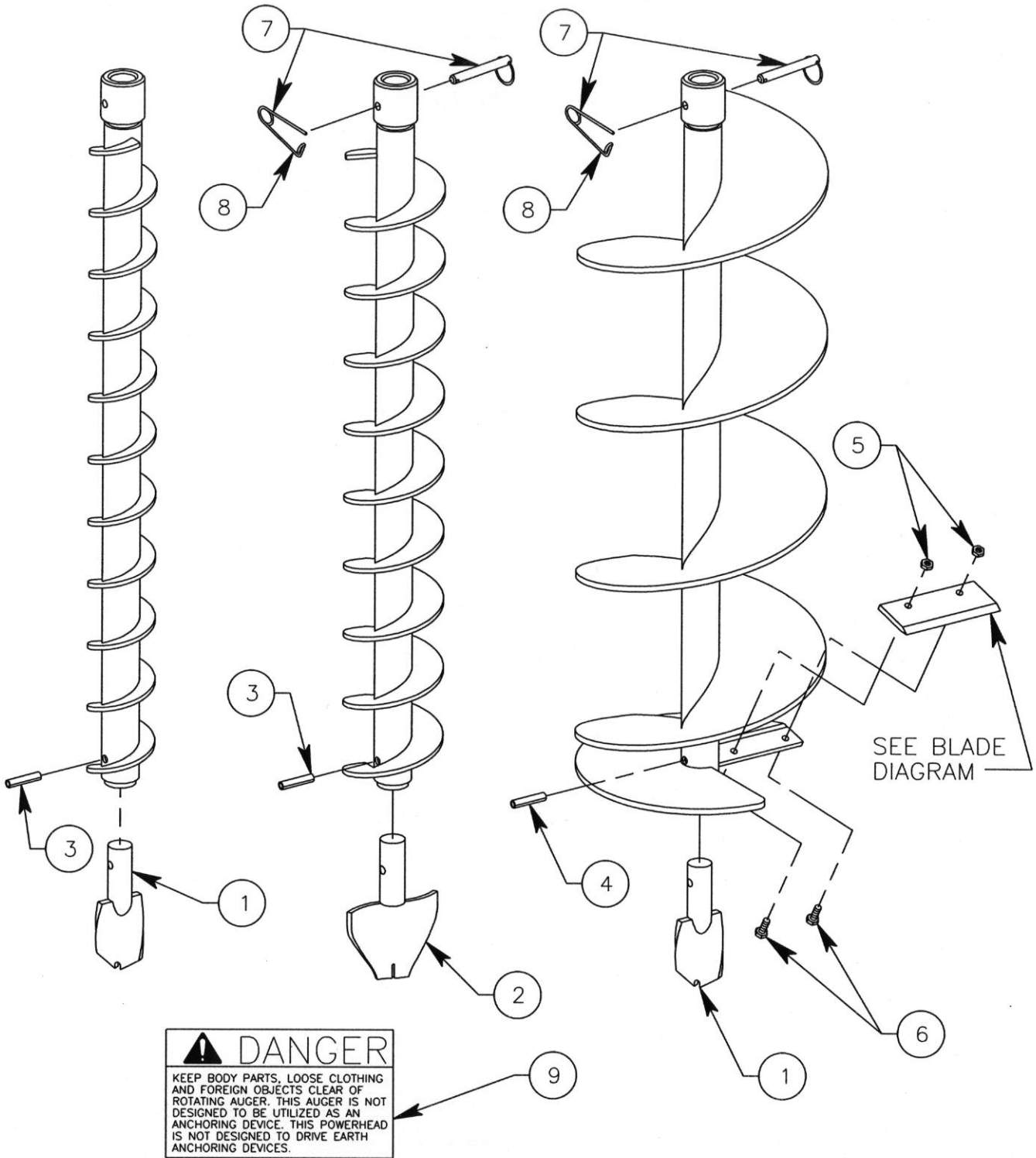

⚠ DANGER
KEEP BODY PARTS, LOOSE CLOTHING
AND FOREIGN OBJECTS CLEAR OF
ROTATING AUGER. THIS AUGER IS NOT
DESIGNED TO BE UTILIZED AS AN
ANCHORING DEVICE. THIS POWERHEAD
IS NOT DESIGNED TO DRIVE EARTH
ANCHORING DEVICES.

Replacement Parts Diagrams

2135 Series Earth Augers

1" Diameter Round Drive Connection
For Use With 210/240 Series Hole Diggers

REFERENCE NUMBER	PART NUMBER	DESCRIPTION	QTY	APPLICATION
1	P801	Bit, Screw	1	2135-2E Auger 2135-4E thru 2135-8E Augers
2	P302	Bit, Screw	1	2135-3E Auger
3	20051000	Pin, Roll, 5/16" x 1-1/4", Plain Finish	1	2135-2E and 2135-3E Augers
4	20051200	Pin, Roll, 5/16" x 1-1/2", Plain Finish	1	2135-4E thru 2135-8E Augers
5	52040000	Nut, Hex, 1/4" UNC, Two Way, Plated	2	2135-4E thru 2135-8E Augers
6	15040700	Screw, Cap, 1/4" x 7/8" UNC, Plated	2	2135-4E thru 2135-8E Augers
7	2121	Pin, Auger (Includes P/N AP-21-S)	1	All Augers and 2135-15X Extension
8	AP-21-S	Pin, Safety	1	All Augers and 2135-15X Extension
9	233-5092	Decal, Danger	1	All Augers and 2135-15X Extension

Replacement Blade Diagrams For Use With 2135 Series Earth Augers

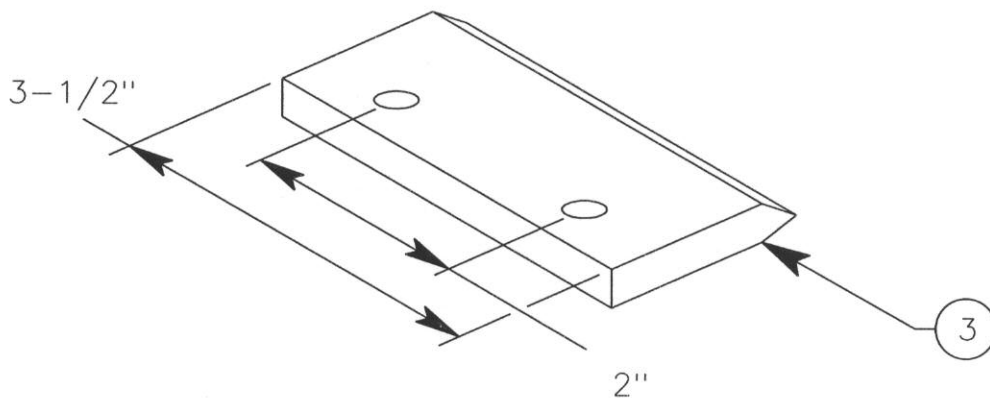
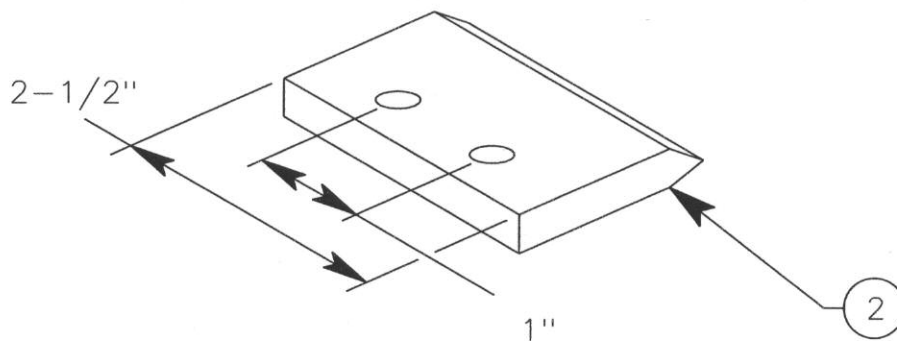
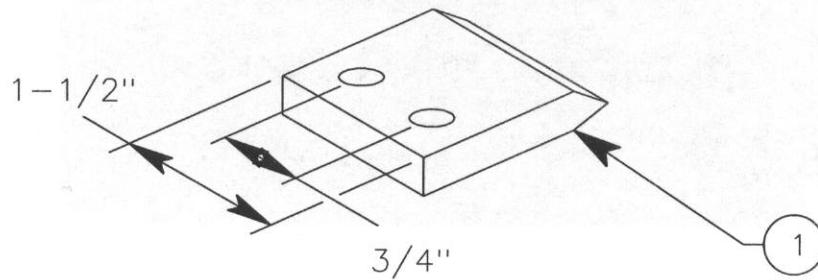

REFERENCE NUMBER	PART NUMBER	DESCRIPTION	QTY	AUGER APPLICATION
1	E244	Blade, Earth, 4" Dia. Auger	1	2135-4E
2	E246	Blade, Earth, 6" Dia. Auger	1	2135-6E
3	E248	Blade, Earth, 8" Dia. Auger	1	2135-8E

Display Stand Assembly 210/240 Series Hole Diggers

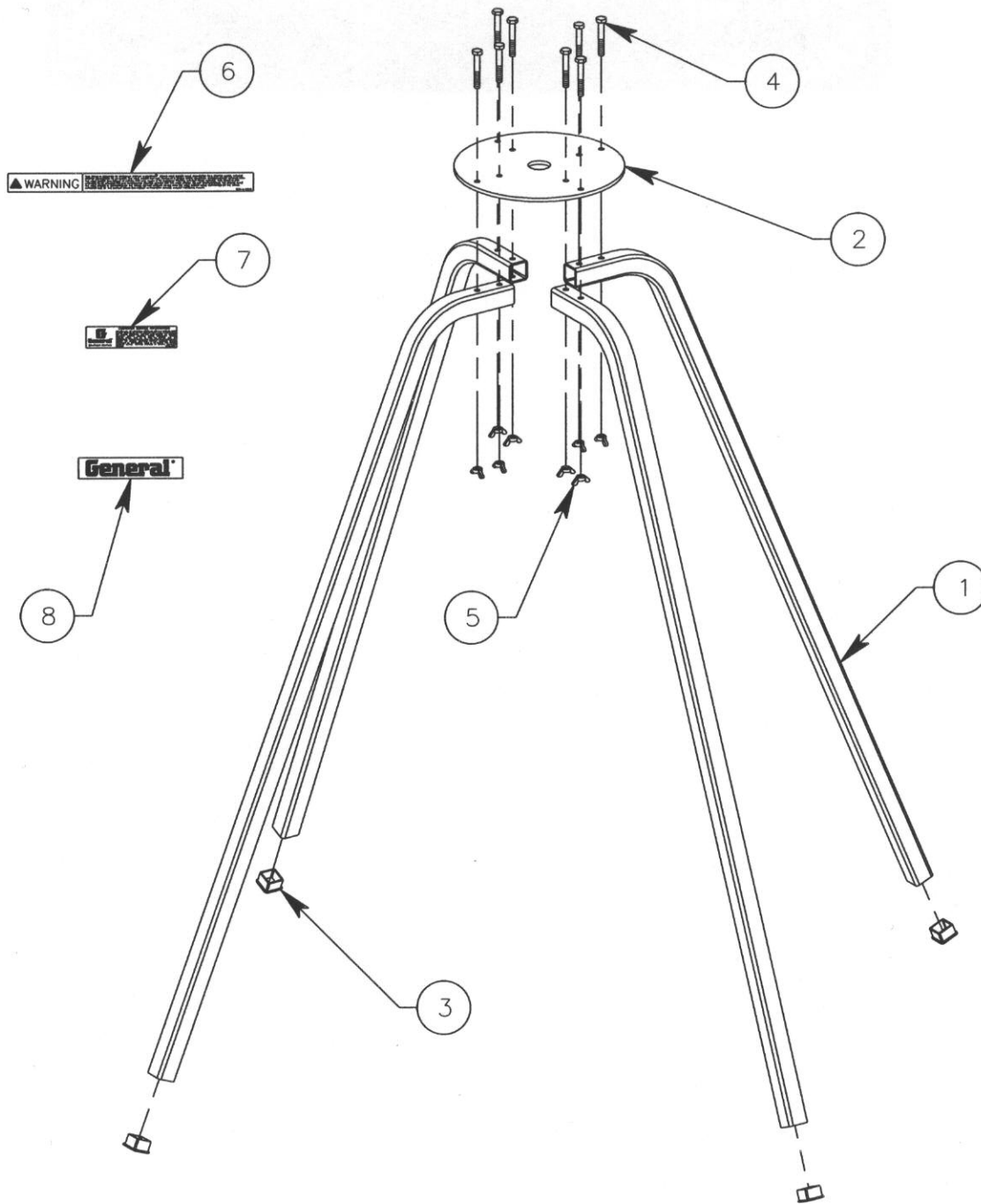

Display Stand Assembly 210/240 Series Hole Diggers

REFERENCE NUMBER	PART NUMBER	DESCRIPTION	QTY
1	999-4-010	Leg, Stand	4
2	999-4-020	Plate, Top	1
3	FP-164	Cap, Plug, 1" Square	4
4	15041400	Screw, Cap, 1/4-20 UNC x 1-3/4" Long, Plated	8
5	43040000	Nut, Wing, 1/4-20 UNC, Plated	8
6	999-4-5010	Decal, Warning	1
7	SG24-5070	Decal, Assistance	1
8	440-5010	Decal, General	1

**Plastic Body Series 314
Magura® Throttle Control Assembly
240/300 Series Hole Diggers**

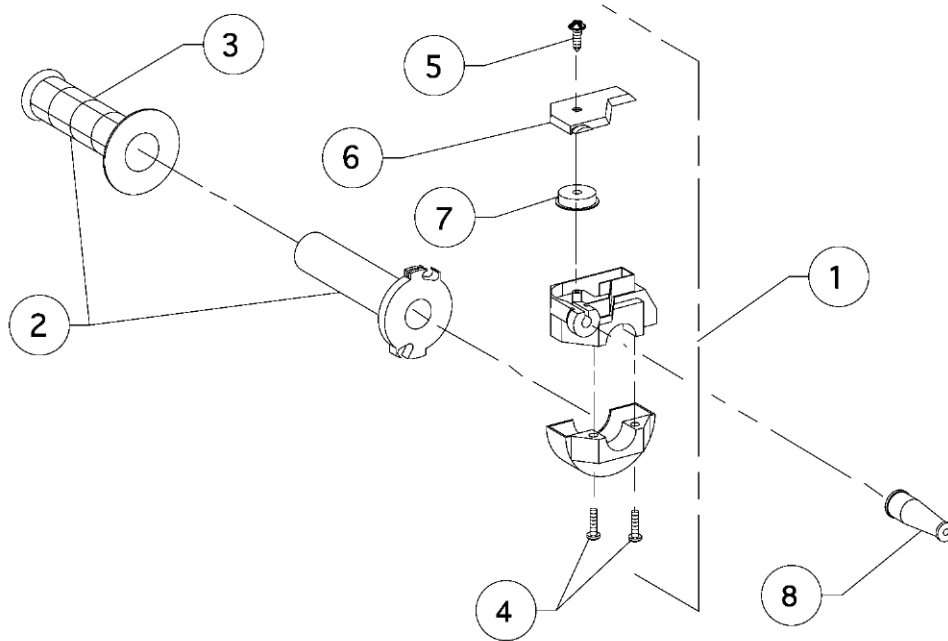

**Plastic Body Series 314
Magura® Throttle Control Assembly
240/300 Series Hole Diggers**

Reference Number	PART NUMBER	DESCRIPTION	QUANTITY
1	310-0030-010-A	Body Assembly, (Includes P/N 310-0030-040, Qty 2)	1
2	310-0030-020-A	Tube, Throttle (Includes P/N 310-0020-030)	1
3	310-0020-030	Grip, Handle	1
4	310-0030-040	Screw, Pan Head, M5 x 20	2
5	310-0030-050	Screw, Self Tapping	1
6	310-0030-060	Cover, Top	1
7	310-0030-070	Sheave, Roller	1
8	310-0020-080	Boot, Rubber	1