

# ***COMBI 350***

SAWING MACHINE

OPERATING, MAINTENANCE, SPARE PARTS MANUAL

**IMER U.S.A. Inc.**

207, Lawrence Avenue  
South San Francisco, California 94080  
(650) 872-2200

**09/2003 - R5**

- Cod. 3214816 -

Fig. 1 MACHINE LAY-OUT	
1	TELESCOPIC LEG
2	SPRAY GUARD
3	MOTOR
4	BLADE SUPPORT ARM
5	WATER PUMP
6	GUIDE
7	MAIN SWITCH
8	WORKTABLE
9	WATER TANK
10	BLADE GUARD
11	EARTHING SCREW
12	HEAD BLOCKAGE

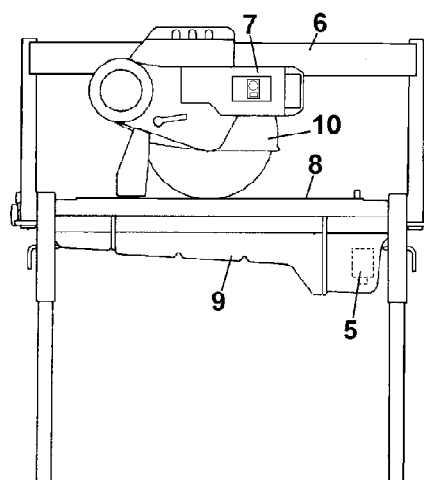
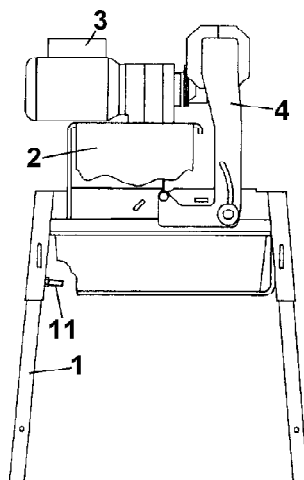

Fig. 1 - Machine Lay-out

Dear Customer,

Congratulations on your choice of purchase: IMER saws are the result of years of experience and is equipped with all the latest technical innovations.

**WORKING IN SAFETY**

To work in complete safety, read the following instructions carefully.

- This OPERATION AND MAINTENANCE manual must be kept on site by the person in charge, e.g. the SITE FOREMAN, and must always be available for consultation.

- The manual is to be considered integral part of the machine and must be kept for future reference (EN 292/2) until the machine is disposed of. If the manual is damaged or lost, a replacement may be requested from the saw manufacturer.

- The manual contains important information regarding site preparation, machine use, maintenance procedures, and requests for spare parts. Nevertheless, the installer and the operator must both have adequate experience and knowledge of the machine prior to use.

- To guarantee complete safety of the operator, safe operation and long life of equipment, follow the instructions in this manual carefully, and observe all safety standards currently in force for the prevention of accidents at work (use of safety footwear and gloves in accordance with S.I. N°3073 of 30/11/92).

**Pay special attention to warnings bearing the following symbol.**



**Safety glasses or a protective visor must be worn at all times.**



**MAKE SURE THAT SIGNS ARE LEGIBLE.**



**It is strictly forbidden to carry out any form of modification to the steel structure or working parts of the machine.**

- IMER INTERNATIONAL declines all responsibility for non-compliance with laws and standards governing the use of this equipment, in particular; improper use, defective power supply, lack of maintenance, unauthorised modifications, and partial or total failure to observe the instructions contained in this manual.

**2. DESIGN STANDARDS**

COMBI 350 saws are designed and manufactured according to the following standards: I.E.C. 34.4; EN 89/392 (91/368/CEE); CEI EN 60204.

**3. NOISE EMISSION LEVEL**

Operator exposure to sound emission levels (continuous sound pressure levels equal to "A" weighting); the COMBI 350 saw noise emission level during cutting is 93 dB(A) with continuous rim blade.

**4. CUTTING SPECIFICATIONS**

This saw model has been specially designed by IMER for cutting stone, ceramics, marble, granite, concrete and similar materials. Only water-

cooled diamond blades with continuous or segmented edges must be used. Under no circumstances must dry cutting blades be used or materials other than those specified above. IMER INTERNATIONAL declines all responsibility for damage caused by improper use of the above machine.

TECHNICAL DATA	COMBI 350		
		350/600	350/1000
Blade rpm	rpm	2150	2040 / 2150
Blade diameter	inc	14"	
Blade mounting hole	inc	1"	
Motor rating	Hp	3.0	1.5 / 3.0
Motor rpm	rpm	3450	3260 / 3450
Cutting table dimensions	inc	20" x 31"	20" x 46"
Overall dimensions	inc	47" x 34" x 51"	63" x 34" x 51"
Overall dimensions for transport	inc	51" x 28" x 37"	67" x 31" x 37"
Weight	lb	253	287
Weight for transport	lb	298	342
Blade rotation direction (seen from blade clamping flange)		ANTI - CLOCKWISE	
Current	A	11	13.4 / 11
Voltage	V	230	115 / 230
Frequency	Hz	60	

**5. CUTTING CAPACITY**

- Max. thickness (inc): 5" (90°); 3" (45°)
- Workpiece width (inc): max. 20" ; min 2"
- Length:

	COMBI 350/600	COMBI 350/1000
thk. x l (inc)	1" x 24"	1" x 40"
	3" x 22"	3" x 38"
(*) 90° cut from above	5" x 21"	5" x 37"
	5" x 28" (*)	5" x 43" (*)
(**) 45°	45 x 21" (**)	70 x 37" (**)

**6. WARNING**



- Do not load the saw with workpieces that exceed the specified weight (max. 90 lb).
- Ensure stability of machine and workpiece before, during or after cutting. Install supplementary support surfaces at the same height as the worktable.
- Respect the environment; use suitable receptacles for collection of cooling water contaminated with cutting dust.

**7. SAFETY PRECAUTIONS**

IMER saws are designed for work on construction sites and under conditions of natural light and in workshops under conditions of natural or artificial lighting of minimum 500 LUX.

 **The machine must never be used in environments subject to risks of explosion and/or underground sites.**

- IMER saws may only be used when fitted with all required safety devices which must be in perfect condition.
- Never use makeshift and/or faulty power cables.
- Make electrical connections on the construction site where they will not be subject to damage. Never stand the saw on power supply cables.
- Lay power cables where they are not subject to risk of damage or contact of connectors with water. Only use connectors fitted with water-spray protection (IP55).
- Repairs to electrical installations must only be carried out by qualified technicians. Always ensure that the machine is disconnected from the power supply and is completely immobile during repairs and maintenance operations.

 - **Connect the machine to a suitable equipotential earthing plant on the construction site with wire braid of minimum 16 mm<sup>2</sup> section. The connection point is identified by a screw welded to the frame (see Fig.1), and on the rating  plate by the earthing symbol.**

 - **Stop the saw only by means of the main switch.**



The symbol shown on the label (see left) indicates the warning "ENSURE ALL PROTECTION DEVICES ARE INSTALLED AND IN PERFECT CONDITION BEFORE SWITCHING ON THE MACHINE"

### 8. ELECTRICAL SAFETY

- IMER saws comply with EN 60204-1; and are fitted with:
- protection device against automatic re-start after power failure;
  - Short-circuit cutout device;
  - Motor overload cutout switch.

### 9. TRANSPORTATION (Ref. Fig.2)

 **WARNING! Always remove the plug from the power socket before moving the saw, and lock head support carriage movement by means of the relative knob (ref. 3). To transport the machine use slinging equipment with 4 rope legs, fixing the hooks to the relative attachments.**

### 10. INSTALLATION (Ref. Fig.2)

- Fix the hooks to the relative attachments on the machine and lift the machine out of its package.
- Unlock the legs by sliding out split pins (ref.2) and pins (ref.1).
  - Lock the legs at working height. Refit the pins in the leg supports and insert the split pins.
  - Install the machine on a completely even and stable surface.

### 11. ELECTRICAL CONNECTION

 **Ensure that there is an overload cutout device fitted up-line on the power line. If necessary, install an IMER quick connect residual current circuit breaker (RCCB) (code no. 1169245 available in kit form for 230V machines).**

Ensure that the mains voltage corresponds to that specified for the machine: 230V/60Hz - 115V/60Hz.

 **All power supply installations must comply with CEI 64-8 standards (harmonised document CENELEC HD384).**

The electrical power cable must be suitably sized to avoid voltage drops. Cable drums (with collector rings) must not be used. Cable dimensions will vary according to the start-up current and length of cable. In general cable sizes of 4 mm<sup>2</sup> are sufficient for lengths up to 160 ft. After installation always carry out voltage testing under load conditions, both at start-up and during operation. During operation, voltage drops must never exceed 5%. In the case of longer cables or a power supply network subject to variations, use cables with a section of at least 6 mm<sup>2</sup>. Cables used on construction sites must be fitted with suitable external sheathing that is resistant to wear, crushing and extreme weather conditions.

### 12. MACHINE START-UP

Before connecting the machine to the power supply:

- 1 - Ensure that the metal structure is connected to an earthing plant as indicated in Section 7 "Safety Precautions".
- 2 - Ensure that the tank contains sufficient cooling water.
- 3 - Ensure that the power circuit corresponds to the requirements as indicated in Section 11 "Electrical connections"
- 4 - Connect the machine to the power supply.

- 5 - Set the switch to "1" and when the motor is started return to position "0" after ensuring that cooling water reaches the blade.
- 6 - Check that the direction of blade rotation corresponds to that indicated by the arrow on the blade guard.
- 7 - If all is in order, proceed with cutting.

### 13. EMERGENCY STOP

 - **In the event of emergency, stop the machine by pressing the stop control switch.**

 - **The motor is fitted with an overload cutout device. If the motor overheats, it will automatically shut down. Allow motor to cool before re-starting.**

 - **The motor is protected against automatic re-start after interruptions due to power failure. To resume operation, when power is re-connected, repeat machine start-up procedure.**

### 14. BLADE INSTALLATION (Ref. Fig.3)

By means of a hex wrench no. 10, remove front screws (ref. 1) and loosen the other two screws (ref.2) which secure the blade guard. Turn the guard clockwise to gain access to the securing screw (ref.4). Use a hex wrench no. 13 to remove the screw (turn anti-clockwise). Remove the mobile flange and check that the flanges, disc shaft and blade are not damaged.

 - **Never use worn blades.**

 - **Only use blades that are designed for the number of revolutions indicated on the machine rating plate.**

 - **Check that blade rotation corresponds to that indicated on the blade guard.**

Centre the blade against the fixed flange, position the mobile flange and tighten the securing screw by means of a hex wrench no. 13 (turn clockwise). Return the guard to its original position and lock by means of screws (ref. 1 and 2).

 - **Ensure that the blade guard is locked securely into position.**

 - **WARNING! An incorrectly installed blade, or a screw insufficiently tightened can provoke damage to the machine or injury to persons.**

 - **Note that the blade must have an external diameter of 350 mm, a central hole diameter of 25.4 mm and max. thickness of 3 mm.**

 - **Check that the blade to be used is suitable for the material to be cut.**

### 15. USE

 **Leave a space of 5 ft around the machine to operate in full safety.**

- Do not allow other persons to approach the machine during cutting.
- Never use the machine in fire-risk areas. Sparks can cause fire or explosions.
- Make sure that the machine is switched off before positioning or handling.
- Always ensure that the blade is free of any contact before start-up.
- Ensure correct installation of all protective devices.

 - **Ensure that blade rotation corresponds to the indications on the blade guard.**

Before starting work, fill the water tank. Top up during operation whenever necessary: **N.B. the pump suction hose must always remain immersed in water.**

Insert the plug in the power socket.

 **WARNING! For safety purposes the removal of protective guards from the machine is strictly prohibited! The machine is protected against overload.**

 **WARNING! Always switch off the machine before carrying out blade adjustment.**

#### 15.1 VERTICAL BLADE MOVEMENT (Ref. Fig. 4)

To raise or lower the blade, slacken knob (ref.2) by turning it anti-clockwise. Set blade support (ref. 1) to the required position and lock by tightening the knob fully (ref.2).

 **Ensure that the locking knob is tightened fully before starting work.**

#### 15.2 BLADE POSITIONING FOR 45° CUTS (Ref. Fig.5)

Slacken knob (ref. 1); the blade support arm (ref.2) is unlocked and so can be set to its limit position, i.e. inclined at 45° with respect to

the worktable. Tighten the knob fully to lock into position. To bring the blade back to the vertical position (pos.0) carry out the above operations in reverse order.

**⚠** **Ensure that the locking knob (ref.1) is tightened fully before starting work.**

**15.3 CUTTING**

- Before cutting, check that the blade is aligned with the cutting line.

- Place the workpiece on the worktable snugly against the fence.  
- Start the motor and wait until the water reaches the blade to begin cutting.

- Start cutting movement by pulling the carriage towards you by means of the relative handle (ref.1 fig.6).

**⚠** **As cutting thickness increases, the blade is subjected to greater stress. To avoid overloading the motor, the operator should continually check blade feed speed. The speed will also depend on the characteristics of the material being cut (hardness, toughness etc.).**

**15.3.1 CUTS WITH BLADE LOWERED FROM ABOVE**  
(Ref. Fig.8)

Bring the blade support to its highest position and lock. Position the workpiece on the worktable. Start the machine, unlock the blade support and begin vertical cutting until the blade reaches its lowest point. Lock the support once more and proceed with horizontal cutting.

**15.3.2 BLADE CHANGE**

To change the blade refer to section 14. **BLADE INSTALLATION.**

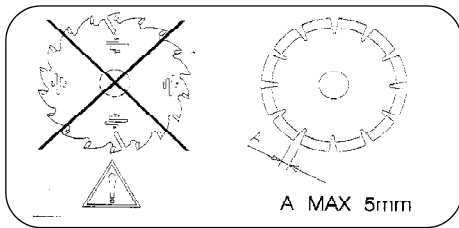

**⚠** **Do not use blades for wood or segmented disks with slots wider than 5 mm.**

**16. MAINTENANCE**

**⚠** **- WARNING! Always switch the machine off and remove the plug from the power socket before carrying out any maintenance operations .**

**⚠** **- Always check that the protective guards are in the correct position and in perfect condition.**

**⚠** **- As there is the continuous risk of inadvertent damage to the electric cables, these must be checked regularly each time before the machine is used.**

**⚠** **-WARNING! If the electric motor or control panel are removed for maintenance, it's necessary to replace the relevant seals in order to guaranty the right degree of protection and safety against water penetration inside to the electric circuits.**

Never leave the machine out in the open. Make sure that it is stored in a sheltered area away from extreme weather conditions. Replace worn or faulty components with original spare parts.

**⚠** **- WARNING! Recommend product for cleaning and lubricating the mechanical parts of the saw:**  
**WD-40**

**16.1 TANK CLEANING ON WORK COMPLETION**

On completion of work, empty the tank and remove. Clean thoroughly to remove cutting residue.

**16.2 TANK REMOVAL (Ref.Fig.7)**

Lift the tank (ref.1) to detach from its supports (ref.2) and remove from the side indicated by the arrow.

**16.3 WORK SURFACE CLEANING**

Always keep work surfaces clean. Residual dirt can impair cutting precision.

**16.4 GUIDE RAIL CLEANING**

The horizontal guide elements on the carriage are protected against dirt build-up by scrapers. However we advise thorough cleaning of the guide rails to ensure correct operation.

**⚠** **WARNING! Do not use any type of lubricant on the guide rail.**

**16.5 CARRIAGE CLEARANCE ADJUSTMENT (Ref. fig.9)**

**LATERAL ADJUSTMENT:** turn adjustment screw "1" gradually clockwise using a hex wrench no.3, so that the internal roller comes into contact with the bar. Take care not to exert too much pressure. Repeat the same operation with the other adjustment screws according to the order indicated in the figure. Adjust vertical clearance by means of the screws located on the lower part of carriage (A). On completion, if carriage travel is not smooth, slacken the adjustment screws by turning the wrench anti-clockwise; if clearance has not been eliminated repeat the above operation.

**16.6 CLEANING AND MAINTENANCE OF COOLING CIRCUIT**

- If water does not reach the blade stop the machine immediately to avoid blade damage.

- After switching off the machine ensure that the water level is sufficient.

- If necessary, after disconnecting the machine from the power supply check that the tap, hose and pump filter are not blocked

- If necessary, check that the impeller rotates freely (after extended periods of disuse)

- If necessary, remove the pump and check that the pump/motor coupling is in perfect condition.

**16.7 DRIVE BELT REPLACEMENT**

- Disconnect the machine from the power supply

- Remove the water hose connection by loosening the hose clamp on the blade guard.

- Remove the blade, the two flanges, the blade half-guard securing screws, the locking knob (ref.1, chart 02) and remove the blade external half-guard (motor side).

- Remove the blade shaft with pulley from the bearing (ref.27, drawing 02) and fit into the bearing of the half-guard previously removed (ref.14, chart 02).

- Fit the new belt onto the two pulleys and refit the belt tensioner.

- Refit the seal on the edge of the guard and ensure that it is in good condition and that the two locating pins are in the correct position.

- Refit the guard inserting the blade shaft into the bearing (ref.27, chart 02) taking care to align the screw (ref.51, drawing 02) located on the slot of the head fulcrum (ref.19, drawing 02) with the locking handle hole (ref.1, drawing 02).

- Join the two blade half-guards using the two locating pins to align correctly.

- Screw in the two blade half-guards by tightening diagonally opposite screws alternately.

- Screw in and tighten the locking handle before installing the blade.

**17. TROUBLESHOOTING**

**⚠** **N.B.: Before carrying out any maintenance operations, switch off the machine, set the switch to "0" and remove the plug from the power socket.**

FAULT	CAUSE	REMEDY
<b>Motor does not start when switch is turned</b>	- Defective power cable - Plug not inserted in socket correctly - Power cable from plug to control panel detached - Loose wire inside motor circuit board - A wire has become disconnected inside the panel - Faulty main switch - The overload safety device has been activated.	- Check power cables - Ensure correct connection - Connect cable- re  -Connect wire - Remake the connection - Replace switch  -Wait for a few minutes and then try restarting the machine.
<b>Vertical blade movement not smooth</b>	- locking knob too tight	- Slacken knob
<b>Blade inclination not smooth</b>	- locking knob too tight	- Slacken knob
<b>Horizontal carriage movement not smooth</b>	- Locking knob too tight. -Incorrect guide wheel adjustment .	- Slacken knob - Adjust (Chapter 16.8)
<b>Lack of cooling water supply to blade</b>	Refer to section: "cleaning and maintenance of cooling circuit"	
<b>Blade does not cut</b>	- Incorrect blade rotation  - Blade is worn	- Remove the blade and refit in the position as indicated on the blade label. - Fit new blade
<b>Motor starts but blade does not rotate</b>	Belt is broken	Replace drive belt, see Chapter 16.6

Fig.2

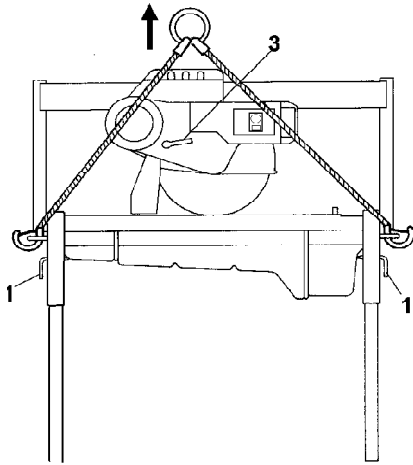

Fig.3

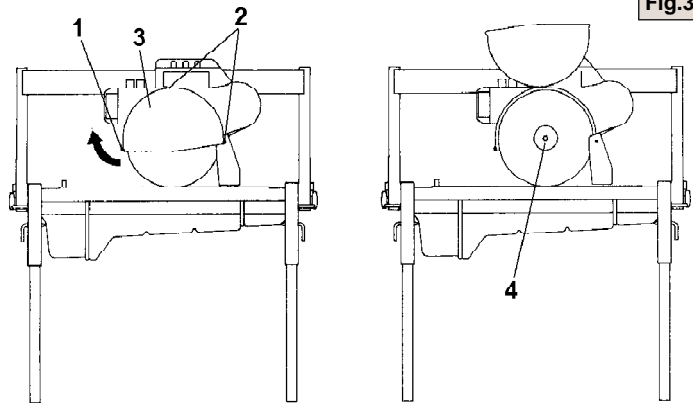

Fig.4

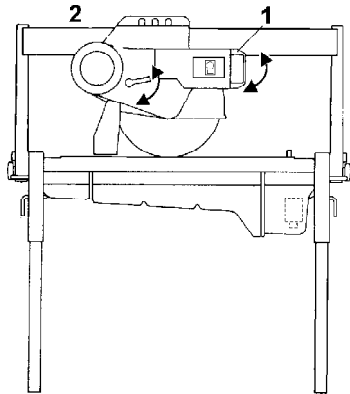

Fig.5

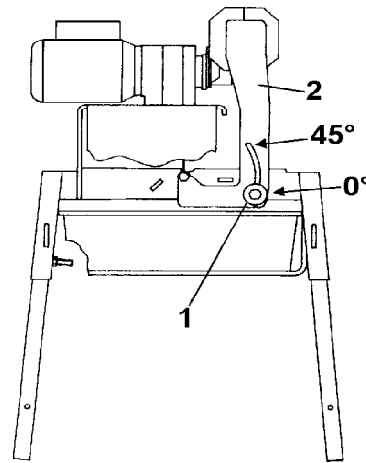

Fig.6

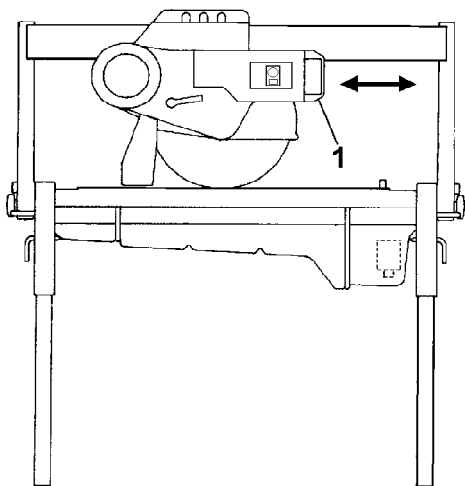

Fig.7

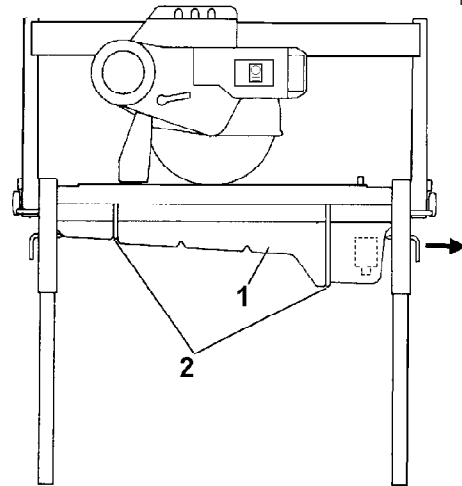

Fig.8

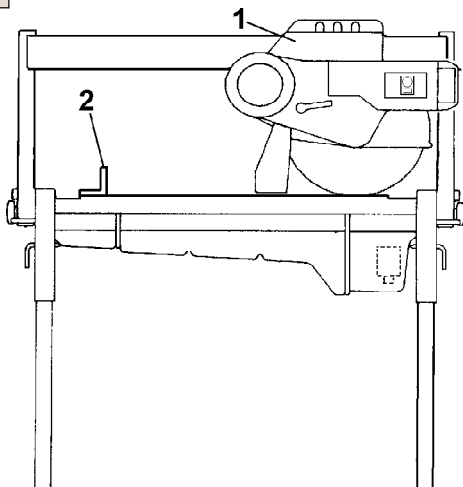
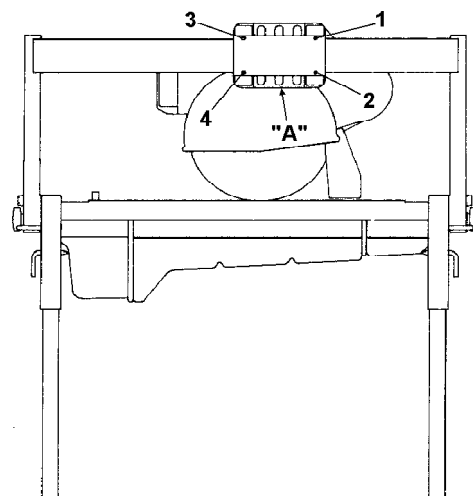

Fig.9



**18. SPARE PARTS** :All orders for spare parts must indicate the following: 1 - Type of machine.2 - Part number and position number of each part.3 - Serial number and year of manufacture reported on the machine's identification plate.

**SYMBOL:** Interchangeability (example):Pos.,1 P.n. 3204530 was installed on machings up to N° 5240 and Pos.1.1 P.n. 3204520 installed on machine N° 5241 onwards. Pos. 1.1 is interchangeable (    ) with Pos. 1.Pos. 1.1 are not interchangeable if the (   X   ) symbol appears in the table.

Rif.	Cod.	I	F	GB	D	E	Note
1	3204530	Riduttore	Réducteur	Reducer	Untersetzungsgetriebe	Reductor	5240
2	3204520	Riduttore	Réducteur	Reducer	Untersetzungsgetriebe	Reductor	5241

AK012 - AK013				TAB 1 - FRAME ASSEMBLY			
RIF.	COD.	USA	DETAILS	RIF.	COD.	USA	DETAILS
1	3205730	BOLT	5737 12X100	27	2223924	NUT	AUTOBL.DIAM.6
2	2224380	WASHER	6593 Ø12X25	28	3205470	END STOP	SX
3	3204743	HANDWHEEL		29	3205471	END STOP	DX
4	2224340	WASHER	6592 Ø10X20	30	2222515	BOLT	5931 M 8X16
5	3205699	BOLT	5911M10x600	31	3214696	FRAME	COMBI 600
6	3232701	ROTARY BLADE ARM	DX		3214713		COMBI 1000
7	3232703	CARRIAGE	DX	32	2228840	PIN	
8	2222137	BOLT	5739 M16x50	33	3201517	COLLAPSIBLE LEG	
9	3232746 3205457	GUIDE BAR	COMBI 600 COMBI1000	34	3205577	WATER RUN-OFF TRAY	COMBI 600
10	2265675	DAMPER			3205469		COMBI 1000
11	3205502	PIN		35	3204818	DRUM	
12	3206209	BEARING	6001 2RS	36	2235428	PLUG	
13	3206521	SPACER		37	3208737 3209317	PUMP	230V-60Hz 115V-60Hz
14	3232736	PIN		38	2292365	TUBE	
15	2222088	BOLT	5737 M8X40	39	3206318	SUPPORT	
16	3205464	FRONT SCRAPER		42	3214195	SPRAY GUARD	
17	3232704	CARRIAGE	SX	44	2223921	NUT	AUTOBL.M 12
18	2223570	NUT	5588 M 8	45	2222056	BOLT	5739 M 10X25
19	2222021	BOLT	5739 M 6X16	46	2223650	NUT	5588 M 10
20	2228820	PIN		47	2241570	SPANNER	
21	3205465	REAR SCRAPER		48	3205788	SPANNER	
22	2222061	BOLT	5739 M 8X20	49	3206210	WHEEL	
23	3232702	ROTARY BLADE ARM		50	2204421	BEARING	6201 2RS
24	3205481	CUTTING TABLE	COMBI 600 DX	51	3206085	HANDWHEEL	
	3205467	CUTTING TABLE	COMBI 1000 DX	52	3207219	GONIOMETER	
	3205482	CUTTING TABLE	COMBI 600 SX	53	3205465	FILZ	
25	3205468	CUTTING TABLE	COMBI 1000 SX	54	3205464	FILZ	
26	2222545	BOLT	5931 M 6X30	55	3201015	PLUG	

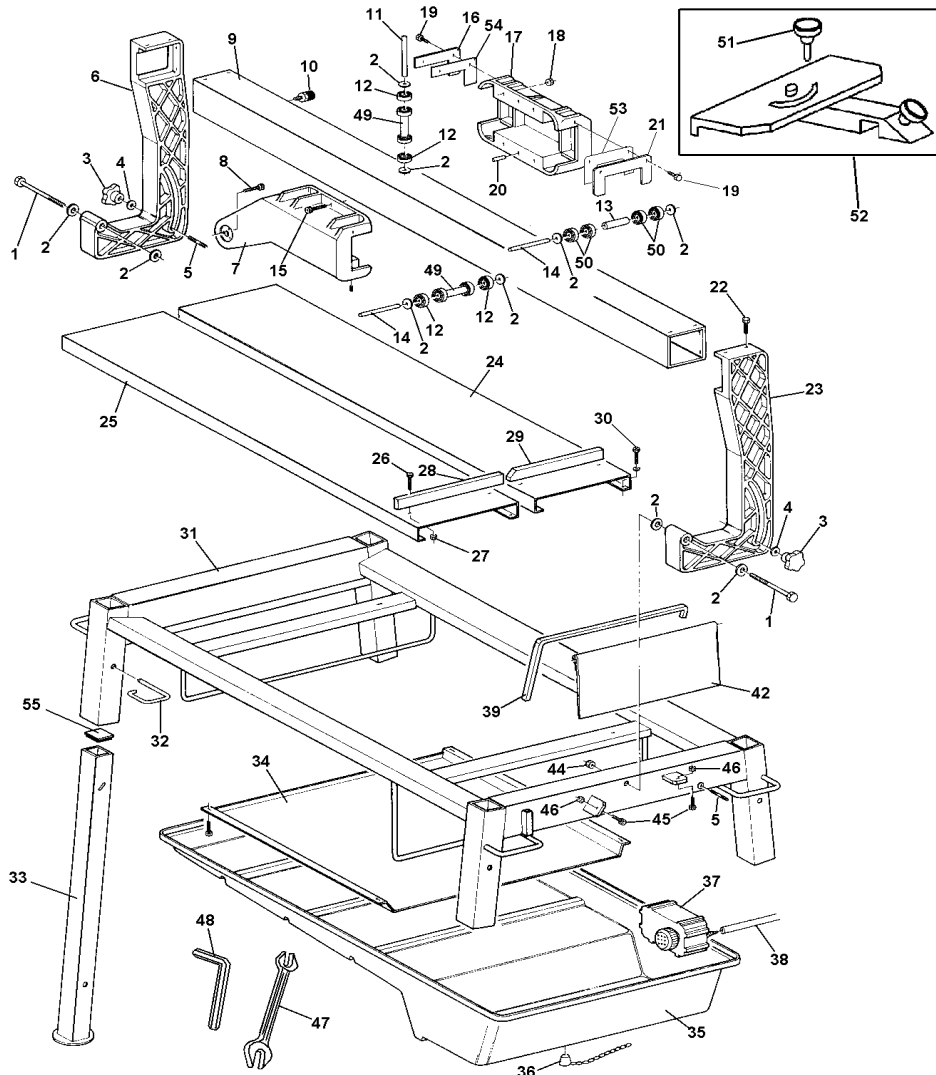

AK014		TAB. 2 MOBILE HEAD ASSEMBLY	
RIF.	COD.	USA	DETAILS
1	2284827	HANDLE	
2	2224380	WASHER	6593 Ø12X25
3	2222541	BOLT	5931 M 6X25
4	2223045	NUT	M10 5721-69
5	3232761	COVER	
6	3214191	BOLT	5737 M10X50
7	3214655	BEARING	6000 2RS
8	3203910	ROLLER	6592 Ø10X20
9	3214198	WASHER	"SS" DIN988 10X16X1,6
10	3214193	BELT TENSIONER ARM	
11	2222148	BOLT	5737 M 10X65
12	2223920	NUT	AUT. M10 7474
13	3214202	SPRING	
14	3206514	BEARING	6203 2RS
15	3204737	BELT	
16	3204736	PULLEY	
17	3206739	BLADE SHAFT-PULLEY	
18	2222016	BOLT	5739 M 6X20
19	3232740	HEAD FULCRUM	
19	3206488	HEAD FULCRUM	
20	2204510	BEARING	6009 2RS
21	2228820	PIN	6x14
22	3204788	PIN	
23	3204787	SPRING	
24	3207366	COMPENSATING RING	
27	2204540	BEARING	6205 2RS
28	3232759	OIL SEAL RING	35X52X7
31	2222544	BOLT	5737 M 6X60
32	2224531	WASHER	6593 Ø 6X18
33	2223924	NUT	AUTOBL. M 6
34	2247898	SPRAY GUARD	
35	3205635	VALVE	
36	3232763	TUBE	
37	2222709	BOLT	5739 M 5X10
38	3232762	SUPPORT	
41	2284826	HANDLE	COMBI600-MASONRY
42	2222515	BOLT	5931 M 8X16
43	3204777	INNER FLANGE	
45	3204776	OUTER FLANGE	
46	2224140	WASHER	6593 Ø 8X18
47	2222060	BOLT	5739 M 8X20
48	3204775	BLADE COVER	
49	2222021	BOLT	5739 M6X16
50	3207128	LABEL	
51	3203914	BOLT	TTQ M12X80
52	3232742	GASKET	
53	3206131	WASHER	3545 Ø16x35x1,4
54	3213268	SHOCK ABSORBER	
55	2222537	BOLT	M6X10 Z
56	2224530	WASHER	6592 Ø 6X12,5

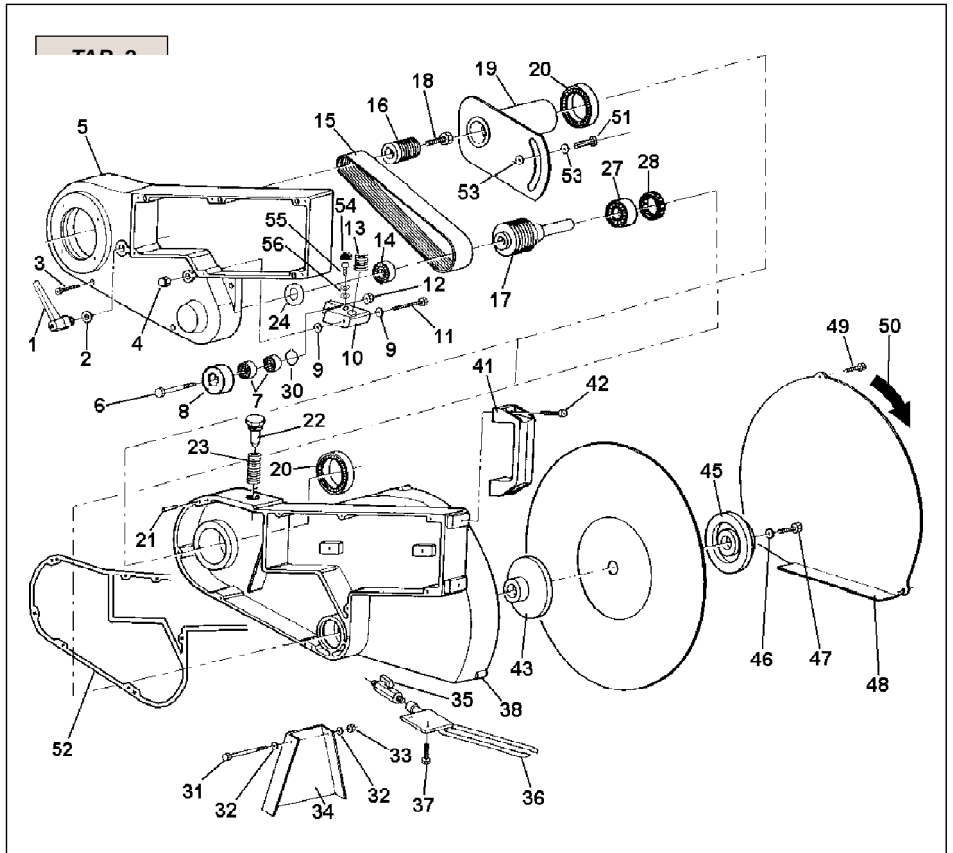

AK014		TAB. 3 ASSEMBLY OF MOTOR	
RIF.	COD.	USA	DETAILS
1	3214262	CAPACITOR	115V/60HZ
	2285601		230V/60HZ
2	3207920	CONTACTOR	
3	3207927	COIL	115V/60HZ
	3207924		230V/60HZ
4	3201503	CABLE-CLAMP	
5	3207933	COVER	
6	3232743	GASKET	
7	3200412	BOLT	
8	3207934	MOTOR	115V/60Hz
	3207937		230V/60Hz
9	3205924	LABEL	
10	3207929	JUNCTION BOX	
11	3207928	PUSH	
12	3232270	GASKET	
13	1222252	BOLT	
14	3201217	CABLE-CLAMP	
15	3207184	PLUG	115V/60Hz
	3208070		230V/60Hz
16	3206171	SWITCH COVER	
17	3206170	WATER PUMP SWITCH	

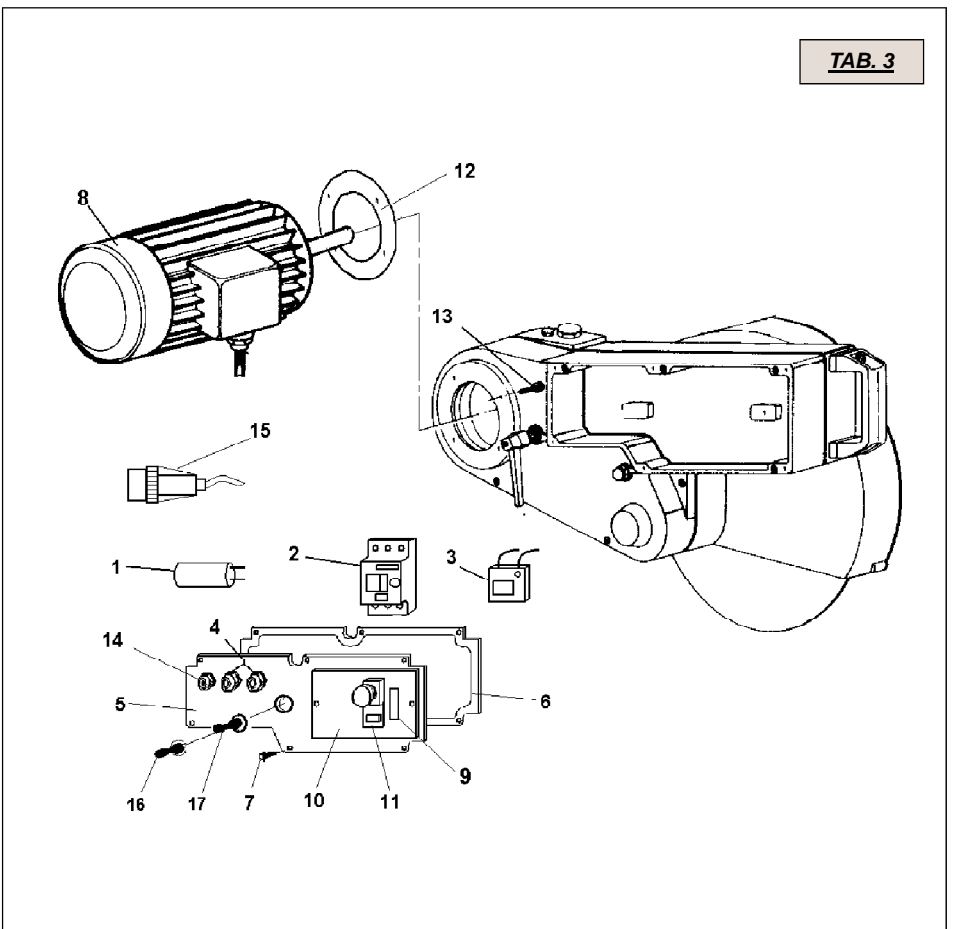

AK014		TAB. 4.1 ASSEMBLY OF MOTOR	
RIF.	COD.	USA	DETAILS
1	3203680	MOTOR FLANGE	115V/60Hz
	3204830		230V/60Hz
2	2222970	BOLT	115V/60Hz
	2222911		230V/60Hz
3	2223352	NUT	115V/60Hz
	2223280		230V/60Hz
4	3213619	CASING AND STATOR	115V/60Hz
	3216622		230V/60Hz
5	3214262	CAPACITOR	115/60 MF80 V250
	2285601		230/50 MF35 V450
6	2281955	TERMINALS	115/60 230/60
7	2227900	SPLIT RING	115V/60Hz
	2237340		230V/60Hz
8	2204390	BEARING	115V/60Hz: 6204 2Z
	2204391		230V/60Hz: 6205 2Z
9	2229325	KEY	6X6X25 6604
10	3203681	ROTOR	115V/60Hz
	3204829		230V/60Hz
11	2291495	COVER	115V/60Hz
	2291494		230V/60Hz
12	2227097	OIL SEAL RING	115V/60Hz
	3214031		230V/60Hz
13	2291453	MOTOR FAN	115V/60Hz
	2291454		230V/60Hz
14	2291281	FAN COVER	115V/60Hz
	2291282		230V/60Hz
15	2216321	GASKET	
16	3213032	COVER	
17	3204411	CABLE CLAMP	IP68 PG16
18	3214028	SEAL RING	Ø18,8X1,8 (PG16)
19	2222465	SCREW	TRILOB.M5X15
20	3203262	RATING PLATE	115V/60Hz
	3203980		230V/60Hz
21	2288792	RIVET	
22	3203678	MOTOR FLANGE	115V/60Hz

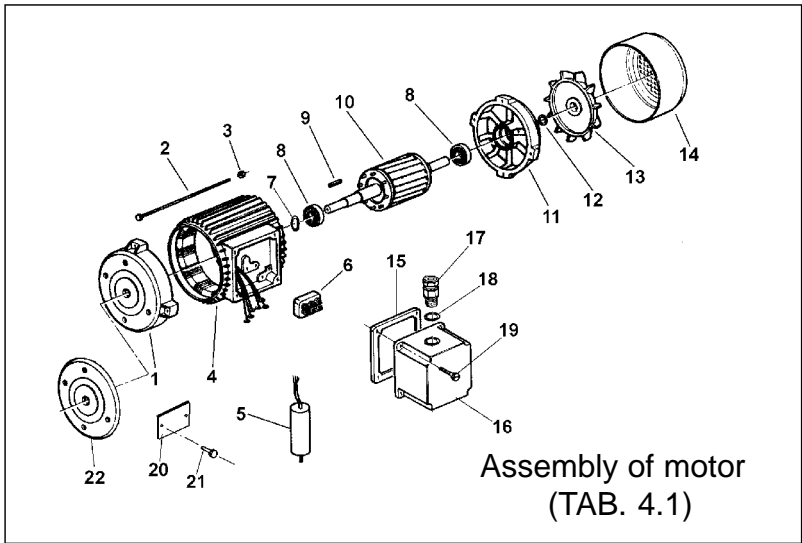

TAB. 1 - WHEEL KIT			
Rif.	Cod.	GB	DETAILS
1	2226700	SPLIT PIN	
2	2211150	WHEEL	
3	3206261	LEFT TUBE GUIDE	
4	3206262	RIGHT TUBE GUIDE	
5	2222082	SCREW	5739 M 10X60
6	2223650	DISK	5588 M10
7	3206641	WASHER	6592 28X50X2
8	3206260	WHEEL TUBE	

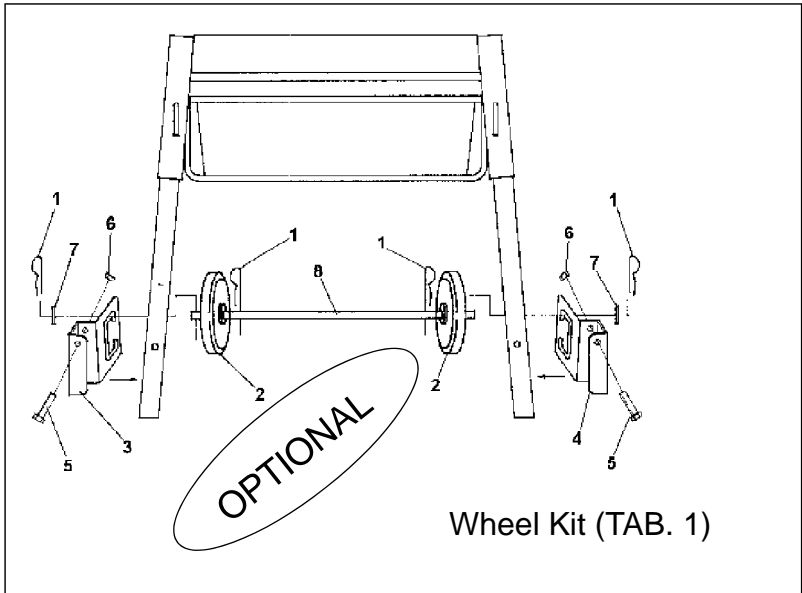
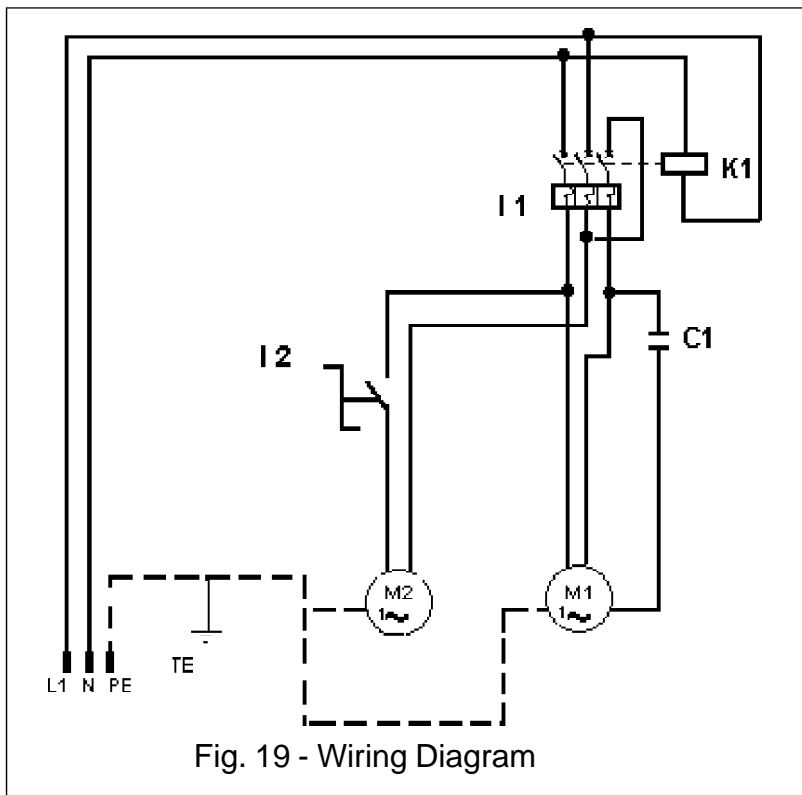

Fig.19	USA
L1	PHASE LINE CONDUCTOR
N	NEUTRAL LINE CONDUCTOR
PE	PROTECTION CONDUCTOR
I1	THERMO-MAGNETIC CUTOFF DEVICE
C1	MOTOR CAPACITOR
K1	COIL
M1	BLADE MOTOR
M2	PUMP MOTOR
I2	SWITCH



## ONE YEAR WARRANTY

We warrant to the original purchaser that the IMER equipment described herein (the "equipment") shall be free from defects in material and workmanship under normal use and service for which it was intended for a period of one (1) year from the date of purchase by the original purchaser.

Our obligation under this warranty is expressly limited to replacing or repairing, free of charge, F.O.B. our designated service facility, such part or parts of the equipment as our inspection shall disclose to be defective. Parts such as engines, motors, pumps, valves, electric motors, etc. furnished by us but not manufactured by us will carry only the warranty of the manufacturer. Transportation charges or duties shall be borne by the purchaser. This shall be the limit of our liability with respect to the quality of the equipment.

This warranty shall not apply to any equipment, or parts thereof, which has been damaged by reason of accident, negligence, unreasonable use, faulty repairs, or which has not been maintained and operated in accordance with our printed instructions for our equipment. Further, this warranty is void if the equipment, or any of its components, is altered or modified in any way.

THIS WARRANTY IS EXPRESSLY IN LIEU OF ALL OTHER WARRANTIES, EXPRESSED OR IMPLIED, INCLUDING ANY IMPLIED WARRANTY OF MERCHANTABILITY OF FITNESS FOR A PARTICULAR PURPOSE.

We make no other warranty, representation or guarantee, nor is anyone authorized to make one on our behalf. We shall not be liable for any consequential damage of any kind, including loss or damage resulting, directly or indirectly, from the use or loss of use of the machine. Without limiting the generality of the foregoing, this exclusion from liability embraces the purchase's expenses for downtime, damages for which the purchaser may be liable to other persons, damages to property, and injury or death of any persons.

This warranty shall not be deemed to cover maintenance parts, including but not limited to blades, belts, hoses, hydraulic oil or filters, for which we shall have no responsibility or liability whatsoever.

IMER U.S.A., Inc.  
207 Lawrence Avenue  
South San Francisco, California 94080  
(650) 872-2200