

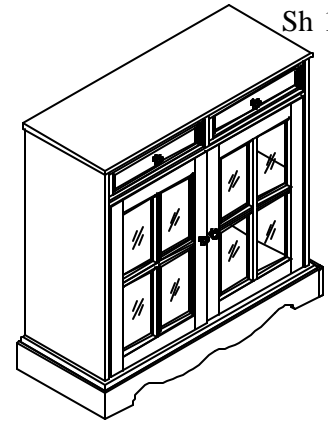









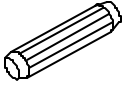
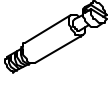

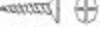

SOUTHERN ENTERPRISES INC.
 NOTE.... This product has been engineered for easy assembly and constructed for durability.
 Please take time to read through and follow assembly instructions.

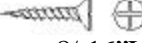

Style No.
KA4346

Description
2-DRAWER/2-DOOR MEDIUM OAK FINISH BUFFET
HARDWARE LIST

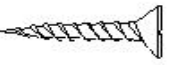
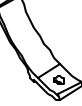
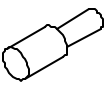
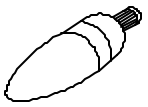
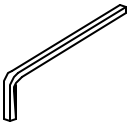
1. Wood Dowel 10 pcs 	2. Cam Bolt 6 pcs 	3. Cam Lock 6 pcs 	4. Wood Screw 16 pcs 10/ 16"L 	5. Wood Screw 8 pcs 9/16"L 
6. Short Wood Screw 40 pcs 6/ 16"L 	7. Door Knob 4 pcs 	8. Small Phillip Bolt 4 pcs 	9. Wood Screw 4PC 8/ 16"L 	10. Magnet 1 pc 
11. Glass Holder 40 pcs 	12. Round Head Short Screw 20 pcs 	13. Barrel Nut 4 pcs 	14. Allen Bolt 4 pcs 	15. Long Wood Screw 1 pc 1-1/4"L 
16. Drawer Stopper 2 pcs 	17. Shelf Support 4 pcs 	18. Glue 1 pc 	19. Allen Wrench 1 pc 	

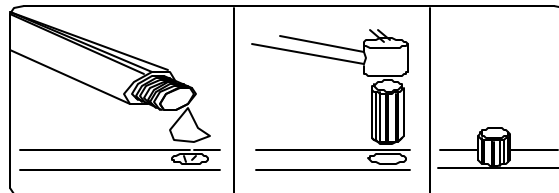
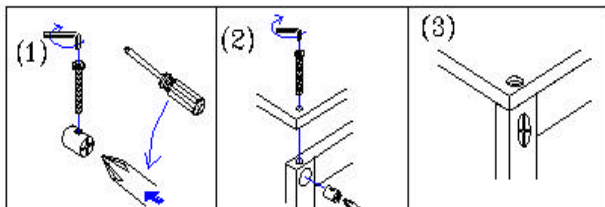
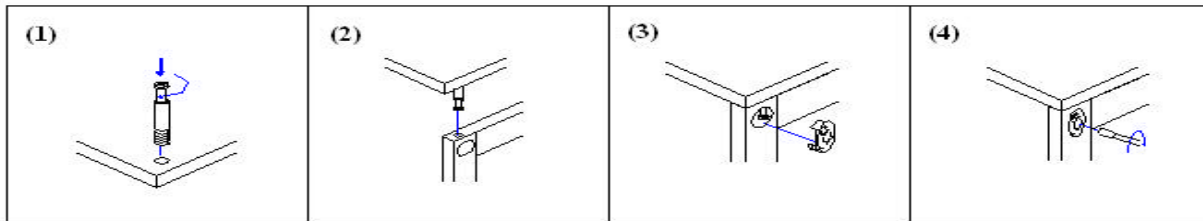

ADJUST BARREL NUT BY SCREW DRIVER TO LET HOLE STRAIGHT TO THE BOLT

APPLY GLUE 1/4 FULL INTO HOLES BEFORE WOOD DOWELL GOES INTO POSITION. PLEASE USE RUBBER-HEAD HAMMER ONLY WHEN NEEDED.

 Please count, identify and compare parts and hardware list to be sure all parts are present. It may help to divide parts and label them to correspond with part list. Extra hardware may be included. If any items are missing, please contact our parts/service department at (800) 633-5096 or in Dallas (972) 869-0111/ 9am – 4pm Mon-Fri Central time. Missing or damaged hardware and/ or parts will be replaced free of charge. WE DO NOT SELL PARTS. WE DO NOT RECOMMEND MODIFYING PRODUCT (S) AND WE ARE NOT RESPONSIBLE FOR ANY DAMAGES DUE TO PRODUCT MODIFICATION (S). If this product has not been purchased from our retail affiliates (within 9 months), we are under no obligation to provide parts or replacement merchandise.

Parts will not be available for items arriving fully assembled.

PARTS REPLACEMENT FORM

STYLE NO. KA4346
 Customer Name

PARTS LETTER	PART DESCRIPTION	QUANTITY NEEDED
-----------------	---------------------	--------------------

Street, City, State, Zip

Phone#



SOUTHERN ENTERPRISES INC.
 P.O. Box 59996 Dallas, Texas 75229

Please indicate where you purchased this item.
 Store/website/catalog

/ /
 Please indicate color/size/style number

/ /

PARTS LIST

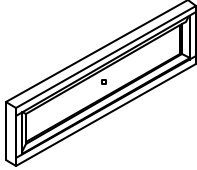
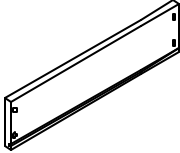
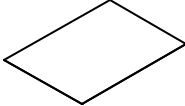
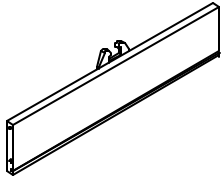
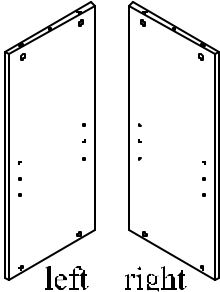
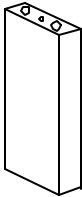
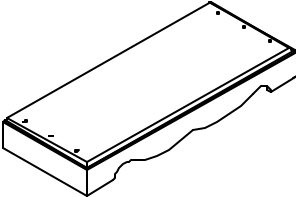
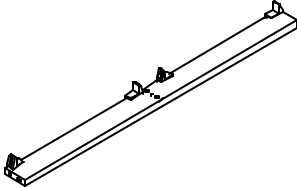
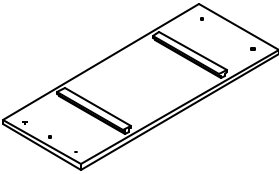
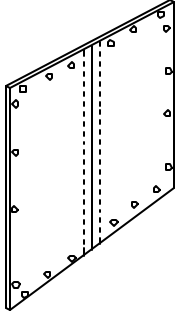
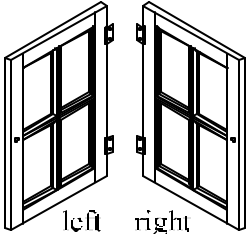
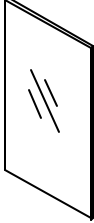
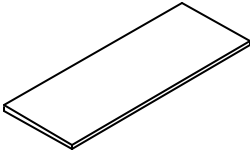
<p>(A)</p>  <p>Drawer Front Panel 2 PCS</p>	<p>(B)</p>  <p>Drawer Side Panel 4 PCS</p>	<p>(C)</p>  <p>Drawer Bottom Panel 2 PCS</p>	<p>(D)</p>  <p>Drawer Back Panel 2 PCS</p>
<p>(E)</p>  <p>left right</p> <p>EL: Left Side Panel 1 PC ER: Right Side Panel 1 PC</p>	<p>(F)</p>  <p>Middle Divider 1 PC</p>	<p>(G)</p>  <p>Bottom Panel 1PC</p>	<p>(H)</p>  <p>Front Rail 1 PC</p>
<p>(J)</p>  <p>Top Panel 1 PC</p>	<p>(K)</p>  <p>Taped Back Panel 1 PC</p>	<p>(L)</p>  <p>left right</p> <p>LL: Left Door Frame 1 PC LR: Right Door Frame 1 PC</p>	<p>(M)</p>  <p>Door Glass 8 PCS</p>
<p>(N)</p>  <p>Shelf Panel 1 PC</p>			

ASSEMBLY INSTRUCTIONS**STEP .1**

Fasten 2 Drawer Side Panels (B) to Drawer Front Panel (A) with four Wood Screw (4).

Slide Drawer Bottom Panel (C) in groove of Drawer Side Panels (B).

Please fasten Drawer Rear Panel (D) with four Wood Screw (4). **AS SHOWN, See FIG#1**

Connect and fasten Drawer Handle (7) to Drawer Front Panel (A) with Phillip Bolt (8)

NOTE: ALL GROOVES MATCH UP TO INSIDE. See FIG#1.

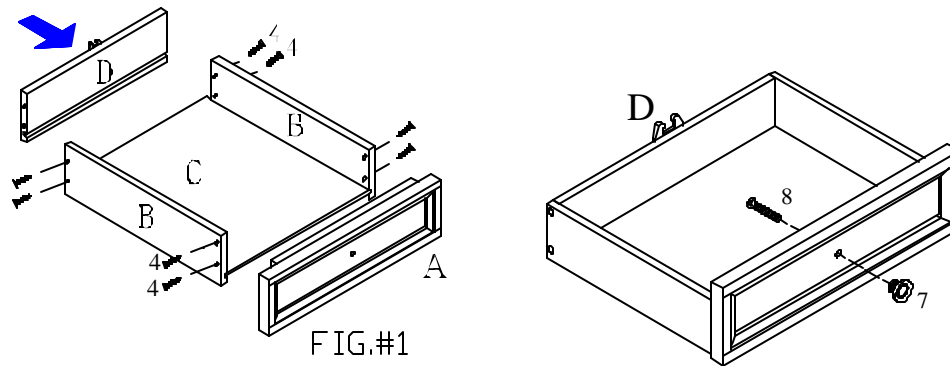

FIG.#1

STEP 2

Please insert Wood Dowel (1) into holes on following parts:

Both ends of Front Rail (H), both ends of Side Panels (ER & EL), and both ends of Middle Divider (F)

Please twist Cam Bolt (2) into pre-inserted nuts on top end of inner side of Side Panels (ER & EL). See FIG#2.

Please insert Wood Dowel (1) on Front Rail (H) into both side panels,

(There are 2 big hole on both ends of Front Rail (H) should facing downward. See FIG#2.)

Please inset Cam Lock (3) into holes on Front Rail (H), and then fasten to Cam Bolt (2).

Attach both side panels to Bottom Panel (G) by Wood Dowel (1) goes into holes on Bottom Panel (G).

Please insert Barrel Nut (13) into both inner sides of both side panels,

Then insert Allen Bolt (14) through Bottom Panel (G) to tighten to the Barrel Nuts (13) by Allen Wrench(19)

See FIG#2.

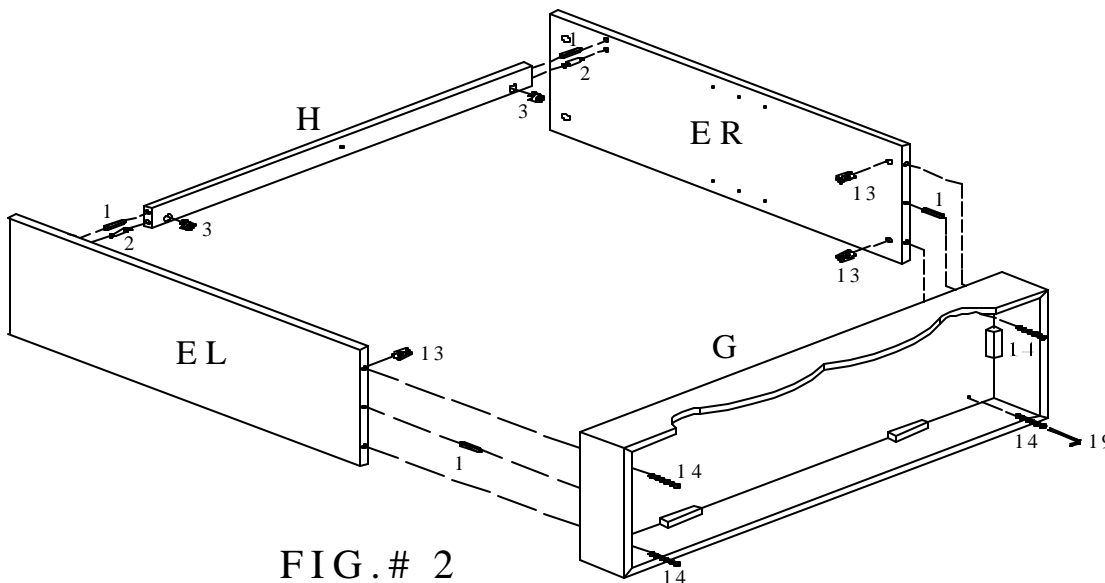

FIG.# 2

STEP 3

Assemble Drawer Stopper (16) to back side of Top Panel (J), tighten by Wood Screw (9).

Please twist Cam Bolt (2) into pre-inserted nuts on backside of Top Panel (J). See FIG#3.

Please insert Wood Dowel (1) on Middle Divider (F) into position on Front Rail (H), then insert Long Wood Screw (15) through Front Rail (H) to tighten together. See FIG#4.

Please attach Top Panel (J) onto position, do let all Wood Dowel (1) on both side panels and Middle Divider (F) Goes into hole on bottom side of Top Panel (J),

meanwhile the Cam Bolt (2) on Top Panel (J) should goes into holes on Side Panels (ER & EL) See FIG#4.

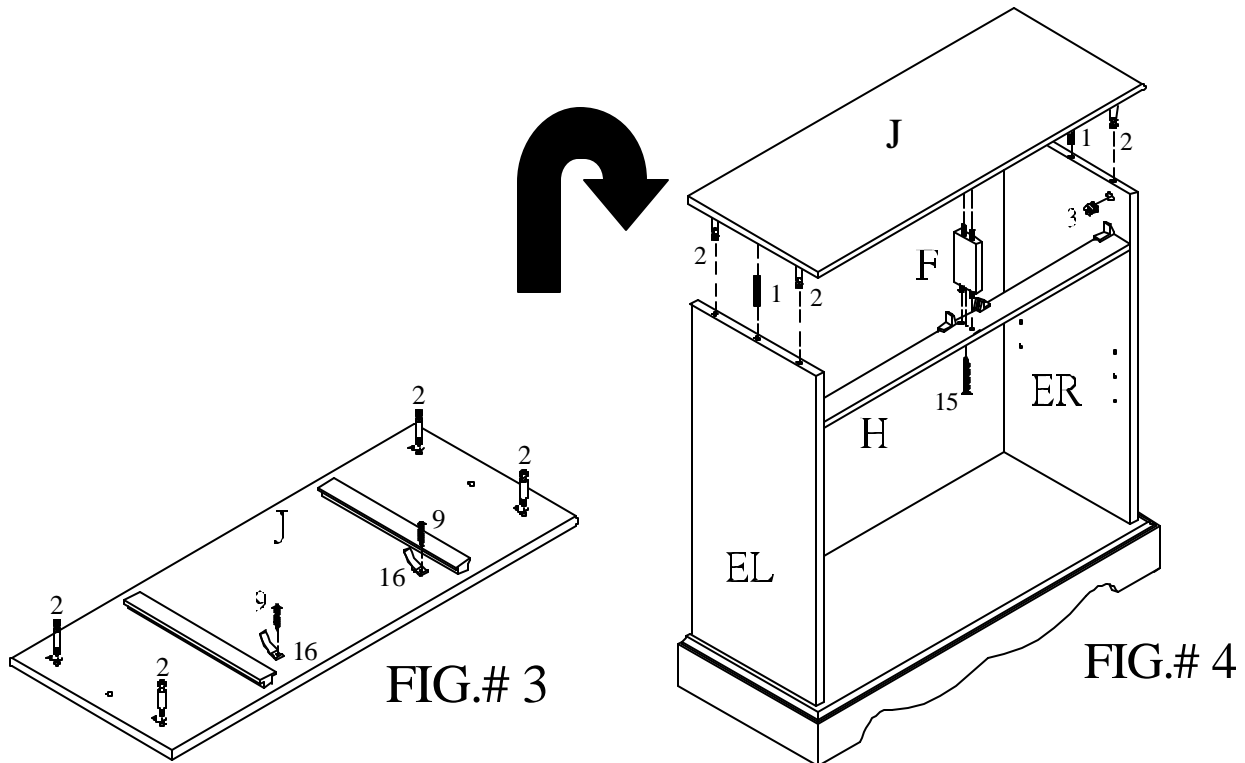
**STEP 4**

Please attach Taped Back Panel(K) to position then tighten to the **pilot holes on Top Panel (J) and both Side Panels (ER & EL)** by 20 pieces of Round Head Short Screw (12). **The TAPE should facing outward. See FIG#4A.**

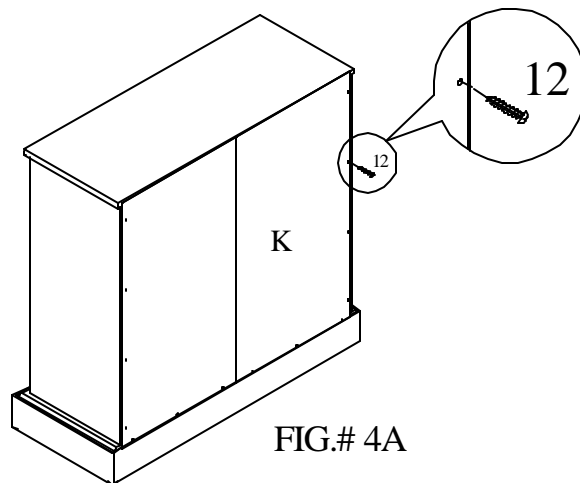
**STEP 5**

Please insert Short Wood Screw (6) through Glass Holder (11) to tighten it to both Door Frame (LL/LR).

See FIG#5

Please insert Wood Screw (5) through the hole on pre-assembled hinge on both Door Frames (LL/LR) to tighten to pilot holes on **inner side of** both Side Panels (ER & EL). **See FIG#6.**

Please insert Small Phillip Bolt (8) through both Door Frames (LL/LR) to tighten Door Knob (7) on the doors. **See FIG#6.**

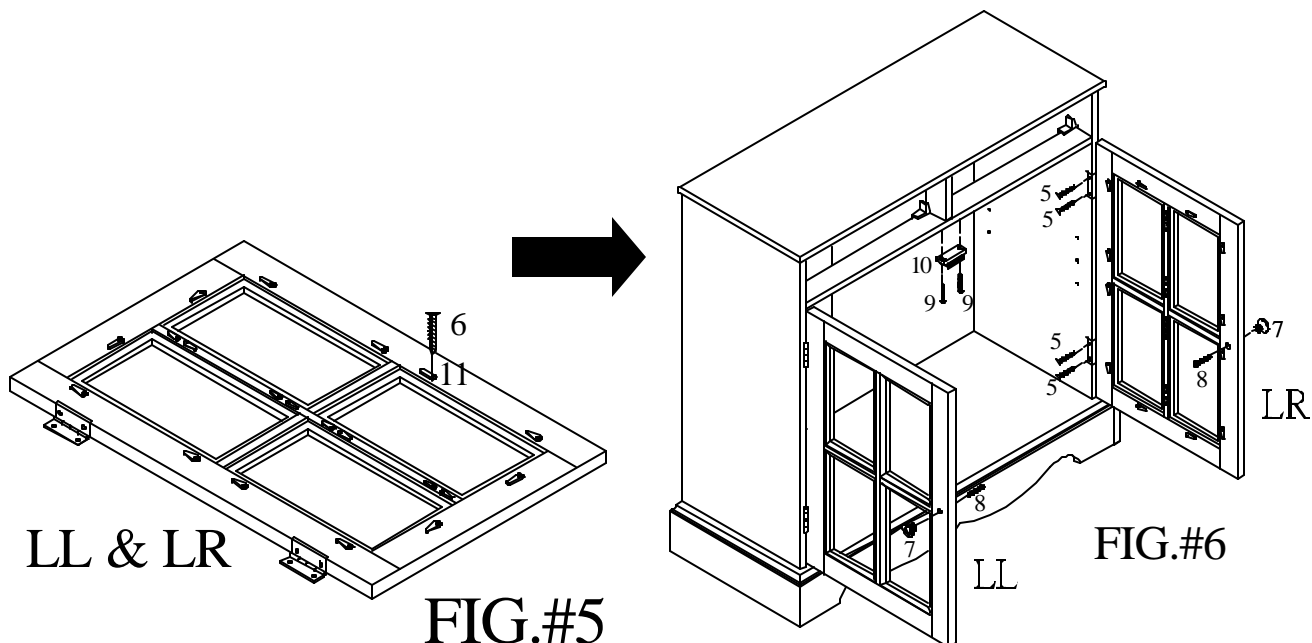

STEP 6

Please insert Wood Screw (9) through holes on Magnet (10) to tighten it to bottom side of Front Rail (H). See FIG#6
 Please insert Shelf Support (17) to inner side of both side panels and then put Shelf Panel(N) onto it.
 Please insert Door Glass (M) to both Door Frames (LL/LR),
 and then twist the Glass Holder (11) to secure it. See FIG#7
 Slide drawers into position of the unit.

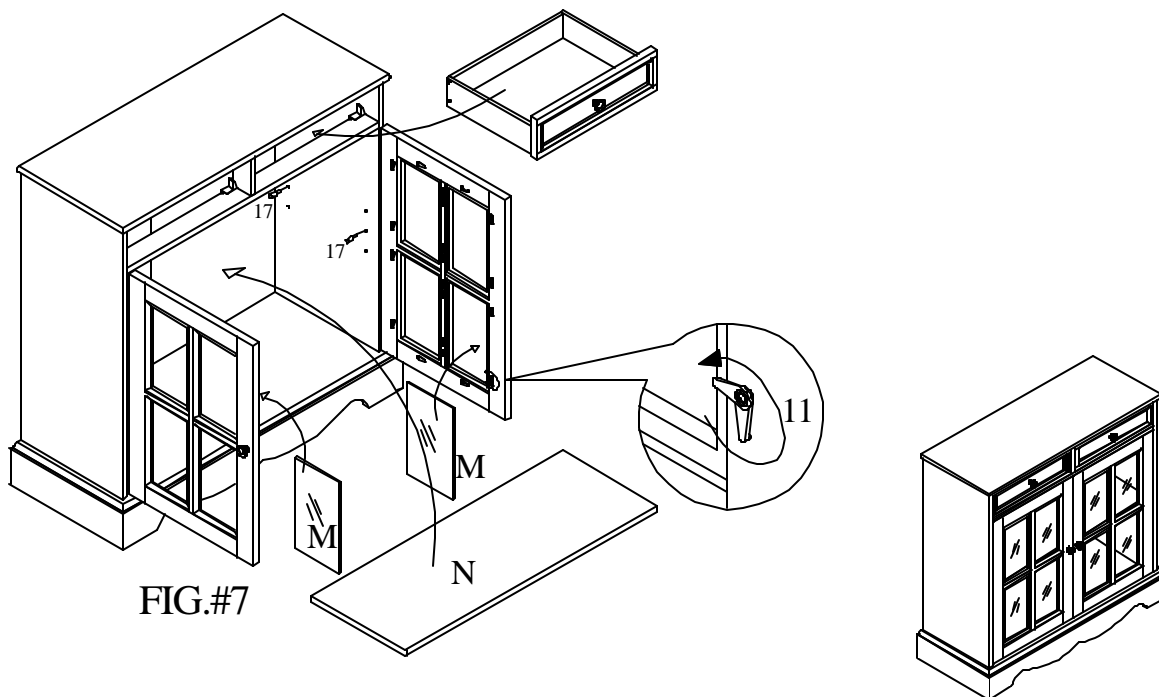

YOUR BEAUTIFUL 2-DRAWER/2-DOOR
 MEDIUM OAK FINISH BUFFET
 IS FINISHED AND READY TO USE.



SOUTHERN ENTERPRISES, INC
 P.O. Box 59996 Dallas, Texas

THIS PRODUCT IS NOT INTENDED FOR COMMERCIAL USE

