











SOUTHERN ENTERPRISES INC.

NOTE.... This product has been engineered for easy assembly and constructed for durability. Please take time to read and follow assembly instructions.

5PC "DOUBLE APPLE" DINETTE SET

STYLE NO. DN1447

HARDWARE LIST

1  Cross Bar 4 PCS	2  Short Screw 8PCS	3  Long Bolt 8PCS	4  Short Bolt 16PCS	5  Medium Bolt 8PCS
6  Rubber Cap 16PCS	7  Allen Wrench 1 Pc	8  Glide Cap 4PCS	9  Long Screw 16PCS	10  Glass Support 4PCS

Please count, identify and compare parts and hardware list to be sure all parts are present. It may help to divide parts and label them to correspond with part list. Extra hardware may be included. If any items are missing, please contact our parts/service department at (800) 633-5096 or in Dallas (972) 869-0111/ 9am – 4pm Mon-Fri Central time. Missing or damaged hardware and/ or parts will be replaced free of charge. **WE DO NOT SELL PARTS. WE DO NOT RECOMMEND MODIFYING PRODUCT (S) AND WE ARE NOT RESPONSIBLE FOR ANY DAMAGES DUE TO PRODUCT MODIFICATION (S).** If this product has not been purchased from our retail affiliates (within 9 months), we are under no obligation to provide parts or replacement merchandise. **WE WILL SHIP PARTS IF AVAILABLE. THIS IS NOT A WARRANTY.**

Parts will not be available for items arriving fully assembled.

Style No. DN1447

PARTS REPLACEMENT FORM

Customer Name _____

PARTS LETTER	PARTS DESCRIPTION	QUANTITY NEEDED
-----------------	----------------------	--------------------

Street, City, State, Zip _____





SOUTHERN ENTERPRISES INC.
P.O. Box 59996 Dallas, Texas 75229

Please indicate where you purchased this item.
Store/ website/ catalog _____

Please indicate color/ size/ style number.
_____/_____/_____

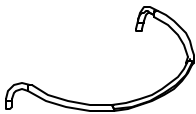
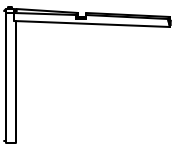
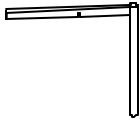
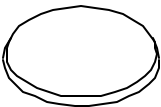
PARTS LIST

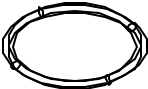
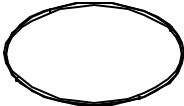
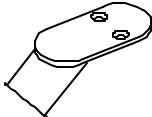
A. Chair Back 4PCS 	B. Leg Support Bar 4PCS 	C. Bottom Cut Chair Leg 4PCS 
D. Top Cut Chair Leg 4PCS 	E. Wood Seat 4 PCS 	F. Table Leg 4 PCS 
G. Center Ring 2PCS 	H. Wood Table Top 1PC 	J. Table Leg Fastener 4PCS 

ASSEMBLY INSTRUCTIONS

TABLE

STEP 1

Insert Glide Cap (8) in bottom end of Table Legs(F).

Insert Glass Support (10) in each slot on Glide Cap (8) .

STEP 2

Using Medium Bolt (5) and Cross Bar (1) to assemble Center Ring (G) to Table Legs(F) at HIGHER position.

Be sure each leg has one Cross Bar (1) in between of Center Ring (G) and Table Legs(F) . They will form as 2X's.

Caution: tighten screws loosely.

Tighten completely only when lower ring is complete.

STEP 3

Repeat Step 2 to assemble Center Ring (G) to Table Legs (F) at

LOWER position .Tighten Medium Bolt (5) to secure when both Center Ring (G) are assembled into position.

Please insert one Table Leg Fastener (J) into top end of each Table Legs(F).

Now above parts become a BASE.

STEP 4

Please upside down the Wood Table Top (H) on a soft surface.

Please upside down the BASE on the back side of Wood Table Top (H), and then insert Short Screws (2) through holes on round shape plate on end of Table Leg Fastener(J) to assembled Table Leg Fastener(J) to pilot holes on back side of Wood Table Top (H)

CAUTION: DO NOT OVERTIGHTEN Short Screws (2)!

Or carefully measure 5.25 inches from outer edge of Wood Table Top (H) to outer edge of each Table Leg Fastener (J).

NOTE:BASE should be at center of table top.

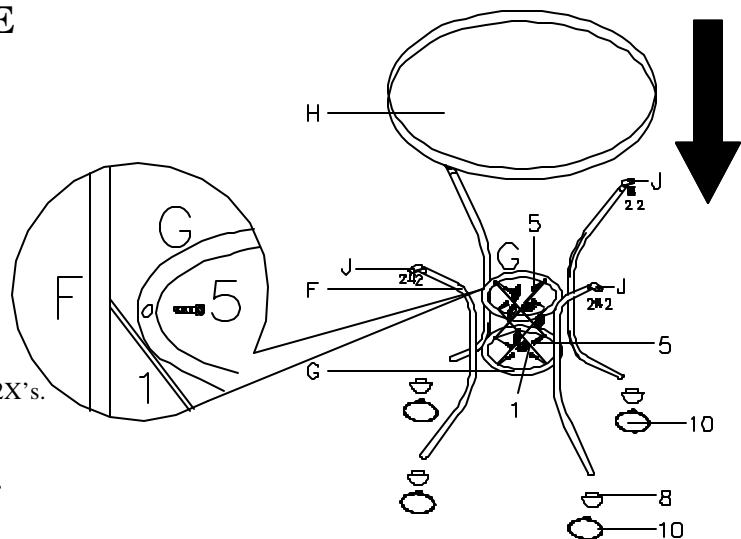

CHAIR

STEP 1

Using Wrench (7), screw Top Cut Chair Leg (D) to Chair Back (A) with Long Bolt(3).

STEP 2

Repeat step 1 for Bottom Cut Chair Leg (C). These two Cuts will form a BASE for the chair seat.

STEP 3

Using Wrench (7), screw Leg Support Bar (B) to all Chair legs (A), (C), (D) with Short Bolt (4).

STEP 4

Turn chair upside down, fasten Wood Seat (E) to Cross bar of Cut Chair Legs (C),(D) using Long Screws(9).

STEP 5

Insert Rubber Cap (6) into Chair Back (A) and Cut Chair Legs (C),(D) .

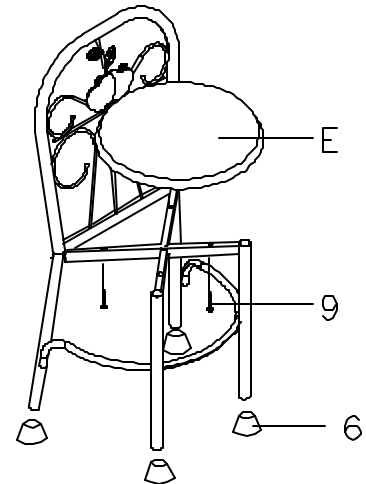
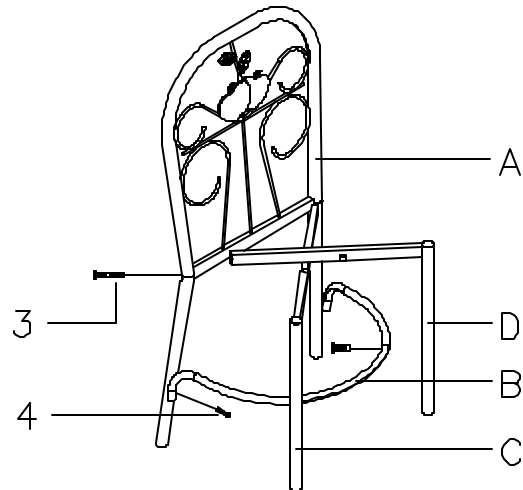

YOUR BEAUTIFUL 5PC "DOUBLE APPLE"
DINETTE SET IS FINISHED AND READY TO
USE .



SOUTHERN ENTERPRISES, INC

P.O. Box 59996 Dallas, Texas 75229

THIS PRODUCT IS NOT INTENDED FOR COMMERCIAL USE.