



SOUTHERN ENTERPRISES INC.



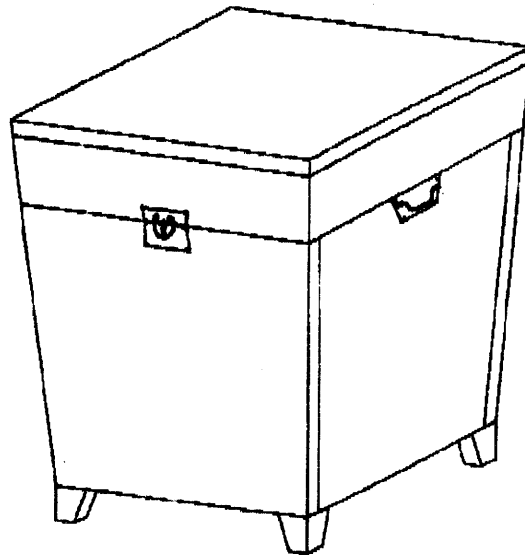

RELAX... If you can follow a few easy, step-by-step

directions in order. YOU CAN ASSEMBLE THIS ITEM.



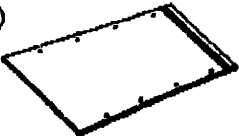
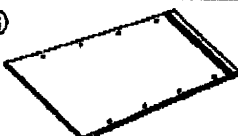

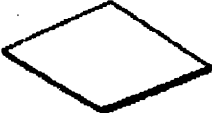



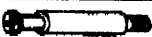

ASSEMBLY INSTRUCTION CK122500UT



Parts list

①  TOP-1PC	②  FRONT PANEL-1PC	③  BACK PANEL-1PC	④  SIDE PANEL-2PCS
⑤  BOTTOM PANEL-1PC	⑥  LEG-4PCS		

Hardware list

A	Cam-bolt		8PCS	G	SUPPORT		1PC
B	Cam-lock		8PCS	H	HANDLE-A		1PC
C	Flat Wrench		1PC	I	HANDLE-B		1PC
D	Dowel		8PCS	J	HANDLE		2PCS
E	Bolts		8PCS				
F	Screws		25PCS				

step 1

Put all parts on a soft surface to prevent scratches, place "H" on the 1, tight with "F", "C"

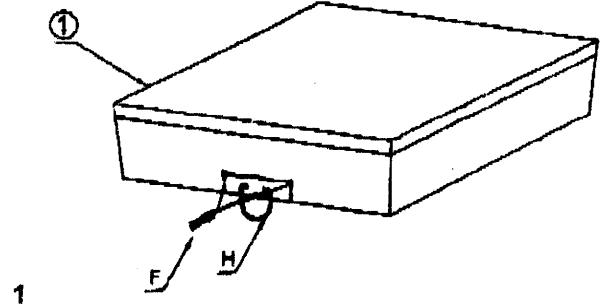

Place "I" on the 2, mount tight with "F", "C" as show

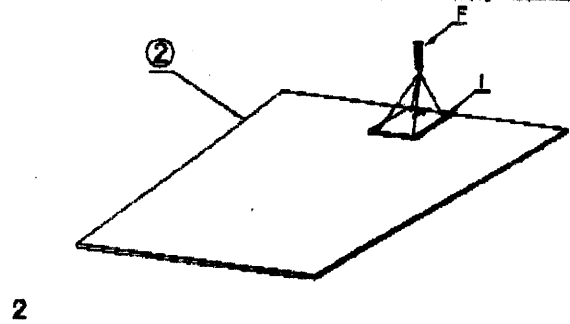

Turn 2, Mount tight "A" on the 2 with "C"

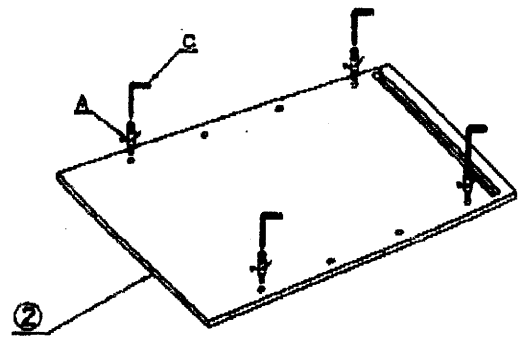

Place "J" on the 4, mount tight with "F", "C"

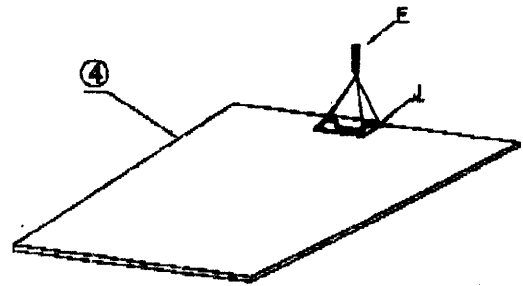

Mount tight "A" on the 3 with "C"

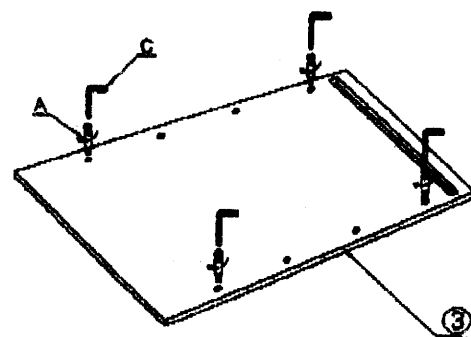

step 2

Put "D" on the 2,3 Correct 2,4by "A"
"C", slide 5 in to groove of panel 3,4
then put 2 screw "A" and tight thew

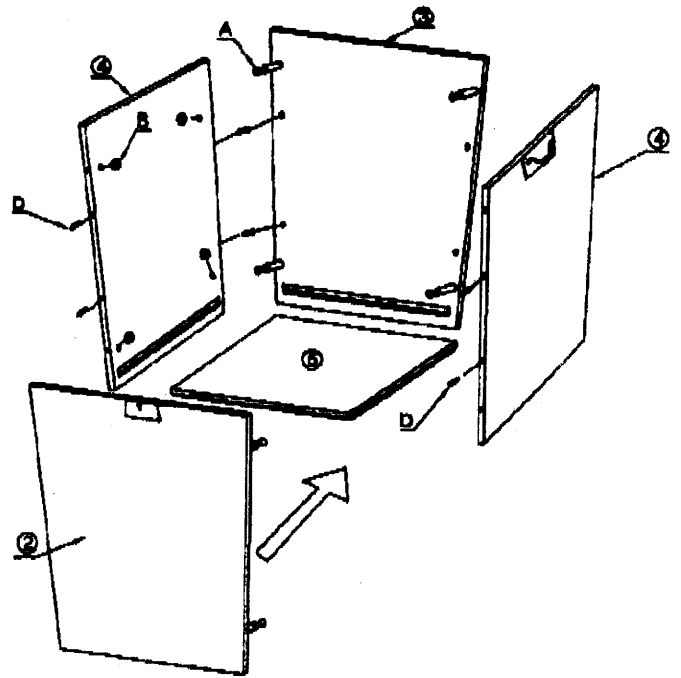

step 3

Turn trunk screws 6 on the bottow
of trunk by "E"

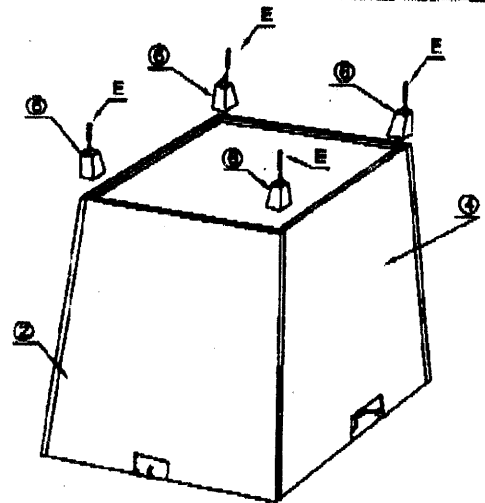

step 4

Councet 1 and trunk body with "F"

