

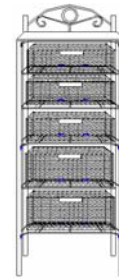

SOUTHERN ENTERPRISES INC.

NOTE... This product has been engineered for easy assembly and constructed for durability







Now please take time to read through and follow assembly instructions.





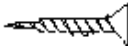

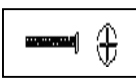
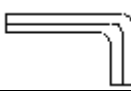
Sh 1

5-DRAWER WICKER STORAGE UNIT
 LOT NO.781-9400 STYLE NO.BE8999

HARDWARE LIST

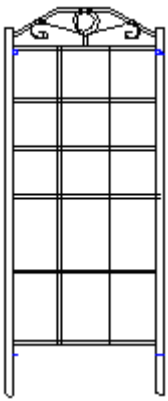
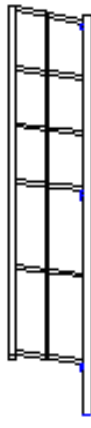
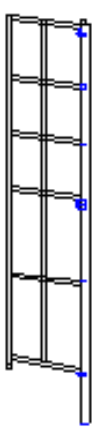
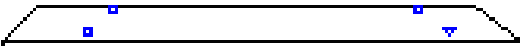
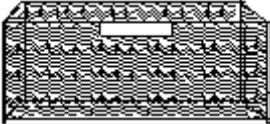
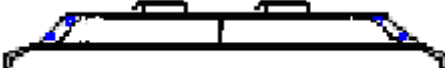
A.ALLEN BOLT 4PCS  	B.WOOD SCREW 4PCS  	C.BOTTOM CAP 4PCS 	D.1/2" PHILLIP BOLT 20PCS 	E. ALLEN WRENCH 1PC 	F. TOP END CAP 4PCS 
---	--	--	--	--	--

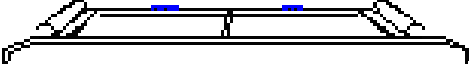
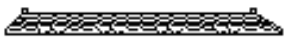
PARTS LIST

1.BACK PANEL 1PC 	2.SIDE PANEL 2PCS   RIGHT LEFT	3.TOP WOOD PANEL 1PC 	6.LARGE WICKER BASKET 2PCS 
		4.TOP METAL FRAME 1PC 	7.SMALL WICKER BASKET 3PCS 
		5.SHELF METAL FRAME W/ HOOK 2PCS 	8.WICKER BASKET BOTTOM PANEL 5PCS 
9.SHELF METAL FRAME NO HOOK 3PCS 			

Please count, identify and compare parts and hardware list to be sure all parts are present. You will also need a Phillips screwdriver, which is not included. Extra hardware may be included. If any items are missing, please contact our parts/ service department at (800) 633-5096 or in Dallas (972) 869-0111/ 9am-4pm Mon-Fri central time. Missing or damaged hardware and/ or parts will be replaced free of charge. WE DO NOT SELL PARTS. WE DO NOT RECOMMEND MODIFYING PRODUCT(S) AND WE ARE NOT REPOSIBLE FOR ANY DAMAGES DUE TO PRODUCT MODIFICATION(S).

Style No.BE8999

PARTS REPLACEMENT FORM

Customer Name _____

PARTS LETTER

PARTS DESCRIPTION

QUANTITY NEEDED

Street, City, State, Zip _____



SOUTHERN ENTERPRISES INC.
 P.O. Box 59996 Dallas, Texas 75229

Please indicate where you purchased this item.
 Store/website/catalog _____

Please indicate color/ size/ style number.
 _____ / _____ / _____

ASSEMBLY INSTRUCTION

STEP 1. SNAP BOTTOM CAP (C) TO THE BOTTOM OF BACK PANEL (1) AND BOTTOM SIDE PANELS (2). ATTACH BOTH SIDE PANELS (2) TO BACK PANEL (1) BY USING 4 PCS SHORT ALLEN BOLT (A). SNAP TOP END CAP (F) TO THE TOP OF SEMI-RACK.

STEP 2. ATTACH SHELF METAL FRAME NO HOOK (9) TO BACK PANEL (1) AND BOTH SIDE PANELS (2).

STEP 3. ATTACH TOP METAL FRAME (4) TO THE TOP OF BOTH SIDE PANELS (2), INSERT THE HOOK OF TOP METAL FRAME (4) TO SIDE PANEL (2). THEN HANG ON 2 SHELF METAL FRAME W/ HOOK (5) TO BACK PANEL AND INSERT THE HOOKS TO BOTH SIDE PANELS (2).

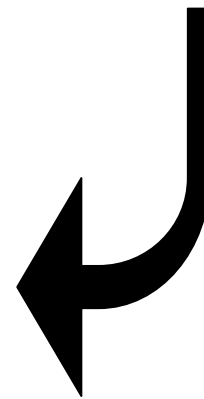
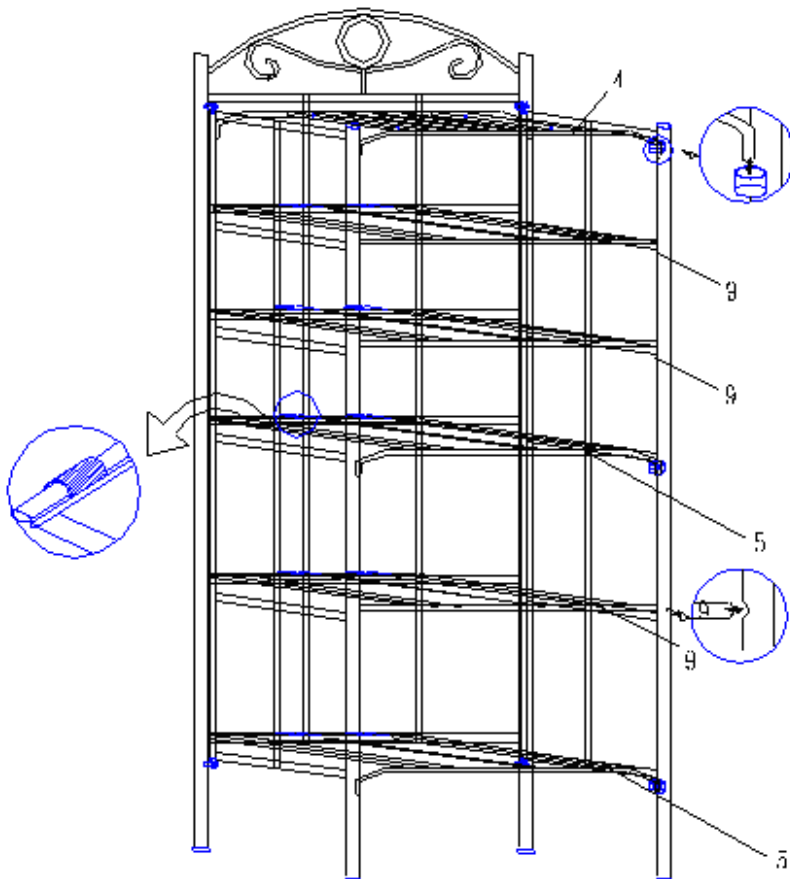
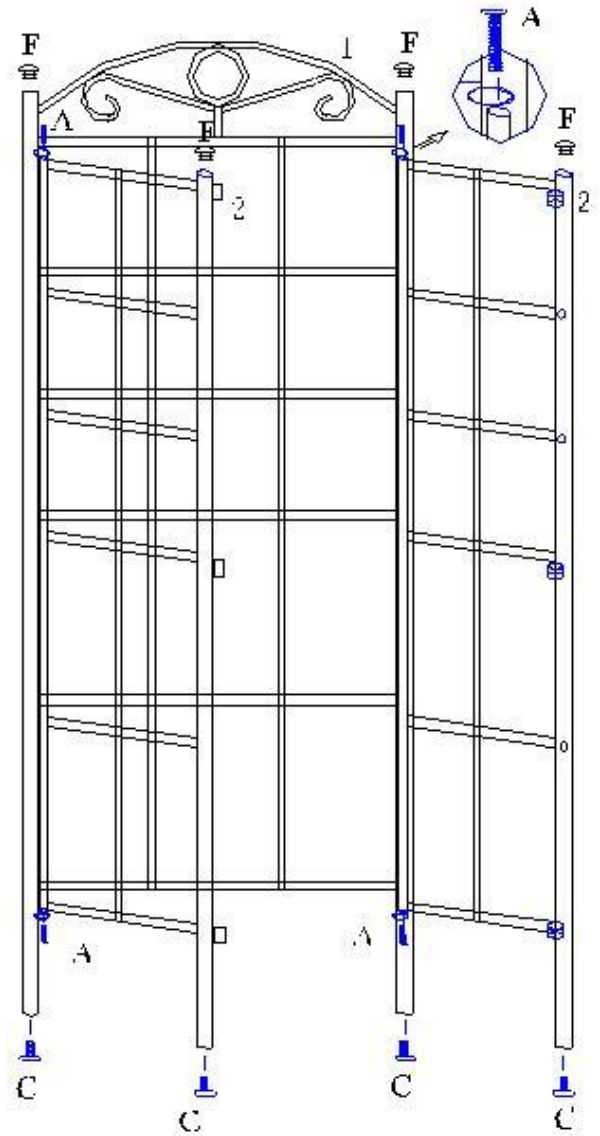

SOUTHERN ENTERPRISES, INC
 P.O. Box 59996 Dallas, Texas 75229

ASSEMBLY INSTRUCTION

STEP 4. SCREW WICKER BASKET BOTTOM PANEL AND LARGE/ SMALL WICKER BASKET (6)(7) W/ LONG ALLEN BOLT (D).

STEP 5. SCREW TOP WOOD PANEL (3) AND TOP METAL FRAME W/ WOOD SCREW (B). PUT ON ALL WICKER BASKET

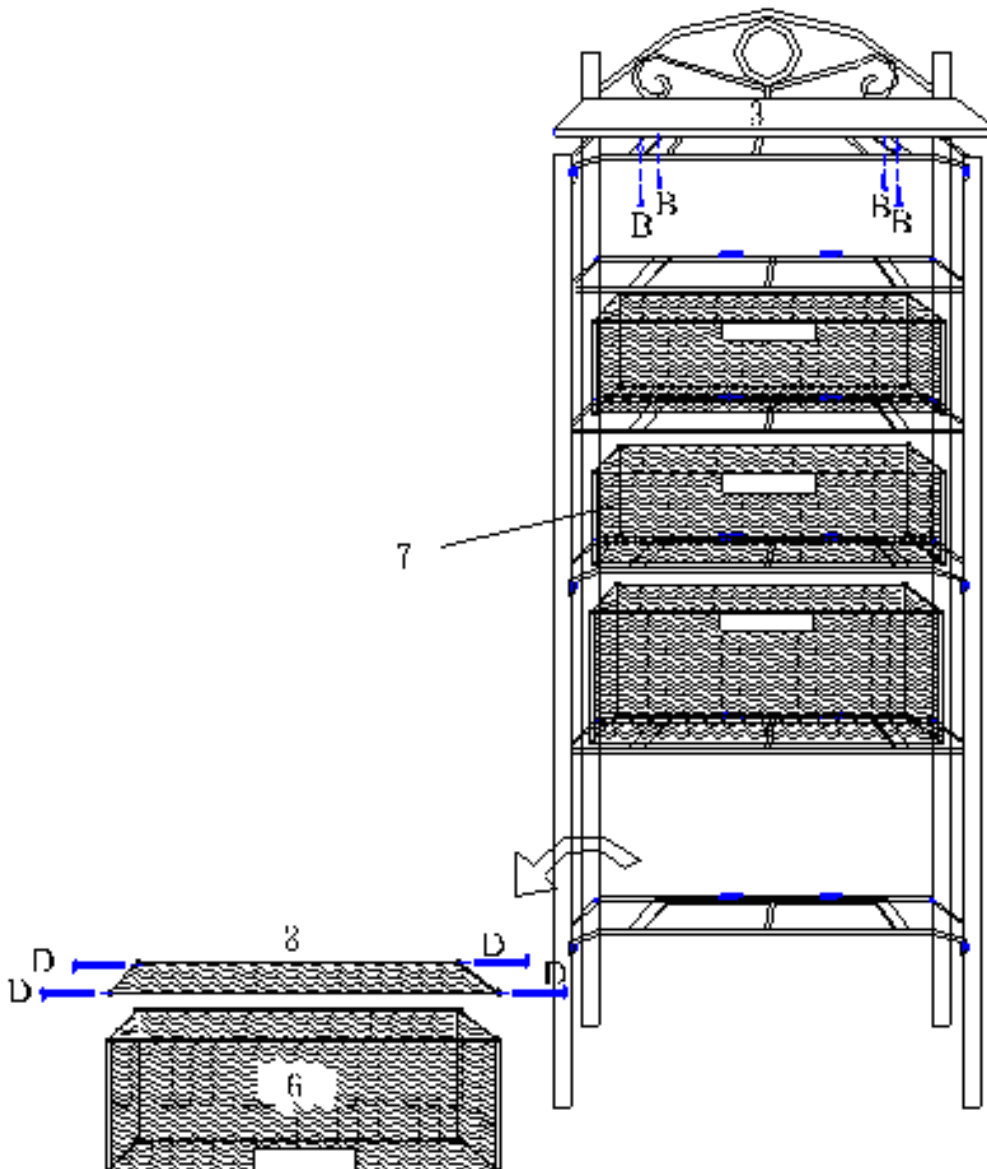

YOUR BEAUTIFUL 5-DRAWER WICKER STORAGE UNIT IS FINISHED AND READY TO USE.

THIS PRODUCT IS NOT INTENDED FOR COMMERCIAL USE.



SOUTHERN ENTERPRISES, INC

P.O. Box 59996 Dallas, Texas 75229