





STYLE NO: BE868300TX  
BAMBOO STORAGE CABINET

**SOUTHERN ENTERPRISES INC.**

RELAX...If you can follow a few easy, step-by-step directions in order .YOU CAN ASSEMBLE THIS ITEM.

**PLEASE FIND HARDWARE IN RED POLYBAG BEFORE DISCARDING THE PACKING MATERIALS.**

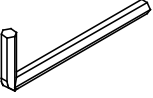
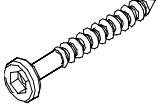
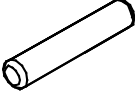
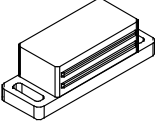
**HARDWARE LIST**

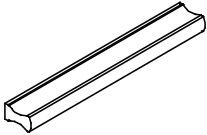
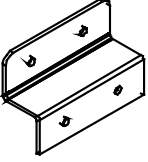
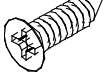
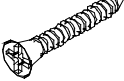
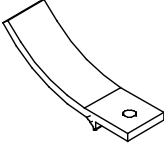
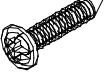
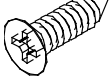
(1) Allen Wrench X 1 PC 	(2) Bolt X 10 PCS φ3/16"x2 1/4" 	(3) Dowel X 10PCS 	(4) Magnet X 1 PC 	(5) Bolt X 6 PCS φ1/4"x3/4" 	(6) Handle X 3 PCS 
(7) Hinge X 4 PCS 	(8) Screw X 16 PCS φ3/16"x1/2" 	(9) Screw X10PCS φ5/16"x1" 	(10) Drawer Stopper X 1 PC 	(11) Screw X 2 PCS φ3/16"x5/18" 	(12) Screw X 1PC φ1/4"x1/2" 

**PARTS LIST**

(A) Front Upper Cross Bar X 1 PC 	(B) Front Lower Cross Bar X 1 PC 	(C) Back Lower Cross Bar X 1 PC 	(D) Left Side Facing Frame X 1 PC 	(E) Right Side Facing Frame X 1 PC 
(F) Back Panel X 2 PCS 	(G) Back Vertical Cross Bar X 1 PC 	(H) Top Panel X 1 PC 	(I) Left Side Facing Door X 1 PC 	
(J) Right Side Facing Door X 1 PC 	(K)Drawer Side X2PCS 	(L) Drawer Back X 1 PC 	(M) Drawer Bottom X 1 PC 	
(N)Drawer Front X 1 PC 	(O) Middle Shelf X 1 PC 	(P) Bottom Panel X 1 PC 	(Q) Slot X 1 PC 	

FIGURE 1

Attach the Slot (Q) to the Front Upper Cross Bar (A) by using Screws (9). Put the Left Side Facing Frame (D) side-standing, attach the Front Upper Cross Bar (A), Front Lower Cross Bar (B) and the Back Lower Cross Bar (C) to it by using Bolts(2) and Dowels (3).

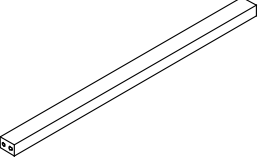
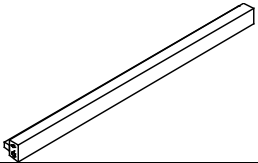
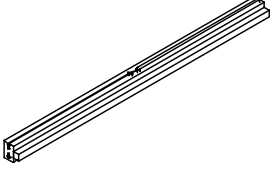
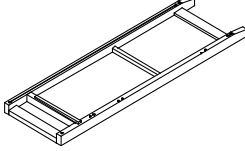
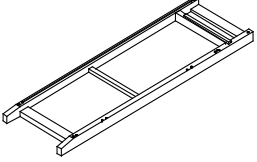
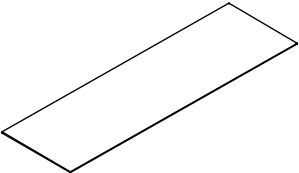
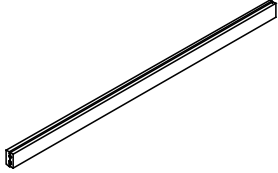
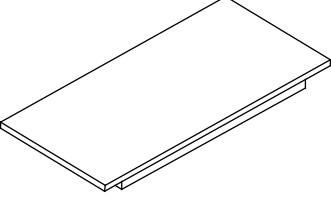
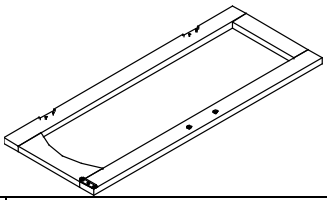
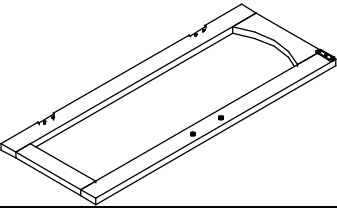
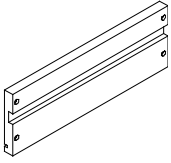
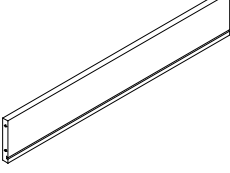
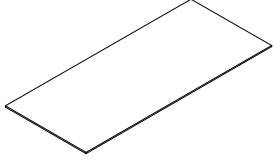
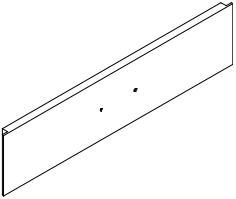
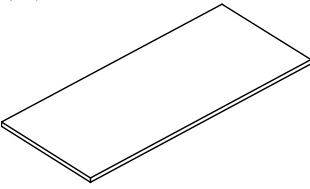
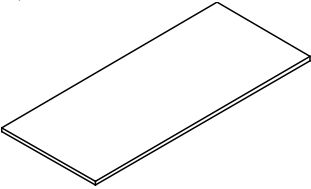
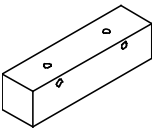
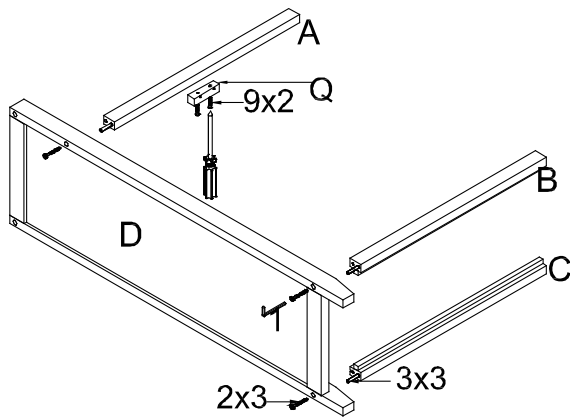

FIGURE 2

Attach the Magnet (4) to the Front Upper Cross Bar by using Screws (11). Then attach the Right Side Facing Frame (E) to the Front Upper Cross Bar (A), Front Lower Cross Bar (B) and the Back Lower Cross Bar (C) to it by using Bolts(2) and Dowels (3).

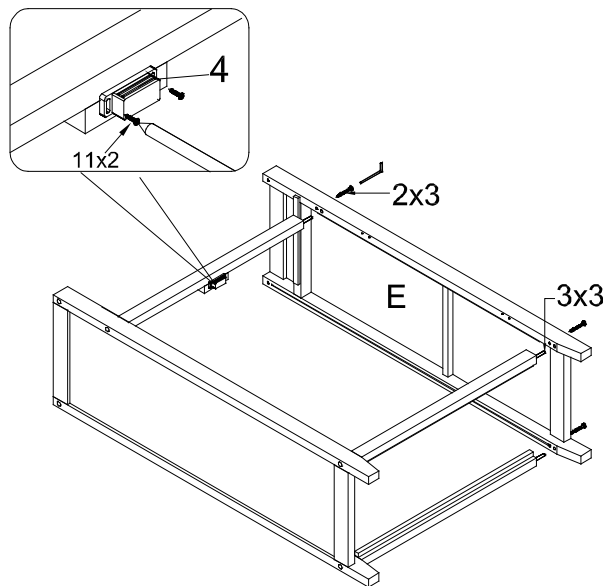

FIGURE 3

Connect the Back Vertical Cross Bar (G) with the Back Lower Cross Bar (C) by using Dowels (3). Insert the Back Panels (F) into the grooves between the Back Vertical Cross Bar(G) and the Left/Right Side Facing Frames (D/E).

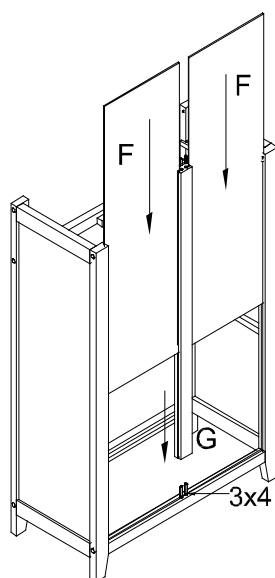

FIGURE 4

Attach the Drawer Stopper (10) to the front cross bar that on the Top Panel (H) by using Screws (12), then put the Top Panel (H) on top of the assembled unit and tighten it by using Bolts (2).

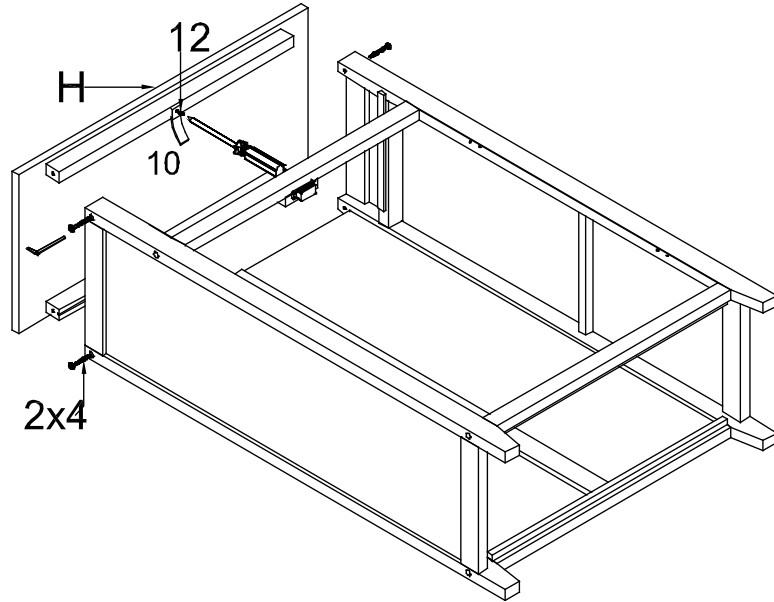

FIGURE 5

Attach the hinges (7) to the predrilled holes on the Left/Right Side Facing Door (I/J) by using Screws (8), and attach the Handles (6) to the predrilled holes on the Left/Right Side Facing Door (I/J) by using Bolts (5).

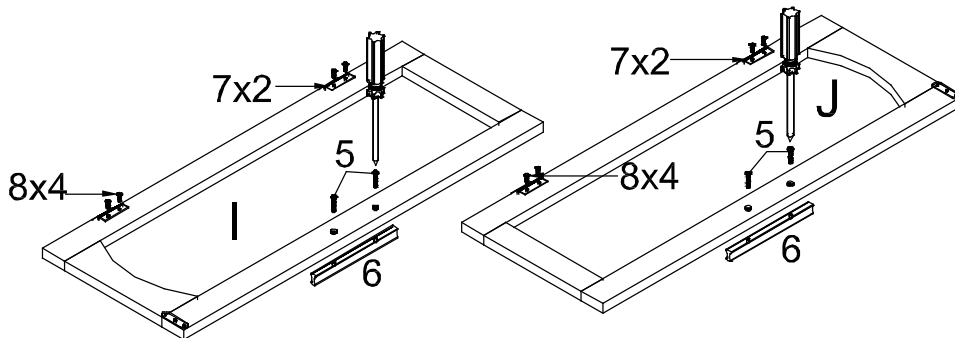

FIGURE 6

Attach the Left/Right Side Facing Door (I/J) to the well assembled unit by using Screws (8).

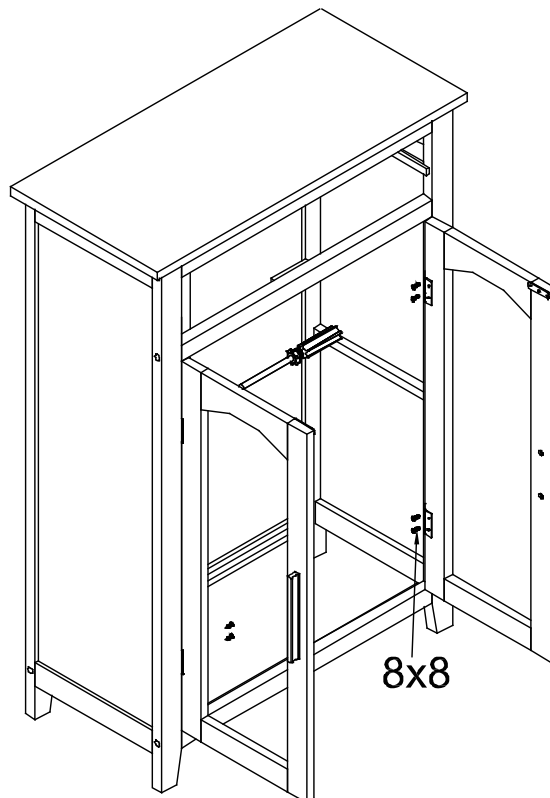

FIGURE 7

Attach the Drawer Sides (K) to the Drawer Front (N) by using Screws (9), then insert the Drawer Bottom (M) into the grooves that between the 2 Drawer Sides (K).

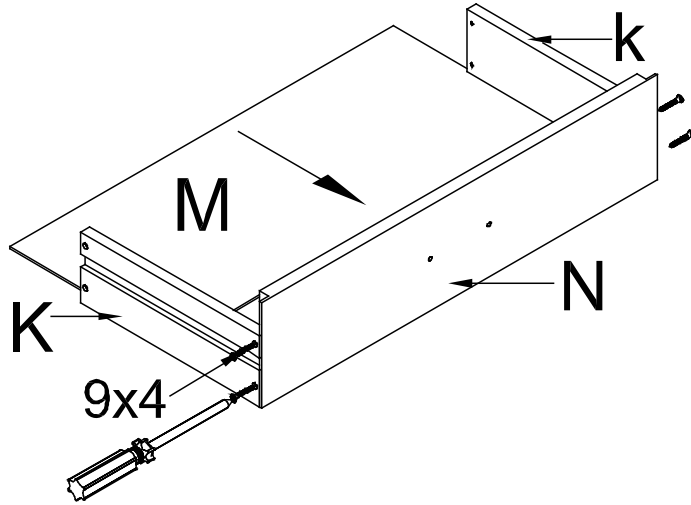

FIGURE 8

Attach the Handles (6) to the Drawer Front (N) by using Bolts (5), then attach the Drawer Back (L) to the Drawer Sides (K) by using Screws (9).

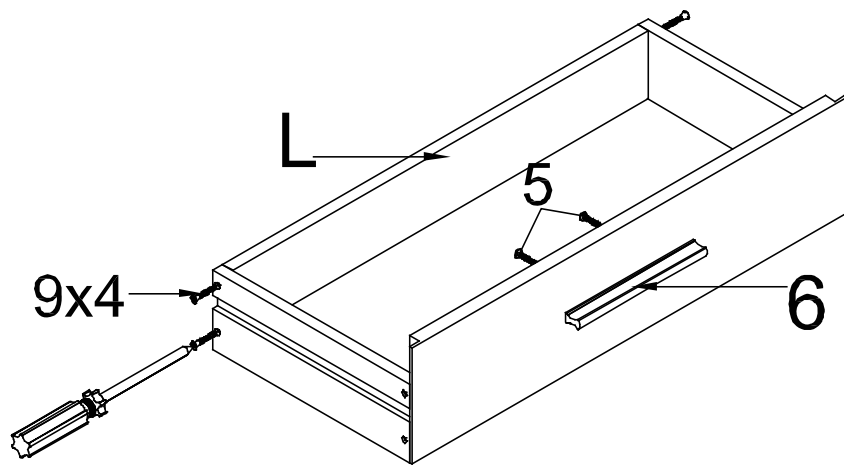
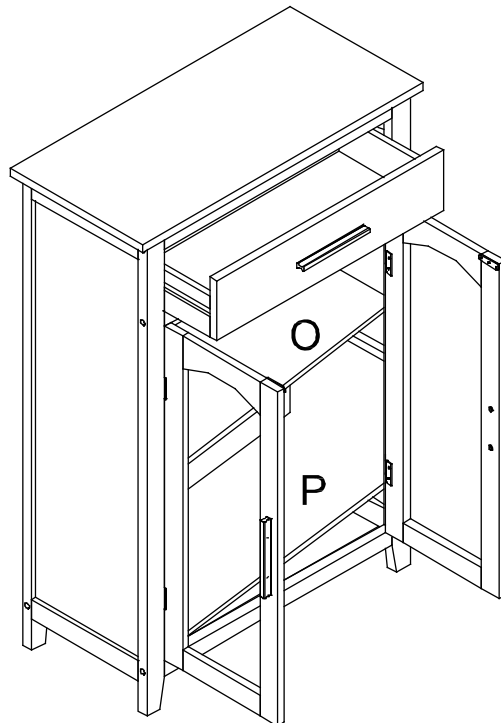

FIGURE 9

Finally, put the drawer , the Shelf (O) and the Bottom Panel (P) inside the assembled unit.



**YOUR "BAMBOO STORAGE CABINET" IS FINISHED AND READY TO USE**

**"We will ship parts if available" "This is not a warranty"**

Please count, identify and compare parts and hardware list to be sure all parts are present. It may help to divide parts and label them to correspond with part list. Extra hardware may be included. If any items are missing, please contact our parts/service department at (800) 633-5096 or in Dallas (972) 869-0111/ 9am – 4pm Mon-Fri Central time. Missing or damaged hardware and/ or parts will be replaced free of charge. WE DO NOT SELL PARTS. WE DO NOT RECOMMEND MODIFYING PRODUCT(S) AND WE ARE NOT RESPONSIBLE FOR ANY DAMAGES DUE TO PRODUCT MODIFICATION(S). If this product has not been purchased from our retail affiliates (within 9 months), we are under no obligation to provide parts or replacement merchandise. Parts will not be available for items arriving fully assembled.

<b>PARTS REPLACEMENT FORM</b>			
STYLE NO: <b>BE868300TX</b>			
Customer Name	PARTS LETTER	PART DESCRIPTION	QUANTITY NEEDED
Street, City, State, Zip			
Phone#			
		Please indicate where you purchased this item. Store/website/catalog _____ / _____ / _____	
SOUTHERN ENTERPRISES INC. P.O. Box 59996 Dallas, Texas 75229		Please indicate color/size/style number _____ / _____ / _____	