



SOUTHERN ENTERPRISES INC.

RELAX...If you can follow a few easy, step-by-step directions in order .YOU CAN ASSEMBLE THIS ITEM.

PLEASE FIND HARDWARE IN RED POLYBAG BEFORE DISCARDING THE PACKING MATERIALS.

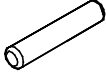

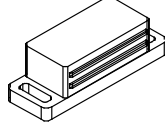
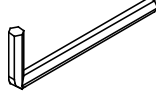
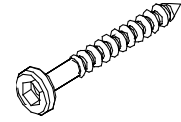
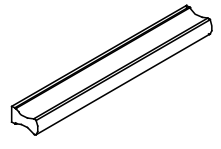
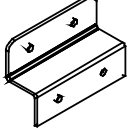
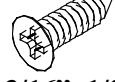
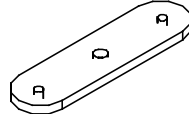
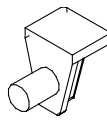
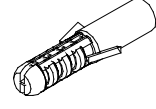
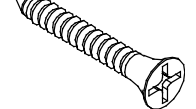
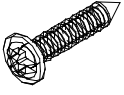
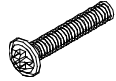
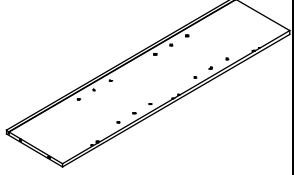
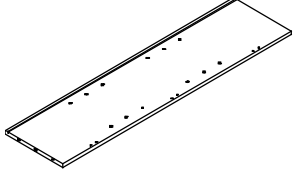
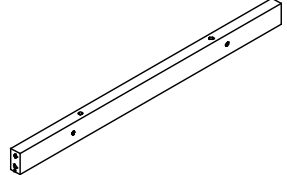
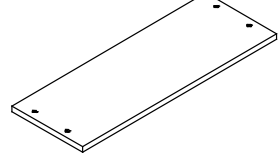
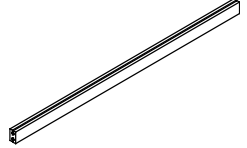
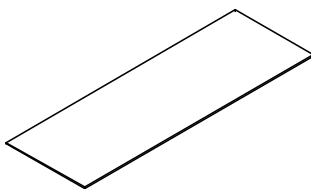
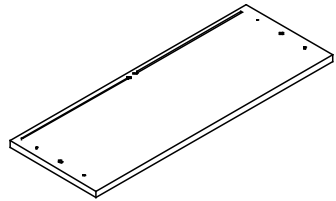
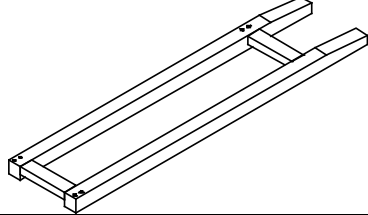
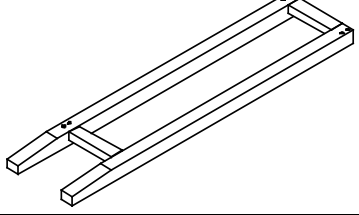
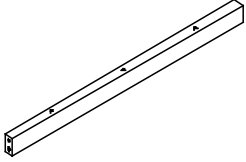
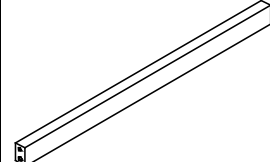
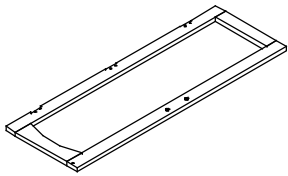
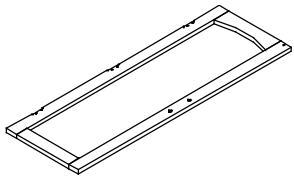
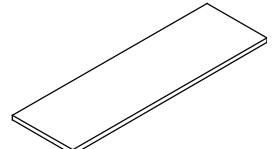
HARDWARE LIST					
(1) Dowel X 18 PCS 	(2) Screw X 14 PCS  φ5/16"x1 1/4"	(3)Magnet to Top Panel X 1 PC 	(4) Allen Wrench X 1 PC 	(5) Bolt X 6 PCS  φ3/16"x2 1/4"	(6) Handle X 2 PCS 
(7) HingeX 6 PCS 	(8)Screw X 26 PCS  φ3/16"x1/2"	(9) Magnet to Door X 2 SETS 	(10) Shelf Holder X 8 PCS 	(11) Anchor X 2 PCS 	(12) Screw X 2 PCS  φ5/16"x1 1/2"
(13) Screw X 2 PCS  φ3/16"x5/8"	(14)Bolt X 4 PCS  φ1/4"x3/4"				
PARTS LIST					
(A) Upper Left Side Panel X 1 PC 	(B) Upper Right Side Panel X 1 PC 	(C) Back Upper Cross Bar X 1 PC 	(D) Top Panel X 1 PC 	(E) Vertical Cross Bar X 1 PC 	
(F) Back Panel X 2 PCS 	(G) Middle Partition Panel X 1 PC 	(H) Base Left Side Frame X 1 PC 	(I) Base Right Side Frame X 1 PC 		
(J) Middle Cross Bar X 2 PCS 	(K) Back Lower Cross Bar X 1 PC 	(L) Left Door X 1 PC 	(M) Right Door X 1 PC 	(N) Shelf X 2 PCS 	

FIGURE 1

Connect the Back Upper Cross Bar (C) with the Upper Left Side Panel (A) and the Upper Right Side Pane (B) by using Dowels (1).

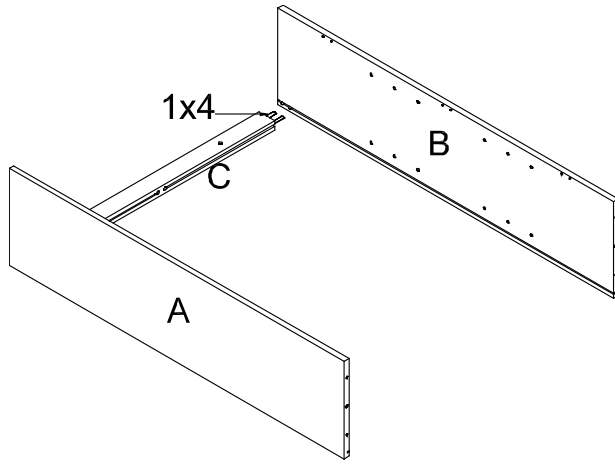


FIGURE 2

Attach the Magnet (C) to the Top Panel (D) by using Screws (n). Then use The Dowels (1) and the screws (2) to connect the Top Panel (D) with the assembled frame that finished at Figure 2.

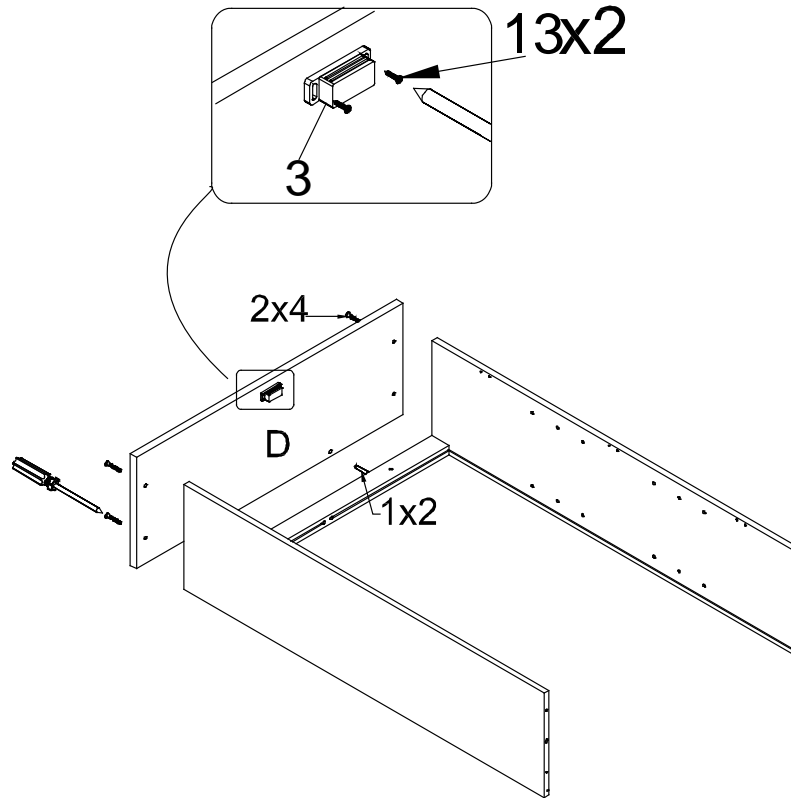


FIGURE 3

Attach the Vertical Cross Bar (E) to the Back Upper Cross Bar (3) by using Dowels (1). Then insert the Back Panels (F) into the grooves in the Upper Left/Right Side Panel (A/B).

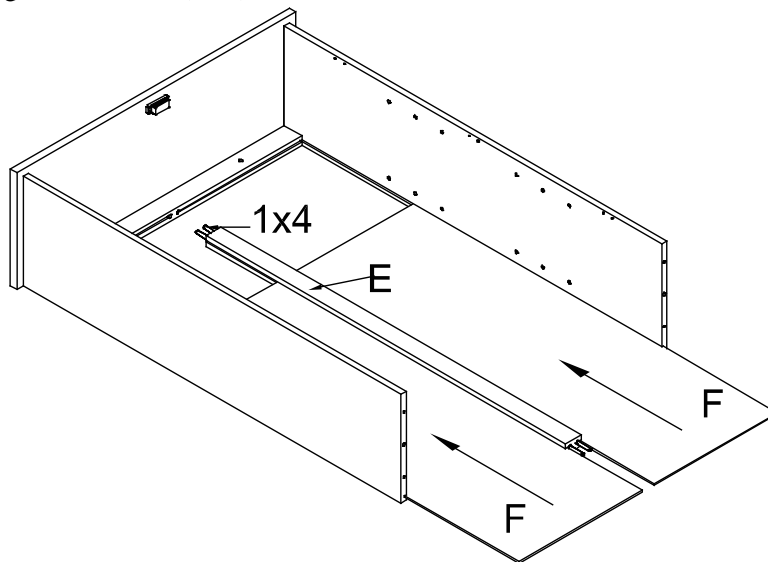


FIGURE 4

Use Dowels (1) and Screws (2) to connect the Middle Partition Board (G) with the assembled frame that finished at Figure 3.

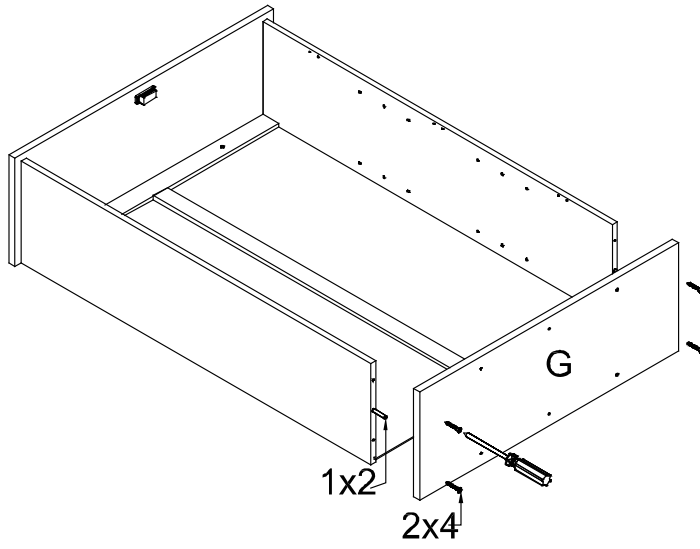


FIGURE 5

Attach the Middle Cross Bars (J) and the Back Lower Cross Bar (K) to the Base Left/Right Side Frame (H/I) by using Dowels (1) and Bolts (5).

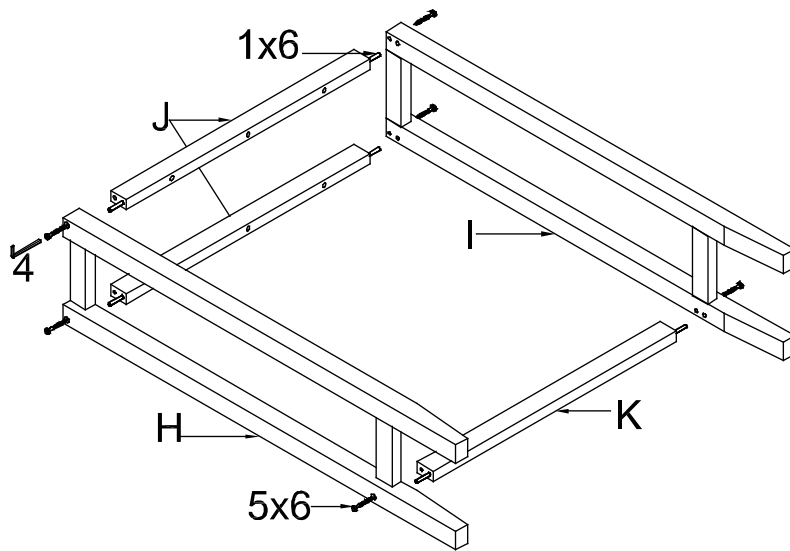


FIGURE 6

Connect the well assembled upper frame with lower frame by using Screws (2).

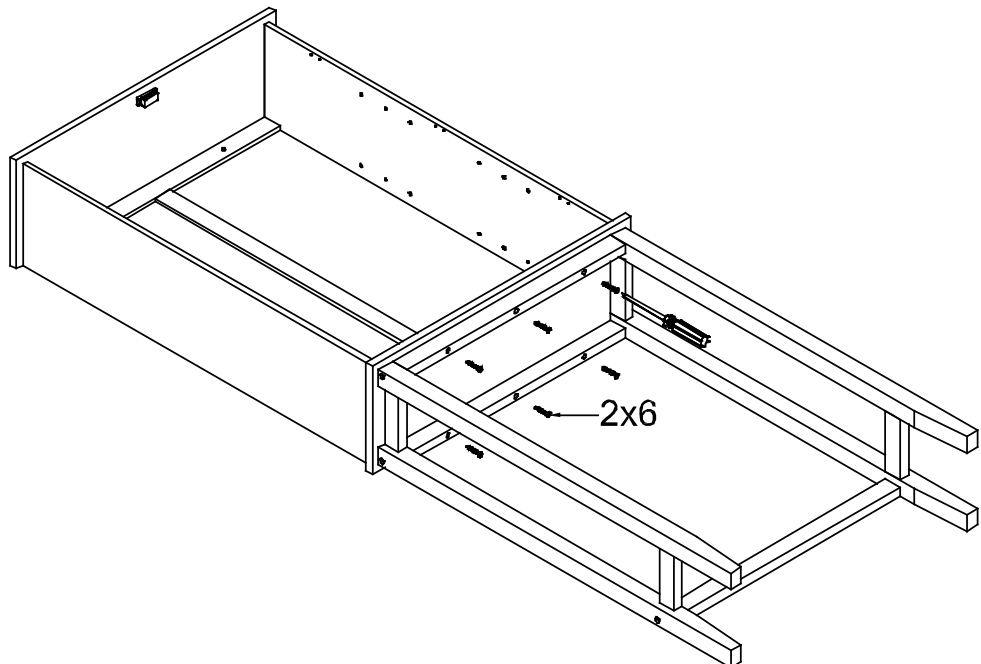


FIGURE 7

Put the Hinges (7) and Magnets (9) on the Left/Right Door Frames(L/M) at the predrilled holes and tighten them with Screws (8) .
Attach the Handles (6) to the Left/Right Door Frames(L/M) at the predrilled holes and tighten them with Bolts (14).

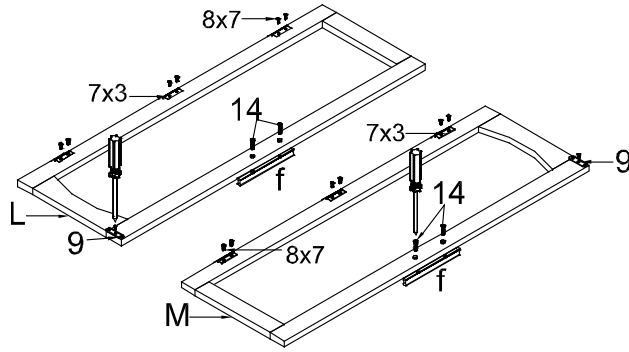


FIGURE 8

Attach the Left/Right Door Frames(L/M) to the Upper Left Side Panel (A) and the Upper Right Side Pane (B) by using screws (8).Then insert the Shelf holders (10) to the predrilled holes that you want.

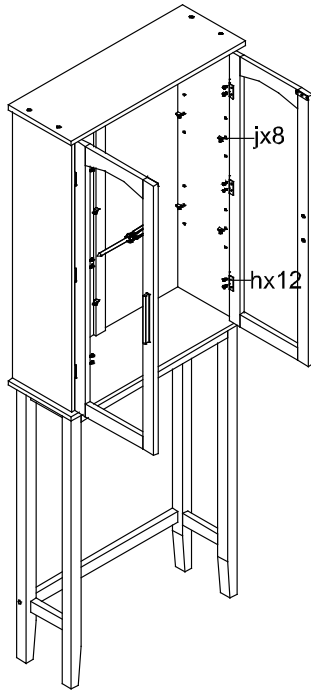
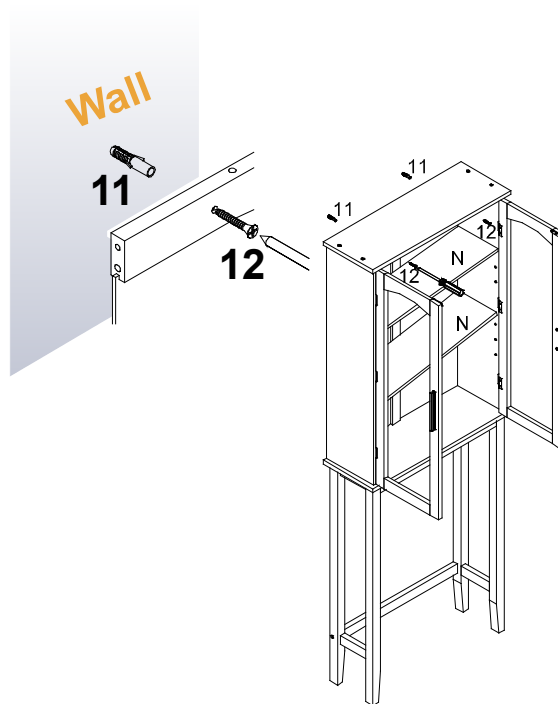



FIGURE 9

Put the Shelves (N) onto the Shelf Holders (10). Insert Wall Anchors (11) into the wall first, locking up the unit into the wall with Screws (12), and finally check if the unit is attached on the wall firmly.



YOUR “BAMBO SPACESAVER ” IS FINISHED AND READY TO USE
“We will ship parts if available” “This is not a warranty”

Please count, identify and compare parts and hardware list to be sure all parts are present. It may help to divide parts and label them to correspond with part list. Extra hardware may be included. If any items are missing, please contact our parts/service department at (800) 633-5096 or in Dallas (972) 869-0111/ 9am – 4pm Mon-Fri Central time. Missing or damaged hardware and/ or parts will be replaced free of charge. WE DO NOT SELL PARTS. WE DO NOT RECOMMEND MODIFYING PRODUCT(S) AND WE ARE NOT RESPONSIBLE FOR ANY DAMAGES DUE TO PRODUCT MODIFICATION(S). If this product has not been purchased from our retail affiliates (within 9 months), we are under no obligation to provide parts or replacement merchandise. Parts will not be available for items arriving fully assembled.

PARTS REPLACEMENT FORM			
STYLE NO: BE868100TX			
Customer Name	PARTS LETTER	PART DESCRIPTION	QUANTITY NEEDED
<hr/>			
Street, City, State, Zip			
<hr/>			
Phone#			
<hr/>			
		<hr/>	
		<hr/>	
		Please indicate where you purchased this item. Store/website/catalog	
		/ /	
SOUTHERN ENTERPRISES INC. P.O. Box 59996 Dallas, Texas 75229		Please indicate color/size/style number	
		/ /	