



STYLE NO: **BE6623 – WHITE**  
**BE8623 - BLACK**







**SOUTHERN ENTERPRISES INC.**

RELAX...If you can follow a few easy, step-by-step directions in order .YOU CAN ASSEMBLE THIS ITEM.

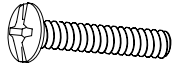
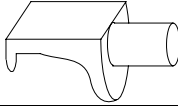
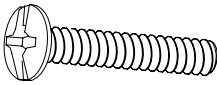
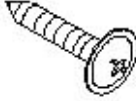
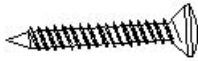
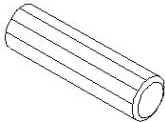
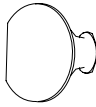
**ARCH-TOP**

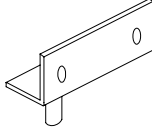
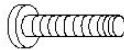
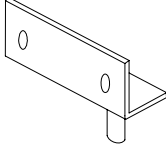
**HAMPER CABINET**

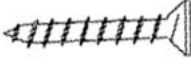
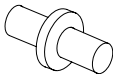

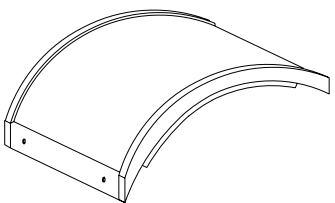
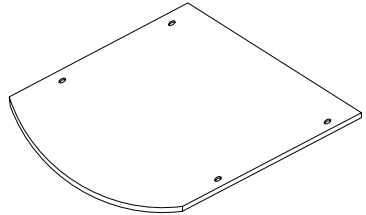
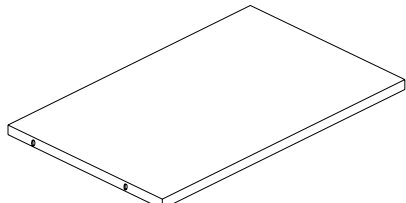
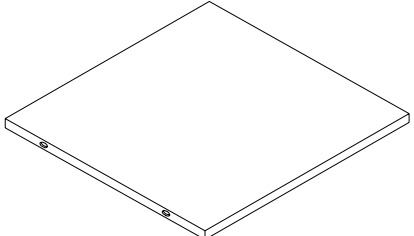
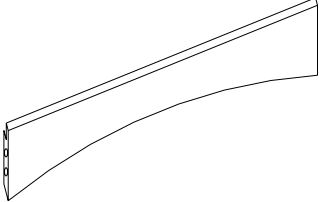
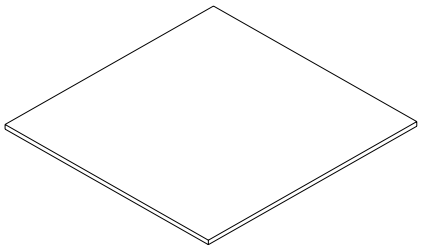
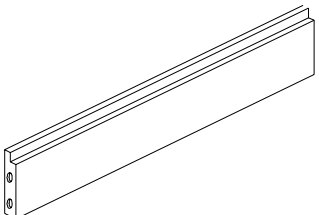
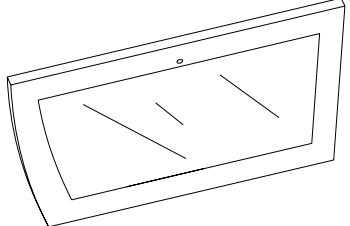
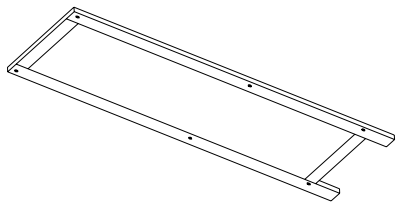
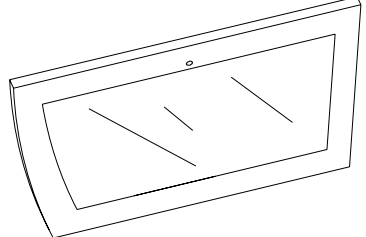
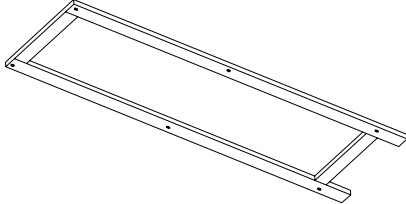
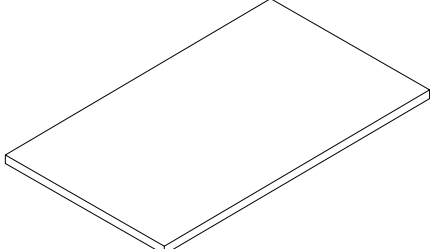

**PLEASE FIND HARDWARE IN RED POLYBAG BEFORE DISCARDING PACKING MATERIAL.**

<b>HARDWARE LIST</b>			
(1) MACHINE SCREWS (Ø1/4"X1")	4PCS	(9) SHELF SUPPORTS	4PCS
			
(2) MACHINE SCREWS (Ø1/4"X1-1/2")	8PCS	(10) PAN HEAD WOOD SCREWS(Ø2.6X10mm)	18PCS
			
(3) FLAT HEAD WOOD SCREWS(Ø3X18mm)	8PCS	(11) WOOD DOWELS	8PCS
			
(4) METAL KNOBS	3PCS	(12) PLASTIC PLUGS	12PCS
			
(5) RIGHT METAL HINGE	1PC	(13) MACHINE SCREWS (Ø5/32"X5/8")	3PCS
			
(6) LEFT METAL HINGE	1PC	(14) T-BOLTS	8PCS
			
(7) FLAT HEAD WOOD SCREWS (Ø3X10mm)	4PCS	(15) LARGE FLAT HEAD WOOD SCREW	2PCS
		 Ø4X25mm	
(8) METAL HINGES	2PCS	(16) PLASTIC ANCHORS	2PCS
			

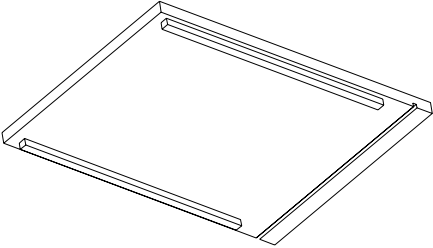
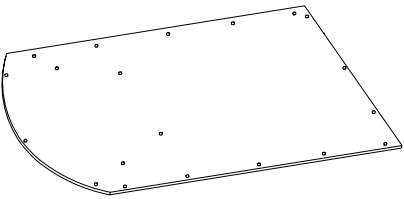
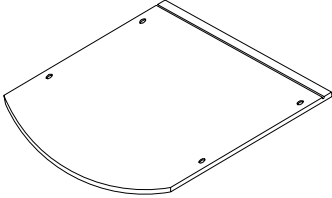
**PARTS LIST**

<p>(A) TOP PANEL</p> <p align="right">1PC</p> 	<p>(I) HAMPER LEFT SIDE PANEL</p> <p align="right">1PC</p> 
<p>(B) FIXED SHELF</p> <p align="right">1PC</p> 	<p>(J) HAMPER BACK PANEL</p> <p align="right">1PC</p> 
<p>(C) FRONT CROSS BRACE</p> <p align="right">1PC</p> 	<p>(K) HAMPER BOTTOM PANEL</p> <p align="right">1PC</p> 
<p>(D) BACK CROSS BRACE</p> <p align="right">1PC</p> 	<p>(L) RIGHT DOOR</p> <p align="right">1PC</p> 
<p>(E) LEFT SIDE PANEL</p> <p align="right">1PC</p> 	<p>(M) LEFT DOOR</p> <p align="right">1PC</p> 
<p>(F) RIGHT SIDE PANEL</p> <p align="right">1PC</p> 	<p>(N) ADJUSTABLE SHELF</p> <p align="right">1PC</p> 

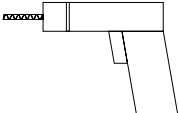
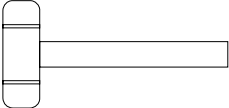
<p>(G) HAMPER FRONT PANEL 1PC</p> 	<p>(O) BACK PANEL 1PC</p> 
<p>(H) HAMPER RIGHT SIDE PANEL 1PC</p> 	

<p><b>TOOLS LIST (NOT INCLUDED)</b></p>	
<p>RULER</p> 	<p>PENCIL</p> 
<p>DRILL &amp; ¼" DRILL BIT</p> 	<p>HAMMER</p> 
<p>PHILLIP SCREWDRIVER</p> 	

**ASSEMBLY INSTRUCTION**

1. SELECT A SMOOTH, SOFT SURFACE TO PREVENT SCRATCHING FINISH.
2. YOU MAY NEED ABOVE TOOLS FOR ASSEMBLY.
3. INSERT FLAT HEAD WOOD SCREWS (Ø3X18mm) (3) THROUGH PREDRILLED HOLES ON OUTSIDE OF HAMPER LEFT SIDE PANEL (I) AND TIGHTEN INTO PREDRILLED HOLES ON ENDS OF HAMPER FRONT PANEL (G) AND HAMPER BACK PANEL (J). SLIDE HAMPER BOTTOM PANEL (K) INTO GROOVES ON HAMPER FRONT PANEL (G) AND HAMPER BACK PANEL (J) AND ALIGN WITH GROOVE ON HAMPER LEFT SIDE PANEL (I). PERFORM THE SAME WAY TO ASSEMBLE HAMPER RIGHT SIDE PANEL (H). INSERT MACHINE SCREWS (Ø5/32"X5/8") (13) THROUGH PREDRILLED HOLE ON BACK OF HAMPER FRONT PANEL (G) AND TIGHTEN INTO METAL KNOB (4). AS SHOWN IN FIGURE 1.
4. INSERT WOOD DOWELS (11) INTO PREDRILLED HOLES ON ENDS OF FIXED SHELF (B), FRONT AND BACK CROSS BRACE (C, D) AND FIT INTO CORRESPONDING HOLES ON INSIDE OF LEFT SIDE PANEL (E). INSERT T-BOLTS (14) INTO PREDRILLED HOLES ON UNDERSIDE OF FIXED SHELF (B), FRONT AND BACK CROSS BRACE (C, D). INSERT MACHINE SCREWS (Ø1/4"X1-1/2") (2) THROUGH PREDRILLED HOLES ON OUTSIDE OF LEFT SIDE PANEL (E) AND TIGHTEN INTO T-BOLTS (14). PLEASE NOTE THAT IF SCREWS DO NOT TIGHTEN, ROTATE T-BOLTS (14) SO THAT THE THREADS OF T-BOLTS (14) ARE FACING SCREWS. TIGHTEN MACHINE SCREWS (Ø1/4"X1") (1) THROUGH PREDRILLED HOLES ON OUTSIDE OF LEFT SIDE PANEL (E) INTO CORRESPONDING HOLES ON END OF TOP PANEL (A). PUSH PLASTIC PLUGS (12) INTO HOLES ON OUTSIDE OF LEFT SIDE PANEL (E) AS SHOWN IN FIGURE 2.

5. PLACE ASSEMBLED HAMPER CABINET INTO THE SPACE OF BETWEEN OF FIXED SHELF (B) AND FRONT AND BACK CROSS BRACE (C, D), FIT THE METAL TAGS OF HAMPER CABINET INTO PREDRILLED HOLES ON INSIDE OF LEFT SIDE PANEL (E). AS SHOWN IN FIGURE 2.

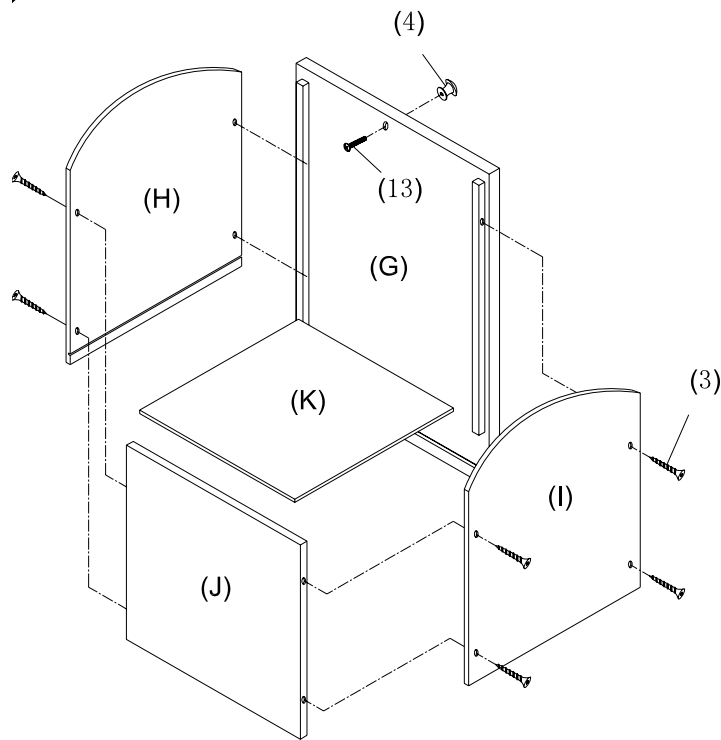

**FIGURE 1**

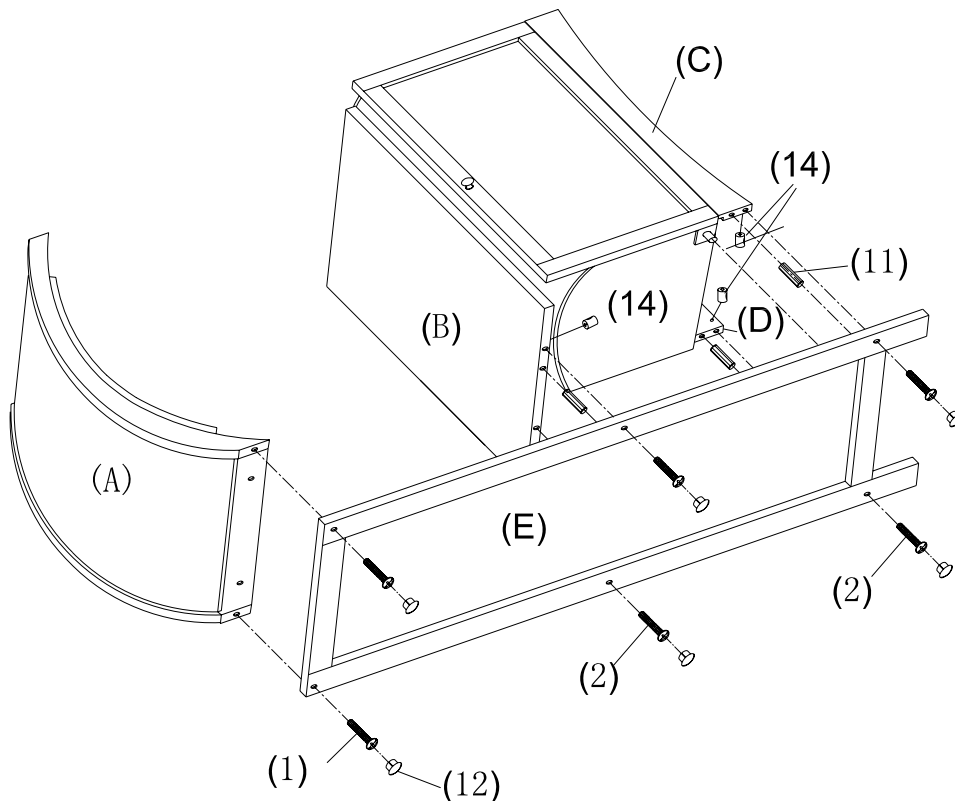

**FIGURE 2**

6. REPEAT THE STEP 4 TO ASSEMBLE RIGHT SIDE PANEL (F). AS SHOWN IN FIGURE 3.
7. INSERT METAL HINGES (8) INTO PREDRILLED HOLES ON TOP EDGES OF LEFT AND RIGHT DOORS (M, L) AND FIT INTO CORRESPONDING HOLES ON UNDERSIDE OF TOP PANEL (A). INSERT LEFT AND RIGHT METAL HINGES (5, 6) INTO PREDRILLED HOLES ON UPSIDE OF FIXED SHELF (B). INSERT FLAT HEAD WOOD SCREWS ( $\varnothing 3 \times 10 \text{mm}$ ) (7) THROUGH LEFT AND RIGHT METAL HINGES (6,

- 5) AND TIGHTEN INTO PREDRILLED HOLES ON LEFT AND RIGHT DOORS (M, L). INSERT MACHINE SCREWS ( $\text{Ø}5/32'' \times 5/8''$ ) (13) THROUGH PREDRILLED HOLES ON LEFT AND RIGHT DOORS (M, L) AND TIGHTEN INTO METAL KNOBS (4). AS SHOWN IN FIGURE 4.
8. FIT SHELF SUPPORTS (9) INTO PREDRILLED HOLES ON LEFT AND RIGHT SIDE PANELS (E, F). PUT ADJUSTABLE SHELF (N) ON EACH SHELF SUPPORTS (9). AS SHOWN IN FIGURE 4.

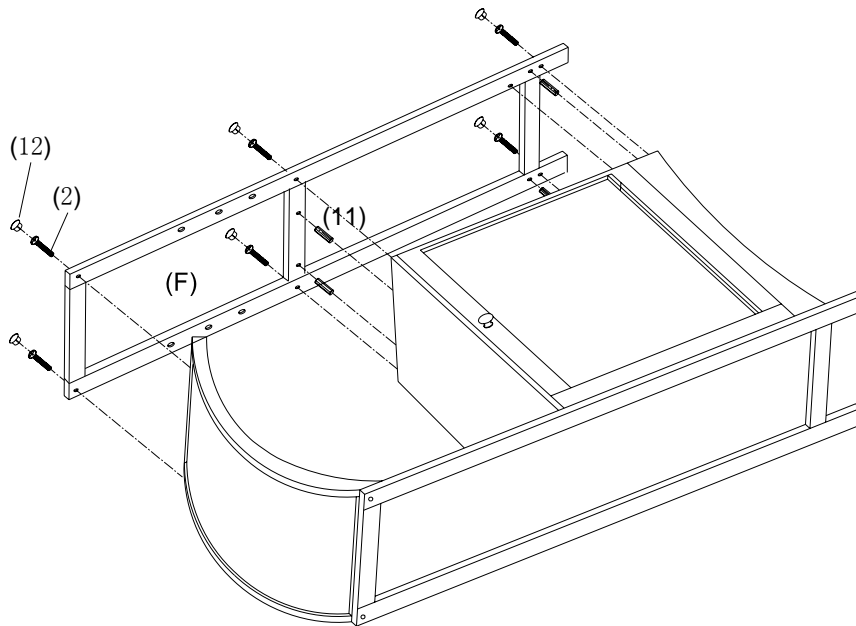

**FIGURE 3**

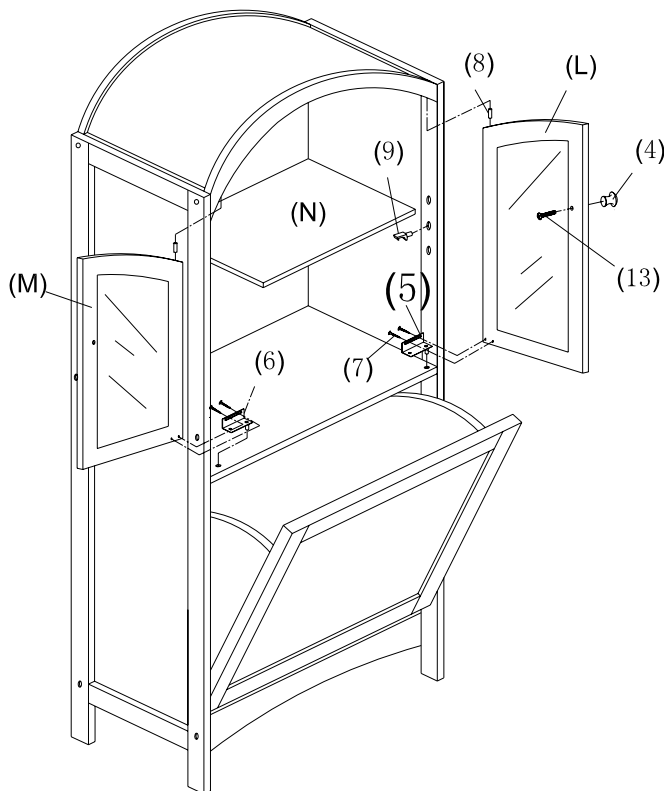

**FIGURE 4**

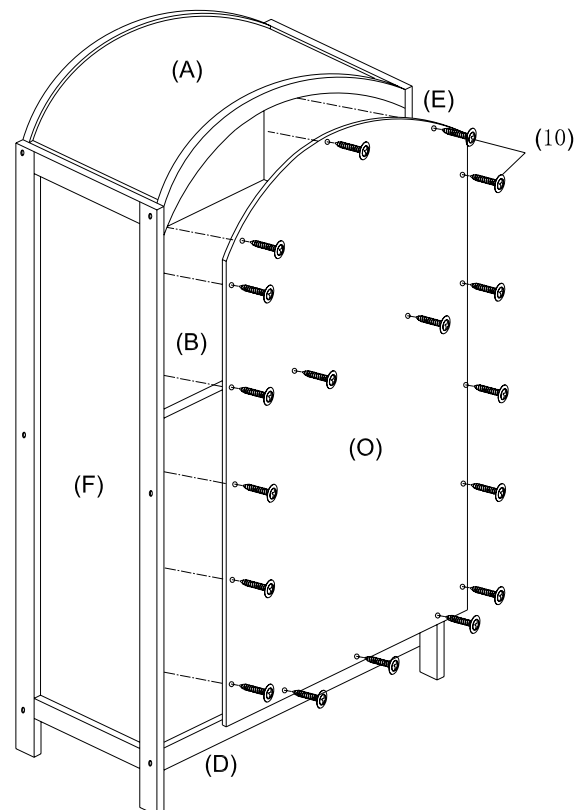

**FIGURE 5**

9. ATTACH BACK PANEL (O) INTO SLOTS ON PARTS (A, E, F, D). INSERT PAN HEAD WOOD SCREWS ( $\text{Ø}2.6 \times 10\text{mm}$ ) (10) THROUGH PREDRILLED HOLES ON BACK PANEL (O) AND TIGHTEN INTO CORRESPONDING HOLES ON REAR EDGES OF PARTS (A, B, E, F, D). AS SHOWN IN FIGURE 5.

10. FOR SAFETY SAKE, SUGGEST TO PLACE THE UNIT AGAINST WALL, YOU SHOULD DRILL TWO 1/4" DIAMETER HOLES ON WALL, THE DISTANCE BETWEEN TWO HOLES TO BE 11" AND SHOULD MATCH THE PREDRILLED HOLES ON BACK PANEL (O). FIT PLASTIC ANCHORS (16) INTO THE HOLES ON WALL. USE SCREWDRIVER TO SCREW LARGE FLAT HEAD WOOD SCREWS (Ø4X25mm) (15) THROUGH PREDRILLED HOLES ON BACK PANEL (O) INTO PLASTIC ANCHORS (16). AS SHOWN IN FIGURE 6.

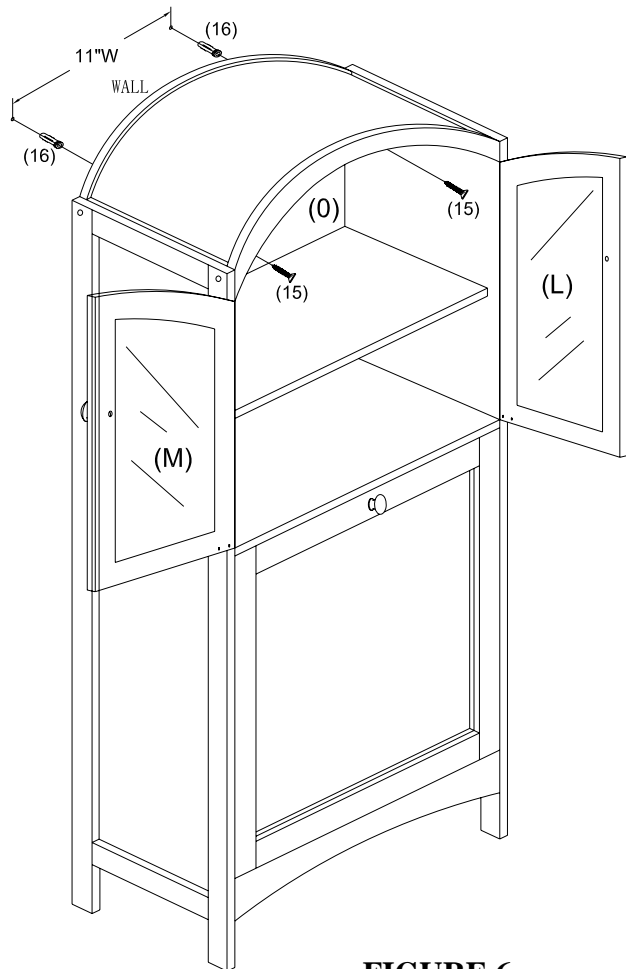

**FIGURE 6**

**YOUR NEW ARCH-TOP HAMPER CABINET IS FINISHED AND READY TO USE.**

Please count, identify and compare parts and hardware list to be sure all parts are present. It may help to divide parts and label them to correspond with part list. Extra hardware may be included. If any items are missing, please contact our parts/service department at (800) 633-5096 or in Dallas (972) 869-0111/ 9am – 4pm Mon-Fri Central time. Missing or damaged hardware and/ or parts will be replaced free of charge. WE DO NOT SELL PARTS. WE DO NOT RECOMMEND MODIFYING PRODUCT(S) AND WE ARE NOT RESPONSIBLE FOR ANY DAMAGES DUE TO PRODUCT MODIFICATION(S). If this product has not been purchased from our retail affiliates (within 9 months), we are under no obligation to provide parts or replacement merchandise. Parts will not be available for items arriving fully assembled.

**"We will ship parts if available" "This is not a warranty"**

**PARTS REPLACEMENT FORM**

STYLE NO: **BE6623/BE8623**

Customer Name

PARTS  
LETTER

PART  
DESCRIPTION

QUANTITY  
NEEDED

Street, City, State, Zip

Phone#



SOUTHERN ENTERPRISES INC.  
P.O. Box 59996 Dallas, Texas 75229

\_\_\_\_\_  
Please indicate where you purchased this item.

Store/website/catalog

/ /

\_\_\_\_\_  
Please indicate color/size/style number

/ /