













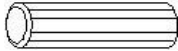

WHITE STYLE NO: **BE7181**
NATURAL STYLE NO: **BE7581**

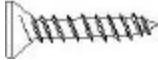

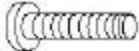

SOUTHERN ENTERPRISES INC.



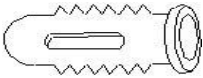















RELAX...If you can follow a few easy, step-by-step directions in order .YOU CAN ASSEMBLE THIS ITEM.

NASSAU SPACESAVER

PLEASE FIND HARDWARE IN RED POLYBAG BEFORE DISCARDING PACKING MATERIAL.

HARDWARE LIST			
(1) WOOD DOWELS	40PCS	(8) SHELF SUPPORTS	8PCS
			
(2) METAL KNOBS	4PCS	(9) T-BOLTS	12PCS
			
(3) LONG FLAT HEAD WOOD SCREWS	6PCS	(10) LOCK WASHERS	12PCS
			
(4) SHORT FLAT HEAD WOOD SCREWS	8PCS	(11) LONG MACHINE SCREWS	12PCS
			
(5) LONG PAN HEAD WOOD SCREWS	16PCS	(12) PLASTIC COVERS	8PCS
			
(6) SHORT PAN HEAD WOOD SCREWS	20PCS	(13) SHORT MACHINE SCREWS	4PCS
			
(7) MAGNET	1PC	(14) PLASTIC ANCHORS	2PCS
			

PARTS LIST			
(A) LEFT UPPER SIDE PANEL	1PCS	(L) BACK PANEL	1PC
			
(B) RIGHT UPPER SIDE PANEL	1PCS	(M) LEFT SIDE DOOR	1PC
			

(C) LEFT LOWER SIDE PANEL 	1PC	(N) RIGHT SIDE DOOR 	1PC
(D) RIGHT LOWER SIDE PANEL 	1PC	(O) LOWER BACK CROSS BRACE 	1PC
(E) TOP PANEL 	1PC	(P) DIVIDER 	1PC
(F) BOTTOM PANEL 	1PC	(Q) LEFT DRAWER FRONT PANEL 	1PC
(G) UPPER BACK CROSS BRACE 	1PC	(R) DRAWER BACK PANELS 	2PCS
(H) FRONT CROSS BRACE 	1PC	(S) DRAWER BOTTOM PANELS 	2PCS
(I) MIDDLE BACK CROSS BRACE 	1PC	(T) DRAWER LEFT SIDE PANELS 	2PCS
(J) FIXED SHELF 	1PC	(U) DRAWER RIGHT SIDE PANELS 	2PCS
(K) ADJUSTABLE SHELVES 	2PCS	(V) RIGHT DRAWER FRONT PANEL 	1PC

ASSEMBLY INSTRUCTION

1. SELECT A SMOOTH, SOFT SURFACE TO PREVENT SCRATCHING FINISH.
2. YOU MAY NEED A PHILIP SCREWDRIVER.

3. INSERT WOOD DOWELS (1) INTO ENDS OF UPPER BACK CROSS BRACE (G), FIXED SHELF (J) AND FIT INTO THE CORRESPONDING HOLES ON INSIDE OF THE LEFT AND RIGHT UPPER SIDE PANELS (A, B). AS FIGURE 1 AND INSET SHOWN.

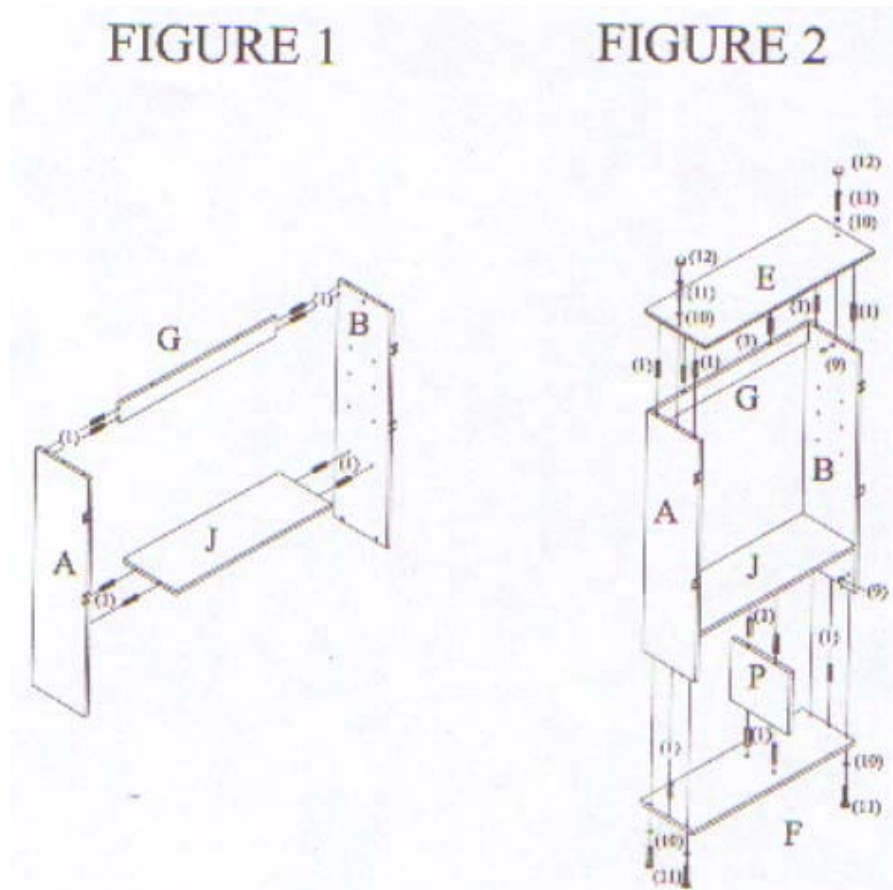

4. INSERT WOOD DOWELS (1) INTO EDGES OF UPPER BACK CROSS BRACE (G), LEFT UPPER SIDE PANEL (A), RIGHT UPPER SIDE PANELS (B) AND FIT INTO CORRESPONDING HOLES ON TOP PANEL (E). INSERT T-BOLTS (9) INTO THE HOLES NEAR TOP EDGES OF LEFT AND RIGHT UPPER SIDE PANELS (A, B) WITH SLOT FOR SCREWDRIVER FACING OUTWARD. INSERT LONG MACHINE SCREWS (11) THROUGH LOCK WASHERS (10), PREDRILLED HOLES ON TOP PANEL (E) AND TIGHTEN INTO T-BOLTS (9). INSERT WOOD DOWELS (1) INTO TOP EDGE OF DIVIDER (P) AND FIT INTO CORRESPONDING HOLES ON UNDERSIDE OF FIXED SHELF (J). INSERT WOOD DOWELS (1) INTO PREDRILLED HOLES ON BOTTOM EDGES OF DIVIDER (P), LEFT AND RIGHT UPPER SIDE PANELS (A, B) AND FIT INTO CORRESPONDING HOLES ON BOTTOM PANEL (F). INSERT T-BOLTS (9) INTO THE HOLES NEAR BOTTOM EDGES OF LEFT AND RIGHT UPPER SIDE PANELS (A, B). INSERT LONG MACHINE SCREWS (11) THROUGH LOCK WASHERS (10), PREDRILLED HOLES ON BOTTOM PANEL (F) AND TIGHTEN INTO T-BOLTS (9). PLEASE NOTE THAT IF SCREWS DO NOT TIGHTEN, ROTATE T-BOLTS (9) SO THAT THREADS OF T-BOLTS (9) FACING LONG MACHINE SCREWS (11). PUSH PLASTIC COVERS 12) INTO HOLES ON TOP PANEL (E) ONLY. AS FIGURE 2 SHOWN.

- ATTACH BACK PANEL (L) INTO SLOT OF PARTS (A, B, F, G). TIGHTEN SHORT PAN HEAD WOOD SCREWS (6) THROUGH PREDRILLED HOLES ON BACK PANEL (L) INTO REAR EDGES OF PARTS (A, B, F, G). AS FIGURE 3 SHOWN.

FIGURE 3

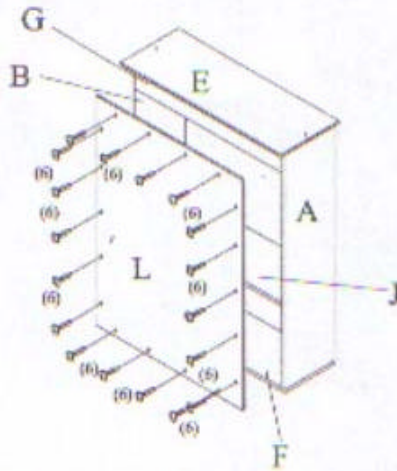
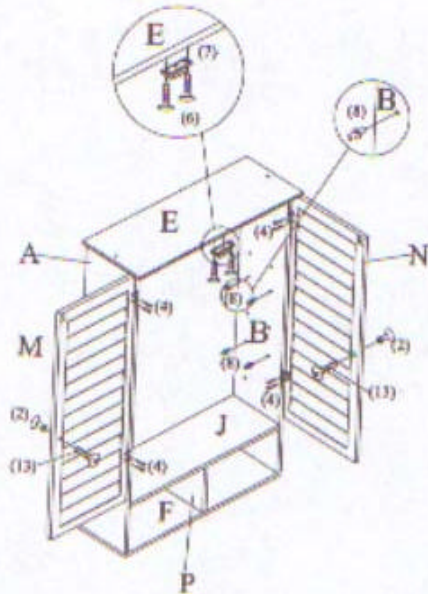

FIGURE 4



- INSERT SHORT PAN HEAD WOOD SCREWS (6) THROUGH ENDS OF MAGNET (7) AND TIGHTEN INTO PREDRILLED HOLES ON UNDERSIDE OF TOP PANEL (E). INSERT SHORT FLAT HEAD WOOD SCREWS (4) THROUGH HINGES ON LEFT AND RIGHT UPPER SIDE PANELS (A, B) AND TIGHTEN INTO PREDRILLED HOLES ON BACK OF LEFT AND RIGHT SIDE DOORS (M, N). INSERT SHORT MACHINE SCREWS (13) THROUGH BACK OF LEFT AND RIGHT SIDE DOORS (M, N) AND TIGHTEN INTO METAL KNOBS (2). AS FIGURE 4 AND INSET SHOWN.
- FIT SHELF SUPPORTS (8) INTO PREDRILLED HOLES ON INSIDE OF LEFT AND RIGHT UPPER SIDE PANELS (A, B). PUT ADJUSTABLE SHELVES (K) ON EACH SHELF SUPPORT (8) MATCHING THE POSITION OF GROOVES ON ADJUSTABLE SHELVES (K). AS FIGURE 5 AND INSET SHOWN.

FIGURE 5

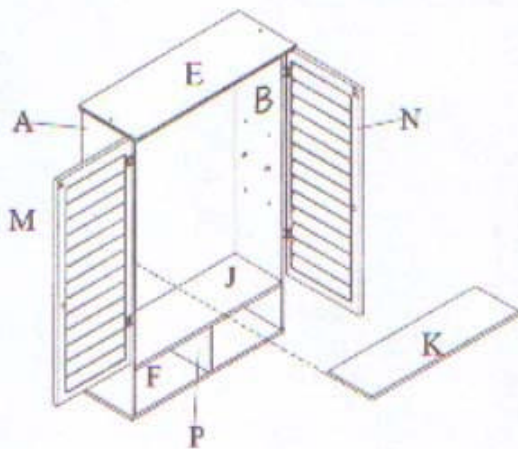
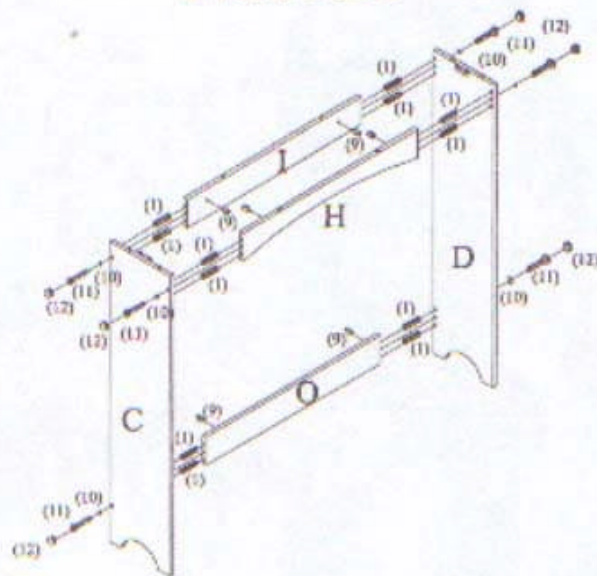

FIGURE 6



8. INSERT WOOD DOWELS (1) INTO EDGES OF FRONT CROSS BRACE (H), MIDDLE BACK CROSS BRACE (I), LOWER BACK CROSS BRACE (O) AND FIT INTO CORRESPONDING HOLES ON INSIDE OF LEFT AND RIGHT LOWER SIDE PANELS (C, D). INSERT T-BOLTS (9) INTO THE HOLES ON ALL CROSS BRACES (H, I, O) WITH SLOT FOR SCREWDRIVER FACING OUTWARD. INSERT LONG MACHINE SCREWS (11) THROUGH LOCK WASHERS (10), PREDRILLED HOLES ON OUTSIDE OF LEFT AND RIGHT LOWER SIDE PANELS (C, D) AND TIGHTEN INTO T-BOLTS (9). PLEASE NOTE THAT IF SCREWS DO NOT TIGHTEN, ROTATE T-BOLTS (9) SO THAT THREADS OF T-BOLTS (9) FACING LONG MACHINE SCREWS (11). PUSH PLASTIC COVERS (12) INTO HOLES ON OUTSIDE OF LEFT AND RIGHT LOWER SIDE PANELS (C, D). AS FIGURE 6 AND INSET SHOWN.
9. INSERT WOOD DOWELS (1) INTO TOP OF FRONT CROSS BRACE (H), MIDDLE BACK CROSS BRACE (I), LEFT AND RIGHT LOWER SIDE PANELS (C, D). WITH AN ASSISTANT, LIFT ASSEMBLED UNIT ABOVE THE BASE AND INSERT WOOD DOWELS (1) EXTENDING FROM THE BASE INTO THE CORRESPONDING HOLES ON UNDERSIDE OF BOTTOM PANEL (F). INSERT LONG FLAT HEAD WOOD SCREWS (3) THROUGH PREDRILLED HOLES ON WOOD BAR ON LEFT AND RIGHT LOWER SIDE PANELS (C, D) AND TIGHTEN INTO PREDRILLED HOLES ON UNDERSIDE OF BOTTOM PANEL (F). AS FIGURE 7 AND INSET SHOWN.

FIGURE 7

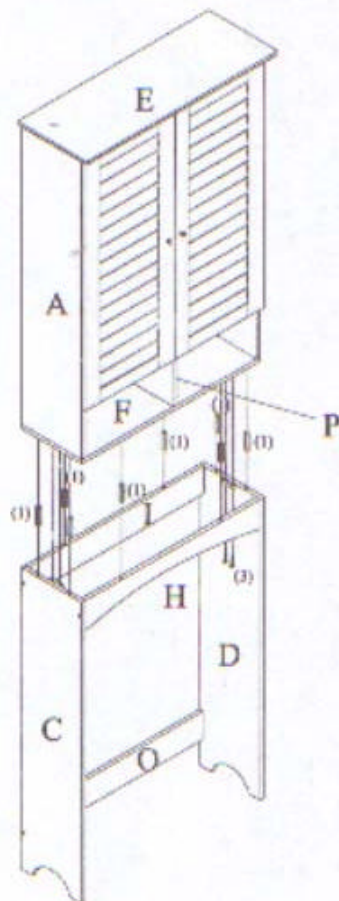
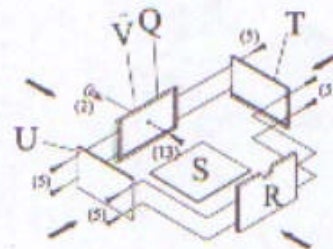
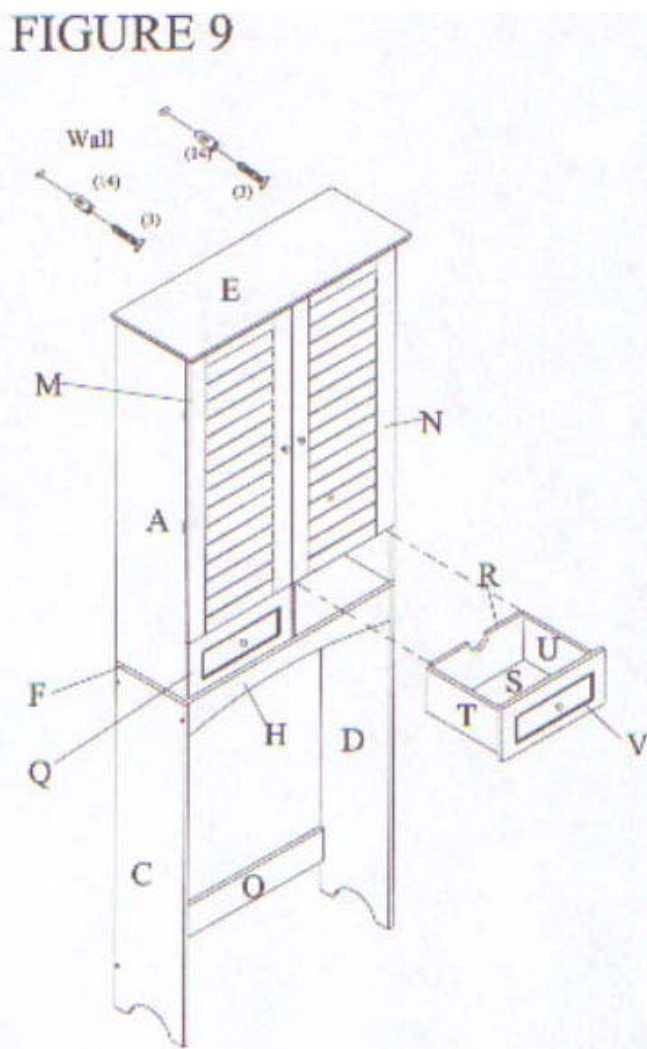

FIGURE 8



10. INSERT SHORT MACHINE SCREW (13) THROUGH BACK OF LEFT AND RIGHT DRAWER FRONT PANELS (Q, V) AND TIGHTEN INTO METAL KNOBS (2). INSERT LONG PAN HEAD WOOD SCREWS (5) THROUGH PREDRILLED HOLES ON OUTSIDE OF DRAWER RIGHT SIDE PANEL (U) AND TIGHTEN INTO PREDRILLED HOLES ON ENDS OF LEFT DRAWER FRONT PANEL (Q) AND DRAWER BACK PANEL (R). SLIDE DRAWER BOTTOM PANEL (S) INTO GROOVES ON LEFT DRAWER FRONT PANEL (Q) AND DRAWER BACK PANEL (R) AND ALIGN WITH GROOVE ON DRAWER RIGHT SIDE PANEL (U). INSERT LONG PAN HEAD WOOD SCREWS (5) THROUGH PREDRILLED HOLES ON OUTSIDE OF DRAWER LEFT SIDE PANEL (T) AND TIGHTEN INTO PREDRILLED HOLES ON ENDS OF LEFT DRAWER FRONT PANEL (Q) AND DRAWER BACK PANEL (R). PERFORM THE SAME WAY TO ASSEMBLE RIGHT DRAWER FRONT PANEL (V), DRAWER BACK PANEL (R), DRAWER BOTTOM PANEL (S), DRAWER LEFT AND RIGHT PANELS (T, U). AS FIGURE 8 SHOWN.
11. PLACE THE ASSEMBLED DRAWERS INTO THE SPACE OF THE UNIT. AS FIGURE 9 SHOWN.
12. IN ORDER TO STAND STURDILY. DRILL TWO 1/4" DIAMETER HOLES ON WALL, THE DISTANCE BETWEEN TWO HOLES SHOULD MATCH TO THE HANGING HOLES ON BACK OF UPPER BACK CROSS BRACE (G). FIT PLASTIC ANCHORS (14) INTO THE HOLES ON WALL. USE SCREWDRIVER TO FIT LONG FLAT HEAD WOOD SCREWS (3) INTO PLASTIC ANCHORS (14). THEN FIT HANGING HOLES ON UPPER BACK CROSS BRACE (G) TO THE LONG FLAT HEAD WOOD SCREWS (3). AS FIGURE 9 SHOWN.

YOUR NEW NASSAU SPACESAVER IS FINISHED AND READY TO USE.



Please count, identify and compare parts and hardware list to be sure all parts are present. Extra hardware may be included. If any items are missing, please contact our parts/ service department at (800) 633-5096 or in Dallas (972) 869-0111/ 9am-4pm Mon-Fri central time. Missing or damaged hardware and/ or parts will be replaced free of charge. WE DO NOT SELL PARTS.

WE DO NOT RECOMMEND MODIFYING PRODUCT(S) AND WE ARE NOT RESPONSIBLE FOR ANY DAMAGES DUE TO PRODUCT MODIFICATION(S).

PARTS REPLACEMENT FORM

WHITE STYLE NO: **BE7181**

NATURAL STYLE NO: **BE7581**

Customer Name

PARTS
LETTER

PART
DESCRIPTION

QUANTITY
NEEDED

Street, City, State, Zip

Phone#



SOUTHERN ENTERPRISES INC.
P.O. Box 59996 Dallas, Texas 75229

Please indicate where you purchased this item.
Store/website/catalog

/ /

Please indicate color/size/style number

/ /