







JCPLOT# 794- 5006
 STYLE NO. BE6842

SOUTHERN ENTERPRISES INC.

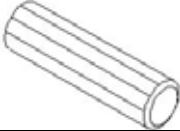
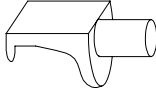
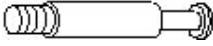
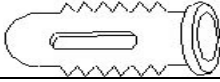

**WHITE MARIETTA
 WALL CABINET**

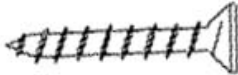
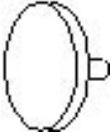
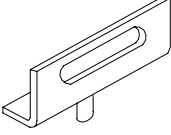
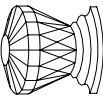
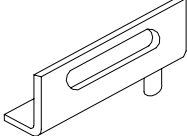
RELAX...If you can follow a few easy, step-by-step directions
 in order .YOU CAN ASSEMBLE THIS ITEM.

PLEASE FIND HARDWARE IN RED POLYBAG BEFORE DISCARDING PACKING MATERIAL.

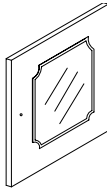
HARDWARE LIST			
(1) WOOD DOWELS	5PCS	(7) SHELF SUPPORTS	4PCS
			
(2) CAM-BOLTS	8PCS	(8) PLASTIC ANCHORS	2PCS
			
(3) CAM-LOCKS	8PCS	(9) FLAT HEAD WOOD SCREWS (Ø4X38mm)	2PCS
			
(4) COVERS	8PCS	(10) UPPER HINGE	1PC
			
(5) KNOB	1PC	(11) LOWER HINGE	1PC
			
(6) MACHINE SCREWS (Ø5/32"X3/4")	1PC	(12) FLAT HEAD WOOD SCREWS(Ø3X10mm)	4PCS
			

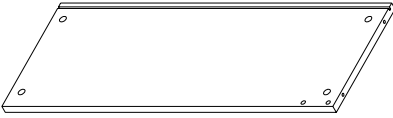
PARTS LIST			
(A) LEFT SIDE PANEL	1PC	(E) DOOR	1PC
			

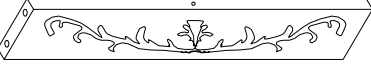
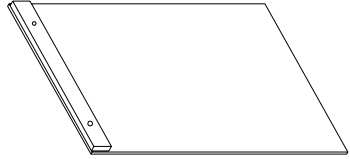
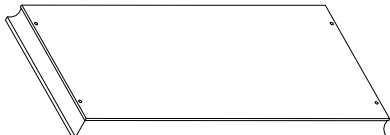
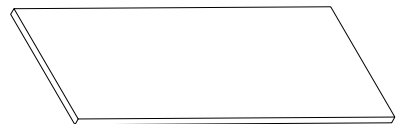
<p>(B) RIGHT SIDE PANEL 1PC</p> 	<p>(F) TOP PANEL 1PC</p> 
<p>(C) CROSS BRACE 1PC</p> 	<p>(G) BACK PANEL 1PC</p> 
<p>(D) BOTTOM PANEL 1PC</p> 	<p>(H) ADJUSTABLE SHELF 1PC</p> 

ASSEMBLY INSTRUCTION

1. SELECT A SMOOTH, SOFT SURFACE TO PREVENT SCRATCHING FINISH.
2. YOU MAY NEED A PHILLIP SCREWDRIVER.
3. INSERT WOOD DOWELS (1) INTO PREDRILLED HOLES ON ENDS OF CROSS BRACE (C) AND FIT INTO CORRESPONDING HOLES ON INSIDE OF LEFT AND RIGHT SIDE PANELS (A, B). AS FIGURE 1 SHOWN.

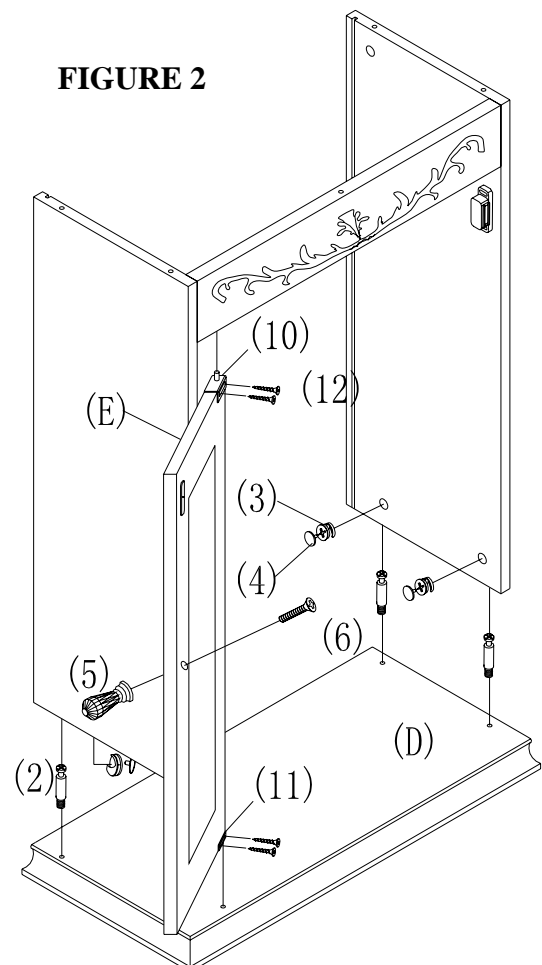
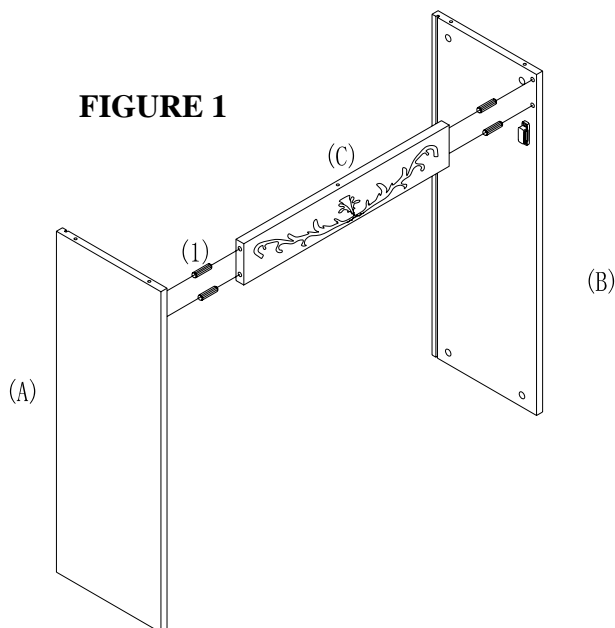

4. INSERT MACHINE SCREWS ($\text{Ø}5/32''\times 3/4''$) (6) THROUGH PREDRILLED HOLES ON BACK OF DOOR PANEL (E) AND TIGHTEN INTO KNOB (5). INSERT FLAT HEAD WOOD SCREWS ($\text{Ø}3\times 10\text{mm}$) (12) THROUGH UPPER AND LOWER HINGES (10, 11) AND TIGHTEN INTO PREDRILLED HOLES ON BACK OF DOOR PANEL (E). INSERT CAM-BOLTS (2) INTO PREDRILLED HOLES ON BOTTOM PANEL (D). INSERT UPPER AND LOWER HINGES (10, 11), CAM-BOLTS (2) INTO CORRESPONDING HOLES BOTTOM PANEL (D), CROSS BRACE (C), BOTTOM EDGES OF LEFT AND RIGHT SIDE PANELS (A, B). INSERT CAM-LOCKS (3) INTO BIG HOLES ON INSIDE OF LEFT AND RIGHT SIDE PANELS (A, B) WITH SLOT FOR SCREWDRIVER FACING OUTWARD. ROTATE CAM-LOCKS (3) CLOCKWISE TO SECURE CAM-BOLTS (2). PUSH COVERS (4) INTO CAM-LOCKS (3). AS FIGURE 2 SHOWN.
5. GENTLY SLIDE BACK PANEL (G) INTO GROOVES ON LEFT AND RIGHT SIDE PANELS (A, B) AND ALIGN TO GROOVE ON BOTTOM PANEL (D). **PLEASE NOTE THE WOOD STRIP ON BACK PANEL (G) SHOULD BE FACING OUTSIDE AND UPWARD.** INSERT WOOD DOWELS (1), CAM-BOLTS (2) INTO PREDRILLED HOLES ON TOP PANEL (F) AND FIT INTO CORRESPONDING HOLES ON TOP EDGES OF CROSS BRACE (C), LEFT AND RIGHT SIDE PANELS (A, B). INSERT CAM-LOCKS (3) INTO BIG HOLES ON INSIDE OF LEFT AND RIGHT SIDE PANELS (A, B) WITH SLOT FOR SCREWDRIVER FACING OUTWARD. ROTATE CAM-LOCKS (3) CLOCKWISE TO SECURE CAM-BOLTS (2). PUSH COVERS (4) INTO CAM-LOCKS (3). FIT SHELF SUPPORTS (7) INTO PREDRILLED HOLES ON INSIDE OF LEFT AND RIGHT SIDE PANELS (A, B). PUT ADJUSTABLE SHELF (H) ON SHELF SUPPORTS (7). AS FIGURE 3 SHOWN.
6. DRILL TWO $1/4''$ DIAMETER HOLES ON WALL, THE DISTANCE BETWEEN TWO HOLES SHOULD MATCH TO THE PREDRILLED HOLES ON BACK PANEL (G). FIT PLASTIC ANCHORS (8) INTO THE HOLES ON WALL. USE SCREWDRIVER TO TIGHTEN FLAT HEAD WOOD SCREWS ($\text{Ø}4\times 38\text{mm}$) (9) THROUGH PREDRILLED HOLES ON BACK PANEL (G) INTO PLASTIC ANCHORS (8). AS FIGURE 4 SHOWN.

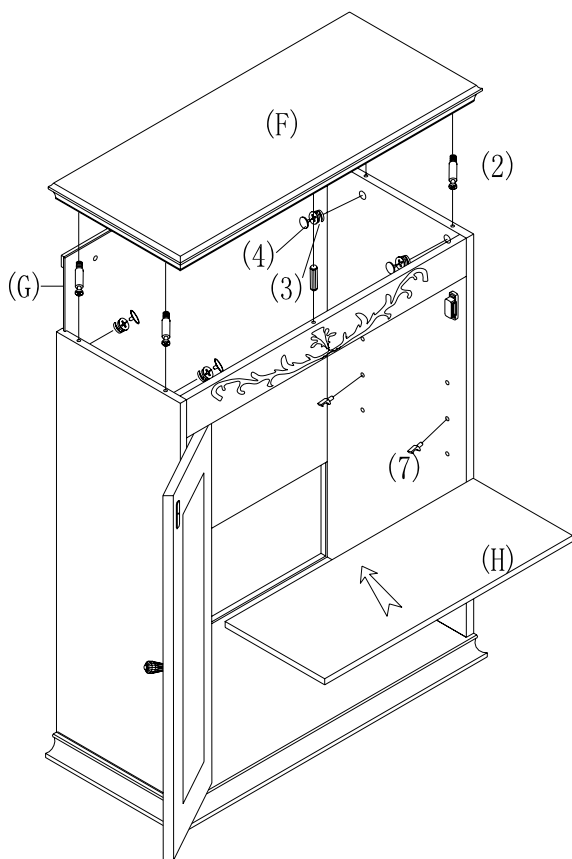
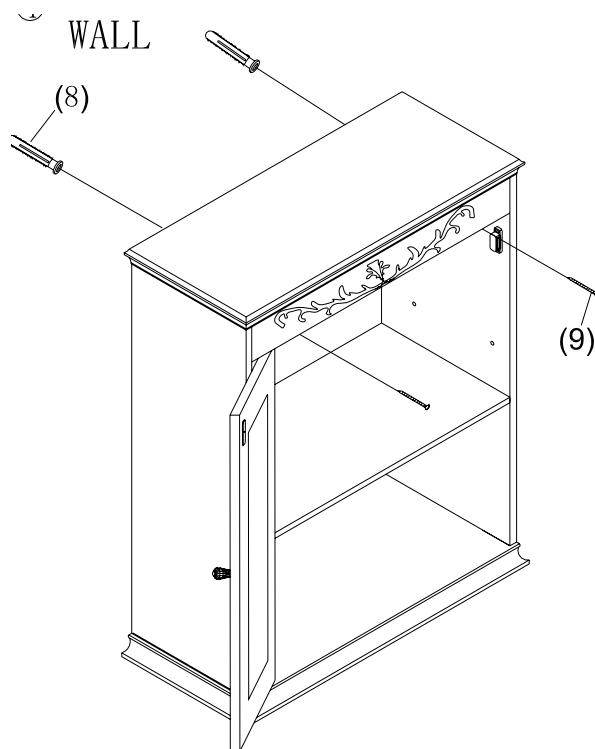
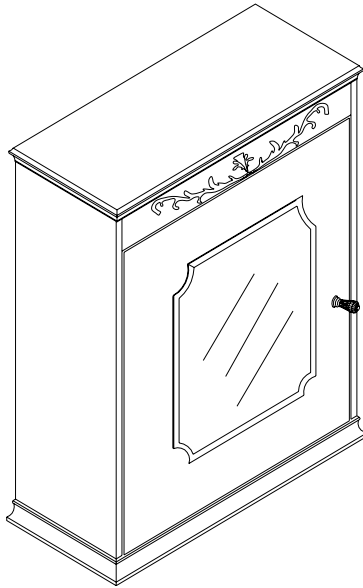

FIGURE 3



FIGURE

READY



YOUR NEW WHITE MARIETTA WALL CABINET IS FINISHED AND READY TO USE.

Please count, identify and compare parts and hardware list to be sure all parts are present. It may help to divide parts and label them to correspond with part list. Extra hardware may be included. If any items are missing, please contact our parts/service department at (800) 633-5096 or in Dallas (972) 869-0111/ 9am – 4pm Mon-Fri Central time. Missing or damaged hardware and/ or parts will be replaced free of charge. WE DO NOT SELL PARTS. WE DO NOT RECOMMEND MODIFYING PRODUCT(S) AND WE ARE NOT RESPONSIBLE FOR ANY DAMAGES DUE TO PRODUCT MODIFICATION(S). If this product has not been purchased from our retail affiliates (within 9 months), we are under no obligation to provide parts or replacement merchandise. Parts will not be available for items arrived fully assembled.

PARTS REPLACEMENT FORM

JCP LOT# **794-5006**
STYLE NO: **BE6842**

Customer Name _____

PARTS
LETTER

PART
DESCRIPTION

QUANTITY
NEEDED

Street, City, State, Zip _____

Phone# _____



Please indicate where you purchased this item.
Store/website/catalog

Please indicate color/size/style number

SOUTHERN ENTERPRISES INC.
P.O. Box 59996 Dallas, Texas 75229

NOTE: PLEASE DO NOT OVERTIGHTEN CAM LOCKS.