













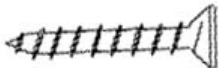

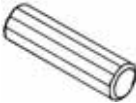
JCP LOT# 794-5006  
 STYLE NO: BE6841

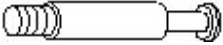
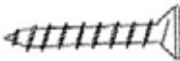
**SOUTHERN ENTERPRISES INC.**

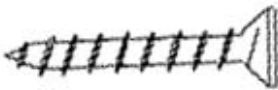
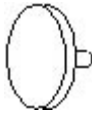
RELAX...If you can follow a few easy, step-by-step directions in order .YOU CAN ASSEMBLE THIS ITEM.

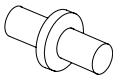
**WHITE MARIETTA  
 SPACESAVER**

**PLEASE FIND HARDWARE IN RED POLYBAG BEFORE DISCARDING PACKING MATERIAL.**

<b>HARDWARE LIST</b>			
(1) MEDIUM FLAT HEAD WOOD SCREWS (Ø4X25mm) 	12PCS	(8) KNOBS 	4PCS
(2) WOOD DOWELS 	10PCS	(9) PAN HEAD WOOD SCREWS (Ø2.6X10mm) 	19PCS
(3) CAM-BOLTS 	8PCS	(10) SMALL FLAT HEAD WOOD SCREWS (Ø3X18mm) 	8PCS
(4) CAM-LOCKS 	8PCS	(11) LARGE FLAT HEAD WOOD SCREWS (Ø4X38mm) 	2PCS
(5) COVERS 	8PCS	(12) PLASTIC ANCHORS 	2PCS
(6) METAL HINGES 	4PCS	(13) PLASTIC PLUGS 	8PCS
(7) MACHINE SCREWS (Ø5/32"X3/4") 	4PCS	(14) METAL DRAWER STOPPER 	1PC

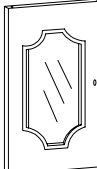
<b>PARTS LIST</b>			
(A) LEFT LOWER SIDE PANEL 	1PC	(J) LEFT DOOR 	1PC

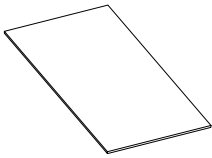
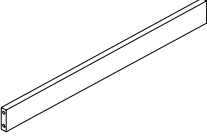
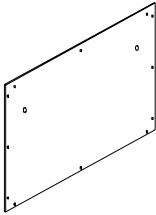
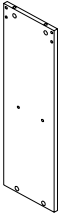
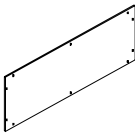
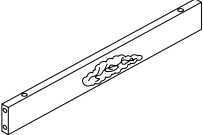
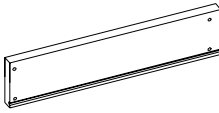
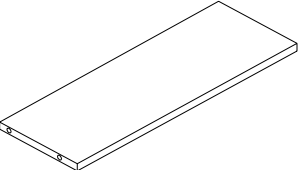
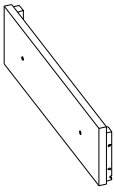
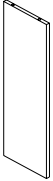
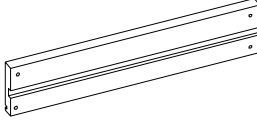
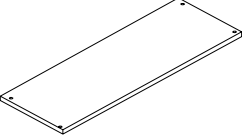
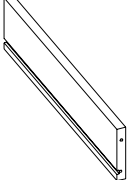
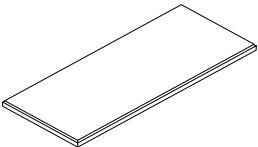
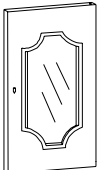
<p>(B) RIGHT LOWER SIDE PANEL 1PC</p> 	<p>(K) DRAWER BOTTOM PANEL 1PC</p> 
<p>(C) UPPER BACK CROSS BRACE 1PC</p> 	<p>(L) UPPER BACK PANEL 1PC</p> 
<p>(D) RIGHT UPPER SIDE PANEL 1PC</p> 	<p>(M) LOWER BACK PANEL 1PC</p> 
<p>(E) FRONT CROSS BRACE 1PC</p> 	<p>(N) DRAWER LEFT PANEL 1PC</p> 
<p>(F) FIXED SHELF 1PC</p> 	<p>(O) DRAWER FRONT PANEL 1PC</p> 
<p>(G) LEFT UPPER SIDE PANEL 1PC</p> 	<p>(P) DRAWER RIGHT PANEL 1PC</p> 
<p>(H) BOTTOM PANEL 1PC</p> 	<p>(Q) DRAWER BACK PANEL 1PC</p> 
<p>(I) TOP PANEL 1PC</p> 	<p>(R) RIGHT DOOR 1PC</p> 

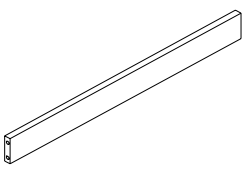
(S) LOWER BACK CROSS BRACE	IPC	
		

### ASSEMBLY INSTRUCTION

1. SELECT A SMOOTH, SOFT SURFACE TO PREVENT SCRATCHING FINISH.
2. YOU MAY NEED A PHILIP SCREWDRIVER.
3. INSERT MEDIUM FLAT HEAD WOOD SCREWS (Ø4X25mm) (1) THROUGH PREDRILLED HOLES ON OUTSIDE OF LEFT AND RIGHT LOWER SIDE PANELS (A, B) AND TIGHTEN INTO CORRESPONDING HOLES ON ENDS OF UPPER AND LOWER BACK CROSS BRACE (C, S). PUSH PLASTIC PLUGS (13) INTO THE BIG HOLES ON OUTSIDE OF LEFT AND RIGHT LOWER SIDE PANELS (A, B). (AS SHOWN IN FIGURE 1 )
4. INSERT MEDIUM FLAT HEAD WOOD SCREWS (Ø4X25mm) (1) THROUGH PREDRILLED HOLES ON BOTTOM PANEL (H) AND TIGHTEN INTO CORRESPONDING HOLES ON TOP EDGES OF LEFT AND RIGHT LOWER SIDE PANELS (A, B). (AS SHOWN IN FIGURE 2 )
5. INSERT WOOD DOWELS (2) INTO PREDRILLED HOLES ON ENDS OF FRONT CROSS BRACE AND FIXED SHELF (E, F) AND FIT INTO CORRESPONDING HOLES ON INSIDES OF LEFT AND RIGHT UPPER SIDE PANELS (G, D). (AS SHOWN IN FIGURE 3 )

**FIGURE 1**

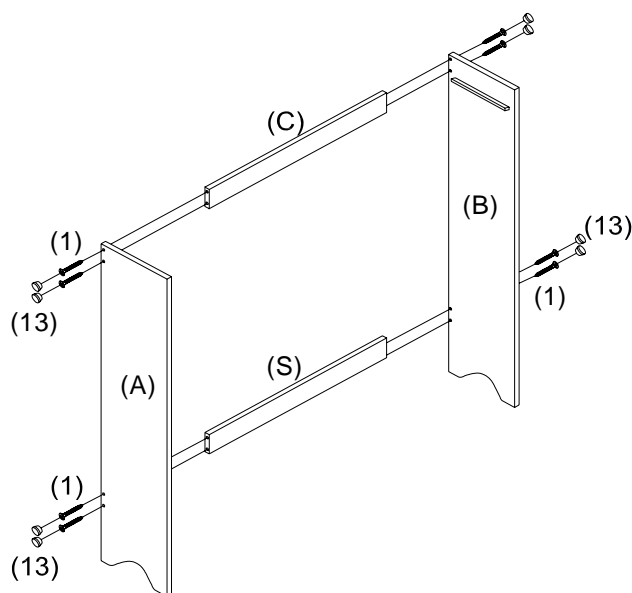

**FIGURE 2**

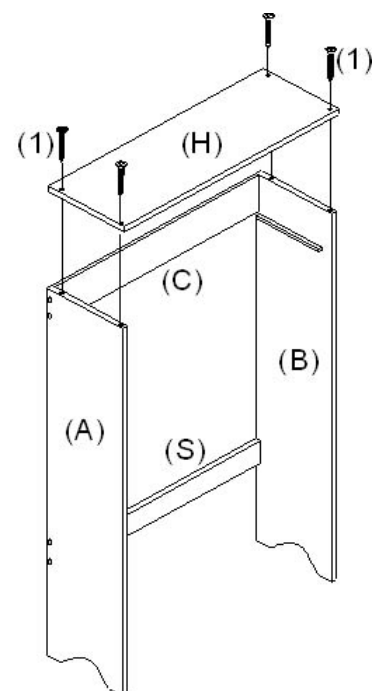

6. TIGHTEN FOUR CAM-BOLTS (3) INTO PRETHREADED HOLES ON UPSIDE OF BOTTOM PANEL (H). NOW USING BOTH HANDS, PLACE ASSEMBLED (G) (E) (F) & (D) ON TOP OF BOTTOM PANEL (H) AND FIT INTO CORRESPONDING HOLES ON UPSIDE OF BOTTOM PANEL (H). INSERT FOUR METAL HINGES (6) INTO SMALL HOLES IN FRONT OF BOTTOM PANEL (H) AND BOTTOM SIDE OF FRONT CROSS BRACE (E). PLACE LEFT DOOR (J) ONTO METAL HINGE (6) ON BOTTOM SIDE OF FRONT CROSS BRACE (E) AND SLIGHTLY LIFT LEFT UPPER SIDE PANEL (G) UP TO FIT BOTTOM OF LEFT DOOR (J) ONTO METAL HINGE (6) ON BOTTOM PANEL (H). INSERT CAM-LOCKS (4) INTO BIG HOLES ON SIDE OF LEFT UPPER SIDE PANELS (G) WITH SLOT FOR SCREWDRIVER FACING

OUTWARD. ROTATE CAM-LOCKS (4) CLOCKWISE TO SECURE CAM-BOLTS (3). PUSH COVERS (5) INTO CAM-LOCKS (4). REPEAT SAME PROCEDURE FOR ATTACHING RIGHT DOOR (R) TO RIGHT UPPER SIDE PANEL (D). (AS SHOWN IN FIGURE 4 )

7. INSERT MACHINE SCREWS ( $\text{Ø}5/32''\times3/4''$ ) (7) THROUGH BACK OF LEFT AND RIGHT DOORS (J, R) AND TIGHTEN INTO KNOBS (8). (AS SHOWN IN FIGURE 4 )

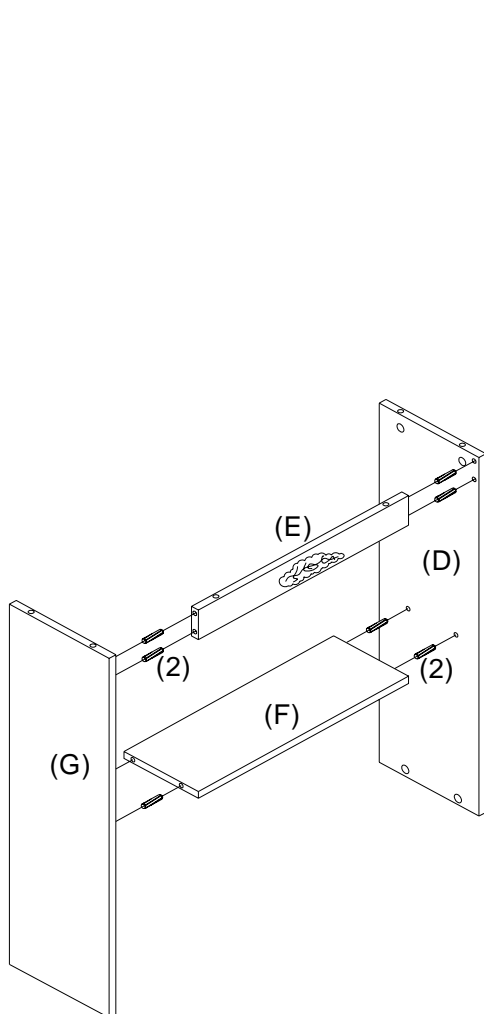

**FIGURE 3**

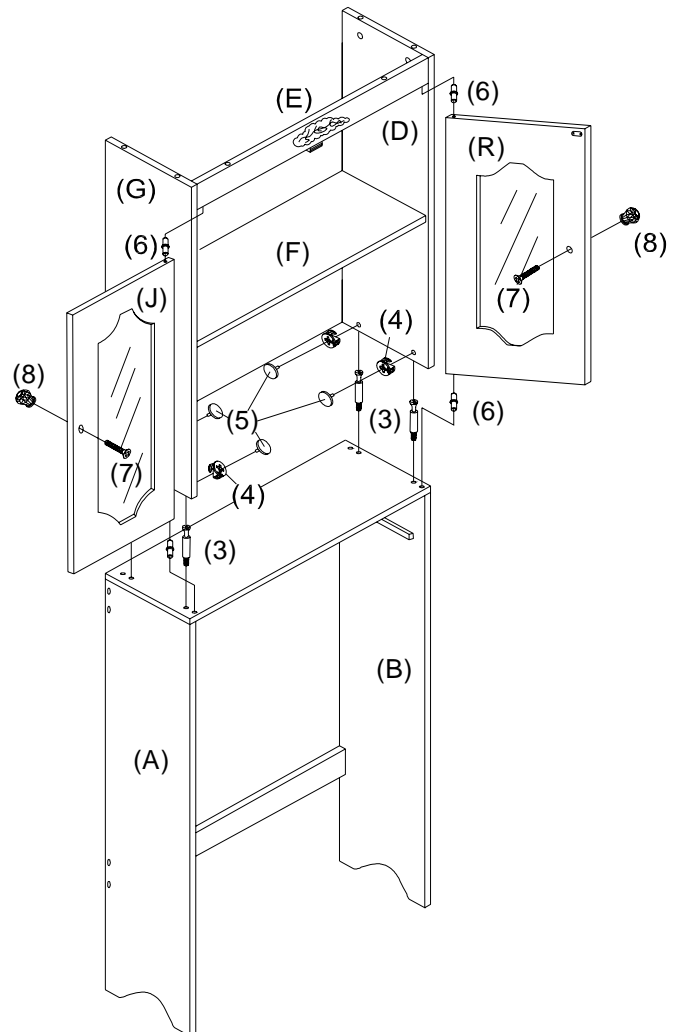

**FIGURE 4**

8. INSERT WOOD DOWEL (2) AND CAM-BOLTS (3) INTO PREDRILLED HOLES ON UNDERSIDE OF TOP PANEL (I) AND FIT INTO CORRESPONDING HOLES ON TOP EDGES OF FRONT CROSS BRACE (E) AND LEFT AND RIGHT UPPER SIDE PANELS (G, D). INSERT CAM-LOCKS (4) INTO BIG HOLES ON INSIDE OF LEFT AND RIGHT UPPER SIDE PANELS (G, D) WITH SLOT FOR SCREWDRIVER FACING OUTWARD. ROTATE CAM-LOCKS (4) CLOCKWISE TO SECURE CAM-BOLTS (3). PUSH COVERS (5) INTO CAM-LOCKS (4). (AS SHOWN IN FIGURE 5).
9. INSERT PAN HEAD WOOD SCREWS ( $\text{Ø}2.6\times10\text{mm}$ ) (9) THROUGH PREDRILLED HOLES ON UPPER AND LOWER BACK PANELS (L, M) AND TIGHTEN INTO CORRESPONDING HOLES ON REAR EDGES OF PARTS (I, G, D, F, H). (AS SHOWN IN FIGURE 6)
10. INSERT MACHINE SCREW ( $\text{Ø}5/32''\times3/4''$ ) (7) THROUGH BACK OF DRAWER FRONT PANEL (O) AND TIGHTEN INTO KNOBS (8). INSERT SMALL FLAT HEAD WOOD SCREWS ( $\text{Ø}3\times18\text{mm}$ ) (10) THROUGH PREDRILLED HOLES ON OUTSIDE OF DRAWER RIGHT PANEL (P) AND TIGHTEN INTO PREDRILLED HOLES ON ENDS OF DRAWER FRONT PANEL (O) AND DRAWER BACK PANEL (Q). SLIDE DRAWER BOTTOM PANEL (K) INTO GROOVES ON DRAWER FRONT PANEL (O) AND

DRAWER BACK PANEL (Q) AND ALIGN WITH GROOVE ON DRAWER RIGHT PANEL (P). ASSEMBLE DRAWER LEFT PANEL (N) IN SAME MANNER. (AS SHOWN IN FIGURE 7)

11. PLACE THE ASSEMBLED DRAWER INTO THE SPACE OF THE UNIT, AND **TIGHTEN METAL DRAWER STOPPER (14) INTO THREADED HOLE ON UNDERSIDE OF BOTTOM PANEL (H)**, (AS SHOWN IN FIGURE 8).

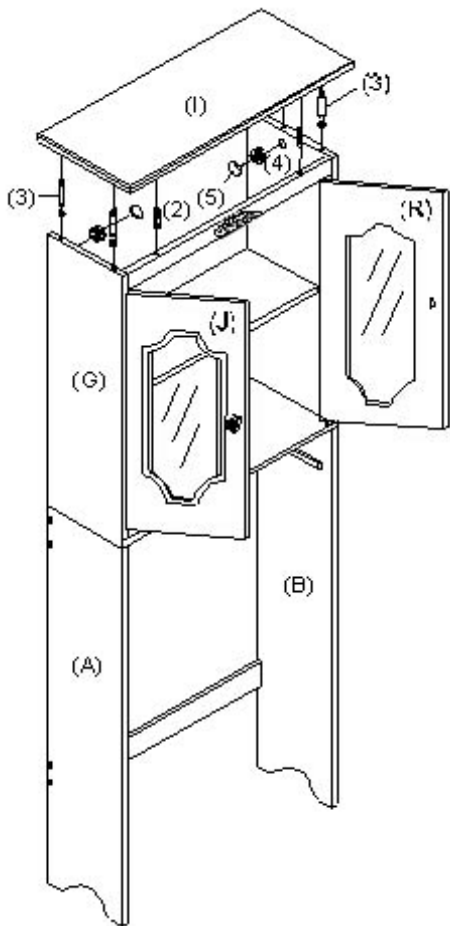

FIGURE 5

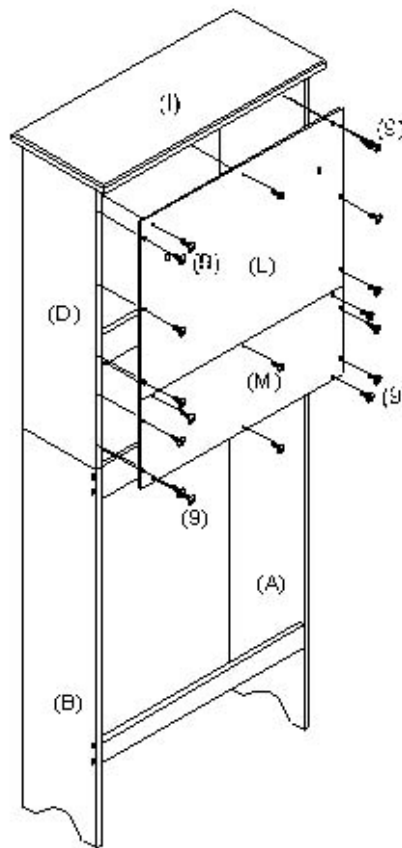

FIGURE 6

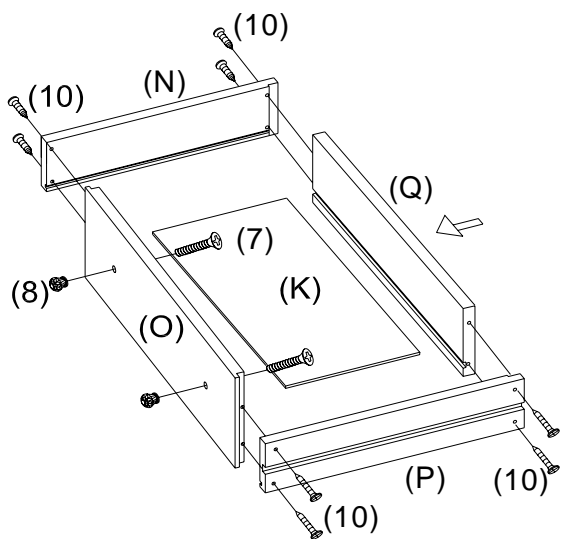

FIGURE 7

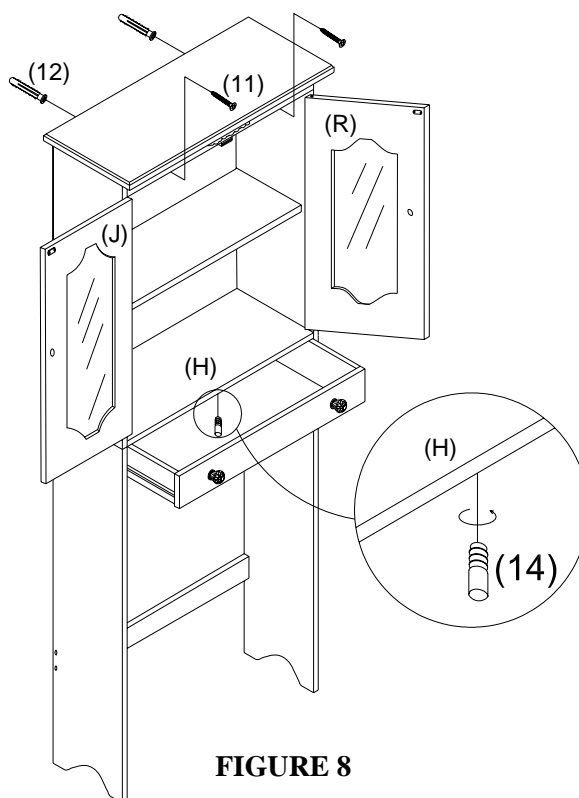

FIGURE 8

12. FOR SAFETY AND STABILITY, PLACE THE UNIT AGAINST WALL, YOU SHOULD DRILL TWO 1/4" DIAMETER HOLES ON WALL, THE DISTANCE BETWEEN TWO HOLES SHOULD MATCH TO THE PREDRILLED HOLES ON UPPER BACK PANEL (L). FIT PLASTIC ANCHORS (12) INTO THE HOLES ON WALL. USE SCREWDRIVER TO SCREW LARGE FLAT HEAD WOOD SCREWS (Ø4X38mm) (11) THROUGH PREDRILLED HOLES ON UPPER BACK PANEL (L) INTO PLASTIC ANCHORS (12). (AS SHOWN FIGURE 8)

**YOUR NEW WHITE MARIETTA SPACESAVER IS FINISHED AND READY TO USE.**

Please count, identify and compare parts and hardware list to be sure all parts are present. It may help to divide parts and label them to correspond with part list. Extra hardware may be included. If any items are missing, please contact our parts/service department at (800) 633-5096 or in Dallas (972) 869-0111/ 9am – 4pm Mon-Fri Central time. Missing or damaged hardware and/ or parts will be replaced free of charge. WE DO NOT SELL PARTS. WE DO NOT RECOMMEND MODIFYING PRODUCT(S) AND WE ARE NOT RESPONSIBLE FOR ANY DAMAGES DUE TO PRODUCT MODIFICATION(S). If this product has not been purchased from our retail affiliates (within 9 months), we are under no obligation to provide parts or replacement merchandise. Parts will not be available for items arrived fully assembled.

**"We will ship parts if available" "This is not a warranty"**

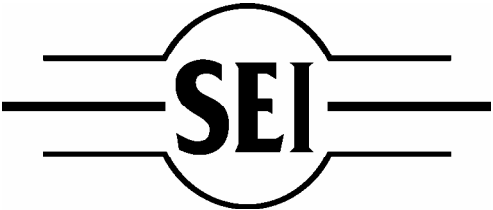
<b>PARTS REPLACEMENT FORM</b>			
JCP LOT# <b>794-5006</b> STYLE NO: <b>BE6841</b>			
Customer Name	PARTS LETTER	PART DESCRIPTION	QUANTITY NEEDED
Street, City, State, Zip			
Phone#			
	<p style="margin: 0;">Please indicate where you purchased this item. Store/website/catalog</p> <p style="margin: 0; text-align: center;">_____ / _____ / _____</p>		
SOUTHERN ENTERPRISES INC. P.O. Box 59996 Dallas, Texas 75229	<p style="margin: 0;">Please indicate color/size/style number</p> <p style="margin: 0; text-align: center;">_____ / _____ / _____</p>		

**NOTE: PLEASE DO NOT OVERTIGHTEN CAMLOCKS!**