







SOUTHERN ENTERPRISES INC.

RELAX...If you can follow a few easy, step-by-step directions in order .YOU CAN ASSEMBLE THIS ITEM.

STYLE NO: **BE6623**

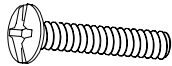
**WHITE ARCH-TOP
HAMPER CABINET**

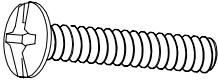
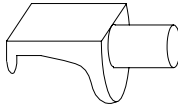
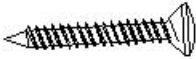
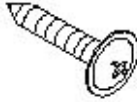
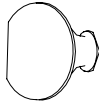
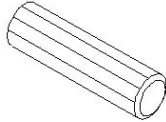
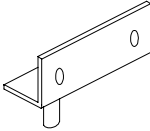
PLEASE FIND HARDWARE IN RED POLYBAG BEFORE DISCARDING PACKING MATERIAL.

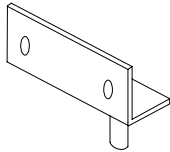
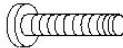
HARDWARE LIST	
<p>(1) MEDIUM MACHINE SCREWS (Ø1/4"X1") 4PCS</p> 	<p>(8) METAL HINGES 2PCS</p> 
<p>(2) LARGE MACHINE SCREWS 8PCS (Ø1/4"X1-1/2")</p> 	<p>(9) SHELF SUPPORTS 4PCS</p> 
<p>(3) LARGE FLAT HEAD WOOD SCREWS(Ø3X18mm) 8PCS</p> 	<p>(10) PAN HEAD WOOD SCREWS(Ø2.6X10mm) 18PCS</p> 
<p>(4) METAL KNOBS 3PCS</p> 	<p>(11) WOOD DOWELS 8PCS</p> 
<p>(5) RIGHT METAL HINGE 1PC</p> 	<p>(12) PLASTIC PLUGS 12PCS</p> 
<p>(6) LEFT METAL HINGE 1PC</p> 	<p>(13) SMALL MACHINE SCREWS (Ø5/32"X5/8") 3PCS</p> 

PARTS LIST

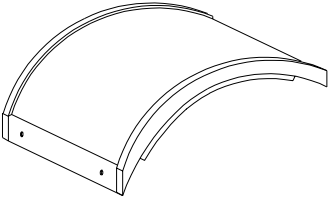
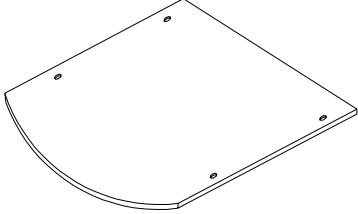
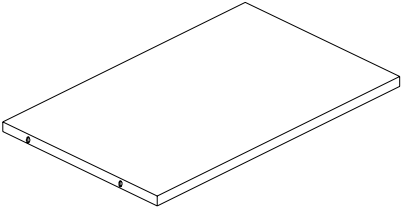
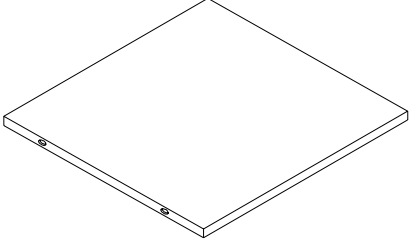
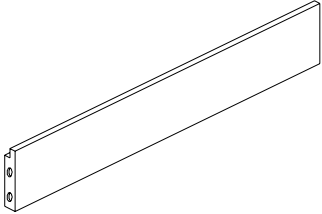
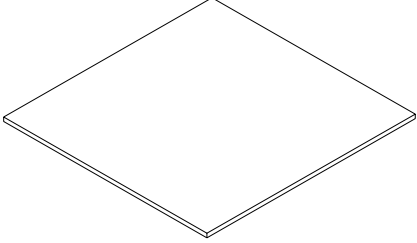
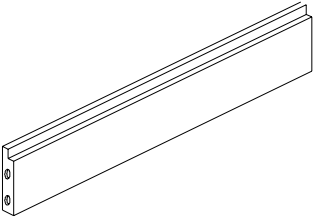
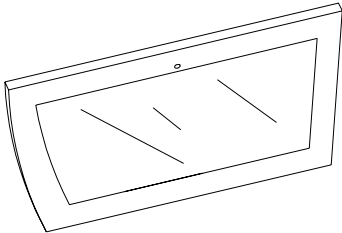
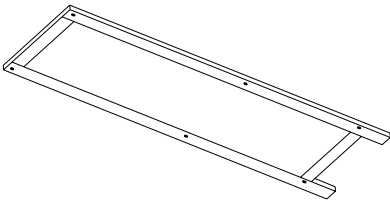
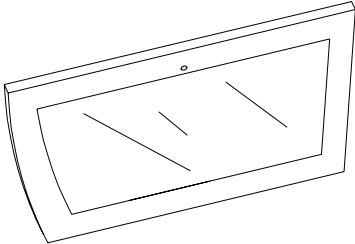
<p>(A) TOP PANEL</p> <p align="right">1PC</p> 	<p>(I) HAMPER LEFT SIDE PANEL</p> <p align="right">1PC</p> 
<p>(B) FIXED SHELF</p> <p align="right">1PC</p> 	<p>(J) HAMPER BACK PANEL</p> <p align="right">1PC</p> 
<p>(C) FRONT CROSS BRACE</p> <p align="right">1PC</p> 	<p>(K) HAMPER BOTTOM PANEL</p> <p align="right">1PC</p> 
<p>(D) BACK CROSS BRACE</p> <p align="right">1PC</p> 	<p>(L) RIGHT DOOR</p> <p align="right">1PC</p> 
<p>(E) LEFT SIDE PANEL</p> <p align="right">1PC</p> 	<p>(M) LEFT DOOR</p> <p align="right">1PC</p> 

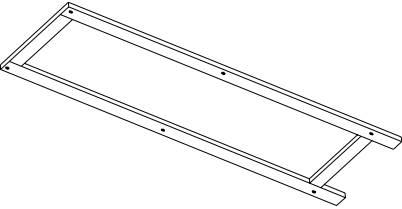
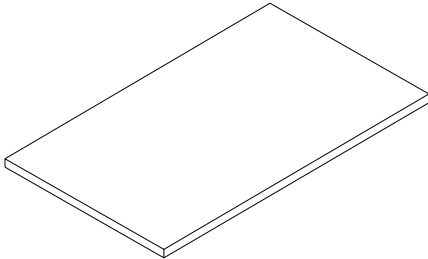
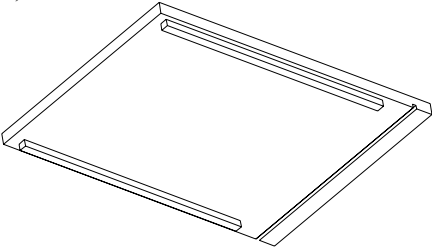
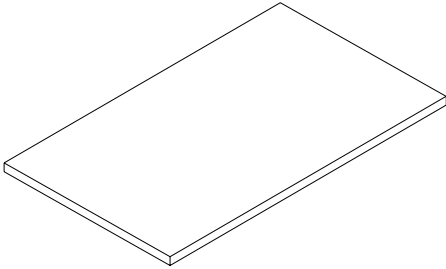
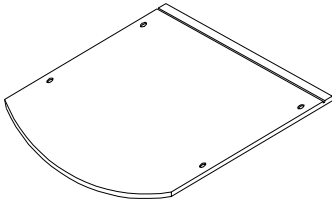
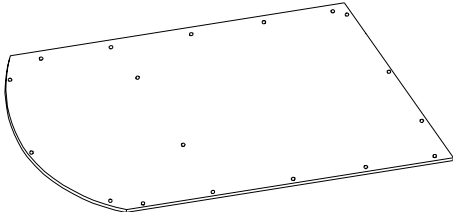
<p>(F) RIGHT SIDE PANEL 1PC</p> 	<p>(N) ADJUSTABLE SHELF 1PC</p> 
<p>(G) HAMPER FRONT PANEL 1PC</p> 	<p>(O) BOTTOM PANEL 1PC</p> 
<p>(H) HAMPER RIGHT SIDE PANEL 1PC</p> 	<p>(P) BACK PANEL 1PC</p> 

ASSEMBLY INSTRUCTIONS

1. SELECT A SMOOTH, SOFT SURFACE TO PREVENT SCRATCHING FINISH.
2. YOU MAY NEED A PHILLIPS SCREWDRIVER.
3. INSERT LARGE FLAT HEAD WOOD SCREWS ($\varnothing 3 \times 18 \text{mm}$) (3) THROUGH PREDRILLED HOLES ON OUTSIDE OF HAMPER LEFT SIDE PANEL (I) AND TIGHTEN INTO PREDRILLED HOLES ON ENDS OF HAMPER FRONT PANEL (G) AND HAMPER BACK PANEL (J). SLIDE HAMPER BOTTOM PANEL (K) INTO GROOVES ON HAMPER FRONT PANEL (G) AND HAMPER BACK PANEL (J) AND ALIGN WITH GROOVE ON HAMPER LEFT SIDE PANEL (I). ASSEMBLE HAMPER RIGHT SIDE PANEL (H) IN SAME MANNER. INSERT SMALL MACHINE SCREWS ($\varnothing 5/32'' \times 5/8''$) (13) THROUGH PREDRILLED HOLE ON BACK OF HAMPER FRONT PANEL (G) AND TIGHTEN INTO METAL KNOB (4). (AS SHOWN IN FIGURE 1)

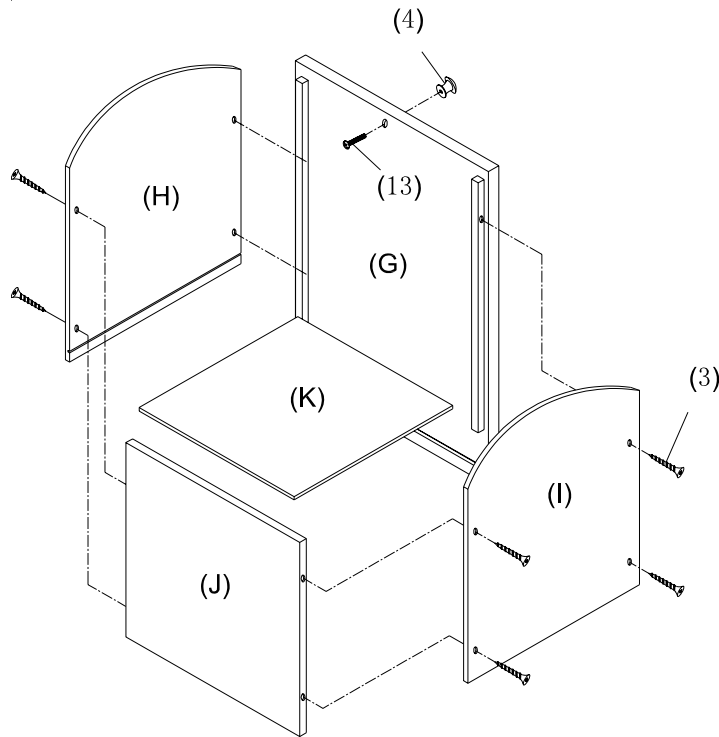

FIGURE 1

4. INSERT WOOD DOWELS (11) INTO PREDRILLED HOLES ON ENDS OF FIXED SHELF (B), FRONT AND BACK CROSS BRACE (C, D) AND FIT INTO CORRESPONDING HOLES ON INSIDE OF LEFT SIDE PANEL (E). INSERT T-BOLTS (14) INTO PREDRILLED HOLES ON UNDERSIDE OF FIXED SHELF (B), FRONT AND BACK CROSS BRACE (C, D). INSERT LARGE MACHINE SCREWS ($\text{\O}1/4''\times1-1/2''$) (2) THROUGH PREDRILLED HOLES ON OUTSIDE OF LEFT SIDE PANEL (E) AND TIGHTEN INTO T-BOLTS (14). PLEASE NOTE THAT IF SCREWS DO NOT TIGHTEN, ROTATE T-BOLTS (14) SO THAT THE THREADS OF T-BOLTS (14) ARE FACING SCREWS. TIGHTEN MEDIUM MACHINE SCREWS ($\text{\O}1/4''\times1''$) (1) THROUGH PREDRILLED HOLES ON OUTSIDE OF LEFT SIDE PANEL (E) INTO CORRESPONDING HOLES ON END OF TOP PANEL (A). PUSH PLASTIC PLUGS (12) INTO HOLES ON OUTSIDE OF LEFT SIDE PANEL (E) (AS SHOWN IN FIGURE 2)
5. SLIDE BOTTOM PANEL (O) INTO THE GROOVES ON FRONT AND BACK CROSS BRACE (C, D) AND ALIGN WITH LEFT SIDE PANEL (E). PLACE ASSEMBLED HAMPER CABINET INTO THE SPACE OF BETWEEN OF FIXED SHELF (B) AND FRONT AND BACK CROSS BRACE (C, D), FIT THE METAL TAGS OF HAMPER CABINET INTO PREDRILLED HOLES ON INSIDE OF LEFT SIDE PANEL (E). (AS SHOWN IN FIGURE 2)

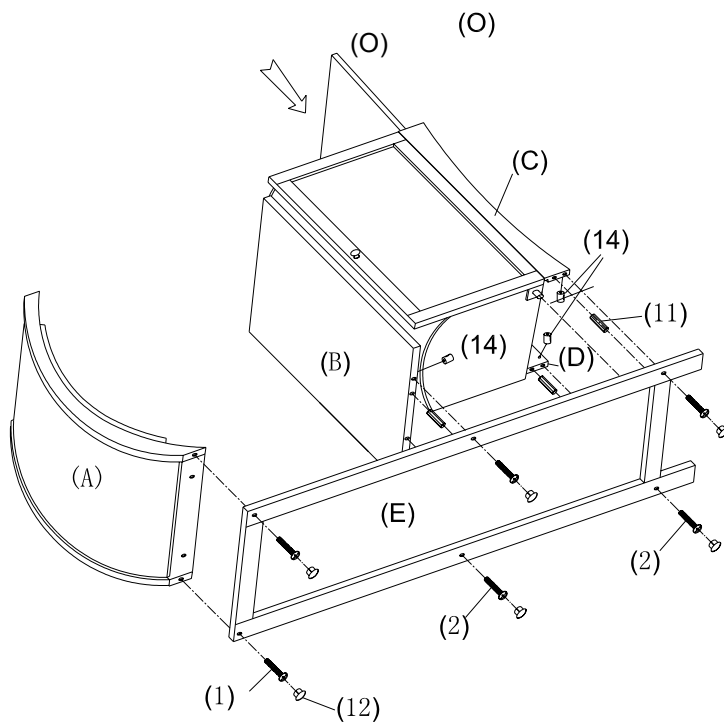

FIGURE 2

6. REPEAT STEP 4 TO ASSEMBLE RIGHT SIDE PANEL (F). (AS SHOWN IN FIGURE 3)
7. INSERT METAL HINGES (8) INTO PREDRILLED HOLES ON TOP EDGES OF LEFT AND RIGHT DOORS (M, L) AND FIT INTO CORRESPONDING HOLES ON UNDERSIDE OF TOP PANEL (A). INSERT LEFT AND RIGHT METAL HINGES (5, 6) INTO PREDRILLED HOLES ON UPSIDE OF FIXED SHELF (B). INSERT SMALL FLAT HEAD WOOD SCREWS (Ø3X10mm) (7) THROUGH LEFT AND RIGHT METAL HINGES (6, 5) AND TIGHTEN INTO PREDRILLED HOLES ON LEFT AND RIGHT DOORS (M, L) . INSERT SMALL MACHINE SCREWS (Ø5/32”X5/8”) (13) THROUGH PREDRILLED HOLES ON LEFT AND RIGHT DOORS (M, L) AND TIGHTEN INTO METAL KNOBS (4). (AS SHOWN IN FIGURE 4)
8. FIT SHELF SUPPORTS (9) INTO PREDRILLED HOLES ON LEFT AND RIGHT SIDE PANELS (E, F). PUT ADJUSTABLE SHELF (N) ON SHELF SUPPORTS (9). (AS SHOWN IN FIGURE 4)
9. ATTACH BACK PANEL (P) INTO SLOTS ON PARTS (A, E, F, O). INSERT PAN HEAD WOOD SCREWS (Ø2.6X10mm) (10) THROUGH PREDRILLED HOLES ON BACK PANEL (P) AND TIGHTEN INTO CORRESPONDING HOLES ON REAR EDGES OF PARTS (A, B, E, F, O). (AS SHOWN IN FIGURE 5)

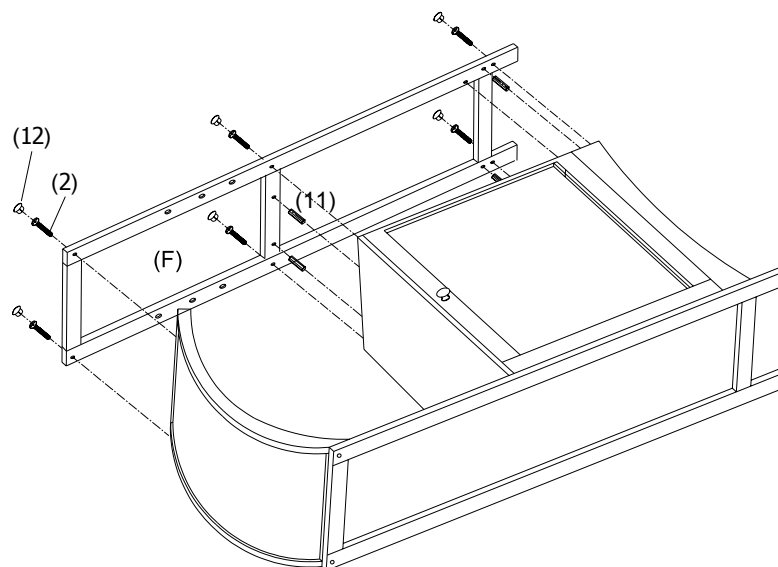

FIGURE 3

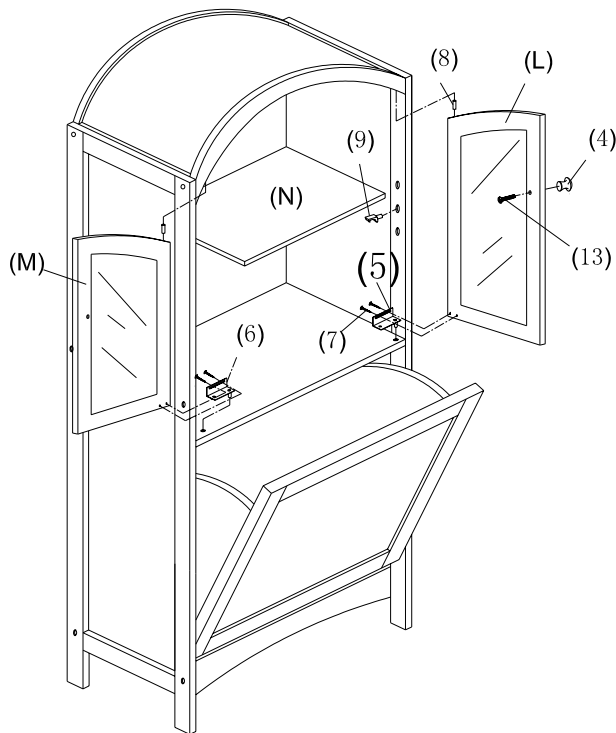

FIGURE 4

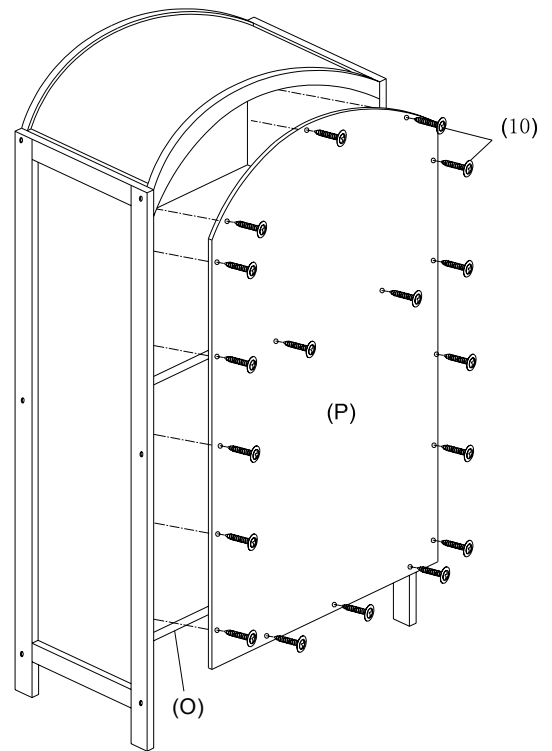

FIGURE 5

YOUR NEW WHITE ARCH-TOP HAMPER CABINET IS FINISHED AND READY TO USE.

Please count, identify and compare parts and hardware list to be sure all parts are present. It may help to divide parts and label them to correspond with part list. Extra hardware may be included. If any items are missing, please contact our parts/service department at (800) 633-5096 or in Dallas (972) 869-0111/ 9am – 4pm Mon-Fri Central time. Missing or damaged hardware and/ or parts will be replaced free of charge. WE DO NOT SELL PARTS. WE DO NOT RECOMMEND MODIFYING PRODUCT(S) AND WE ARE NOT RESPONSIBLE FOR ANY DAMAGES DUE TO PRODUCT MODIFICATION(S). If this product has not been purchased from our retail affiliates (within 9 months), we are under no obligation to provide parts or replacement merchandise. Parts will not be available for items arriving fully assembled.

PLEASE DO NOT OVERTIGHTEN CAMLOCKS!

PARTS REPLACEMENT FORM

STYLE NO: **BE6623**

Customer Name	PARTS LETTER	PART DESCRIPTION	QUANTITY NEEDED
Street, City, State, Zip			
Phone#			

SOUTHERN ENTERPRISES INC.
P.O. Box 59996 Dallas, Texas 75229

Please indicate where you purchased this item.

Store/website/catalog

/ /

Please indicate color/size/style number

/ /